

Strata[®] ***VI_e***

STRATA VI_e
GENERAL DESCRIPTION
TABLE of CONTENTS

PARAGRAPH	SUBJECT	PAGE
	TABLE of CONTENTS	i
01	GENERAL	1
	Summary Description	1
02	PHYSICAL DESCRIPTIONS	1
	Key Service Unit	1
	Peripheral Equipment	2
	Electronic Key Telephones	2
03	ELECTRICAL CHARACTERISTICS	3
	General	3
04	FEATURES and SERVICES	4
	TABLE A—Summary of Electrical Characteristics	4
	TABLE B—Standard Features	5
	TABLE C—Optional Features	5
05	SYSTEM OPERATION	6
	General	6
06	SYSTEM CONFIGURATION	7
	Key Service Unit	7
	Option Modules	8
	Station Equipment	9
	Installation	10
	Maintenance	10
07	FEATURES and OPERATION	10
	General	10
	Standard Features	10
	System	10
	Station	12
	Optional Features	13

ILLUSTRATION LIST

FIGURE NO.	TITLE	PAGE
1	HKSU (Dimensions)	1
2	HKSU CABINET	1
3	HKSU (Internal View)	1
4	EXTERNAL MODULES	2
5	10-key ELECTRONIC KEY TELEPHONE	2
6	SINGLE-LINE EKT	3
7	10-key BLF EKT	3
8	20-key EKT	3
9	20-key LCD EKT	3
10	SYSTEM DIAGRAM	6
11	FUNCTIONAL BLOCK DIAGRAM	7
12	HKSU (with PCBs)	8
13	DOOR PHONE	9

01 GENERAL

Summary Description

STRATA VI_e is an electronic key telephone system with many standard features; utilizing stored program control, custom LSI circuitry, solid-state, space-division switching and reduced station cabling. Served by a key service unit (HKSU) that is housed in a single cabinet, the system is factory-equipped with three central office/PBX lines, two intercom lines, and eight station lines. The system expands to a maximum capacity of six central office/PBX lines, two intercom lines, and 16 station lines.

The system utilizes specially designed electronic key telephones (EKTs). Each EKT is connected to the system via industry-standard 2-pair cabling, and is equipped with a push-button dial pad. Solid-state electronics within the HKSU translate signals from the station dial pad into either DTMF or rotary-dial signals, as required by the central office.

It is electrically compatible with the public telephone network and is also designed to function in a "behind PBX" environment.

Maintenance procedures are based on quickly locating and replacing defective plug-in units, keeping service disruption to a minimum.

02 PHYSICAL DESCRIPTIONS

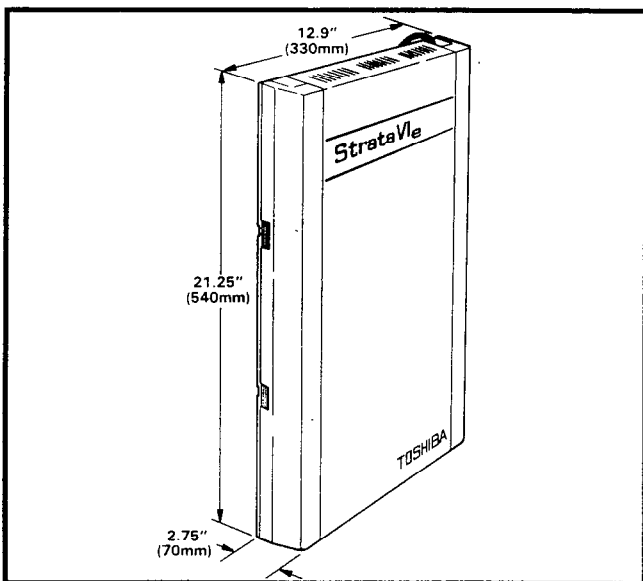

FIGURE 1—HKSU (Dimensions)

Key Service Unit

Designed for wall mounting, the HKSU is housed in a single metal cabinet (Figure 1) with the following dimensions:

Height: 21.25" (540 mm)

Width: 12.9" (330 mm)

Depth: 2.75" (70 mm)

Weight: 15.63 lbs. (7.09 kg)

The cabinet (Figure 2) consists of a base, cover and side covers.

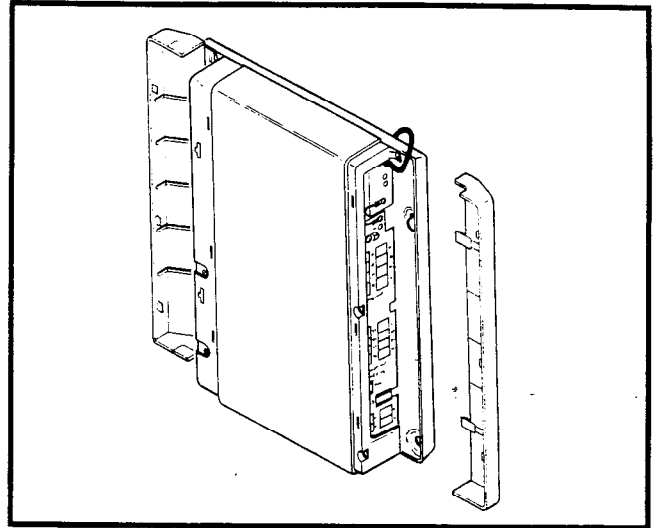

FIGURE 2—HKSU CABINET

The HKSU (see Figure 3 for factory-equipped HKSU) will accommodate up to seven printed circuit boards (PCBs). The various dimensions and designations of these PCBs are:

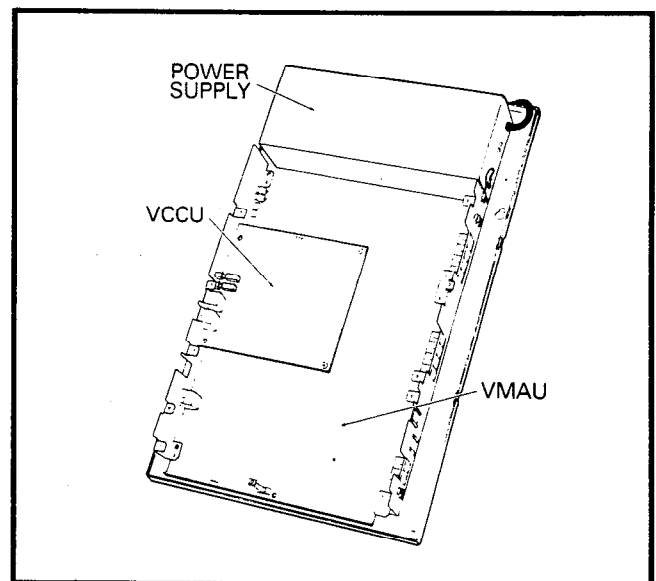

FIGURE 3—HKSU (Internal View)

STRATA VI_e
GENERAL DESCRIPTION
NOVEMBER 1986

- VMAU: 9.75 x 15.37"
(248 x 390 mm)
- VCOU: 5.75 x 10.60"
(146 x 269 mm)
- VCCU: 6.00 x 6.50"
(152 x 165 mm)
- SSTU: 4.13 x 4.60"
(105 x 117 mm)
- SEPU: 4.25 x 3.00"
(108 x 76 mm)
- SMOU: 2.25 x 1.13"
(57 x 29 mm)

The VMAU PCB is secured directly to the base of the cabinet; the remaining PCBs attach to the VMAU.

Peripheral Equipment

Four optional expansion modules are available to accommodate the Door Phone (HDCB), Off-Premises Line (HOLB), Station Message Detail Recording (HSMB) and Off-Premises Extension (HOXB) features. The two pairs of modules are identical in external appearance (Figure 4). A door phone (MDFB) is also available. An external ring generator/power

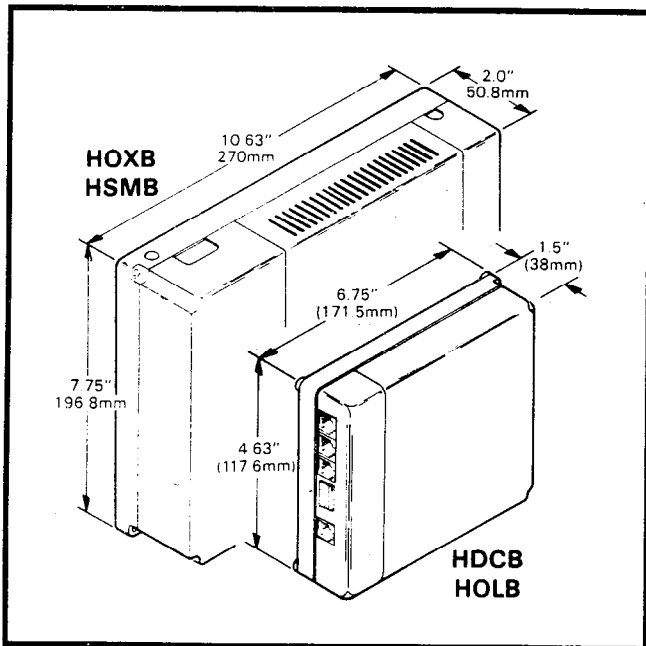

FIGURE 4—EXTERNAL MODULES

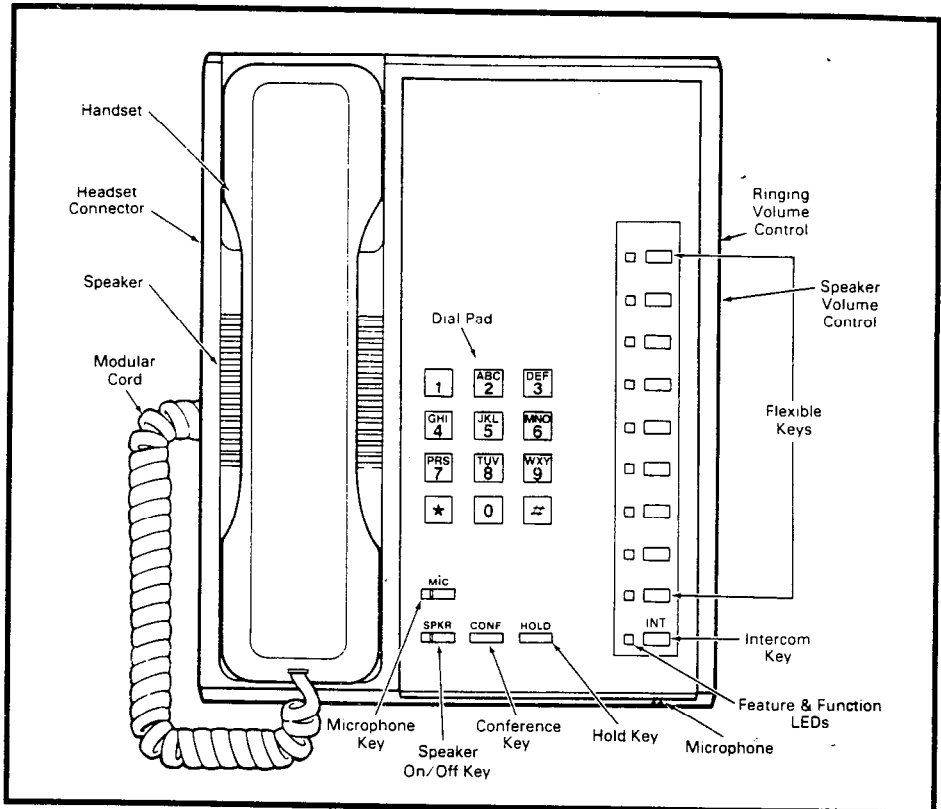

FIGURE 5—10-key ELECTRONIC KEY TELEPHONE

supply (MRGU) that can be used with the HOXB is also provided.

Electronic Key Telephones

Seven different electronic key telephones (EKTs) may be used in STRATA VI_e:

- 1) 10-key EKT (Figure 5): Available in two models, as a speakerphone or with handsfree answerback (HFU) on intercom calls only.
- 2) Single-line EKT (Figure 6): Equipped with three permanently dedicated keys (**HOLD**, **CONF**, **SPKR**) and an intercom/CO line key, which is not labeled.
- 3) 10-key BLF EKT (Figure 7): Available as a speakerphone-only model, with 16 LEDs used as a Busy Lamp Field (BLF).
- 4) 20-key EKT (Figure 8): Also available in two models, speakerphone or HFU.
- 5) 20-key LCD EKT (Figure 9): Available as a speakerphone-only EKT with a 32-character alphanumeric Liquid Crystal Display (12-digit display in current release).



FIGURE 6—SINGLE-LINE EKT



FIGURE 7—10-key BLF EKT



FIGURE 8—20-key EKT



FIGURE 9—20-key LCD EKT

All EKTs have the same dimensions:

Height: 3.6" (92 mm)
Width: 7.0" (178 mm)
Depth: 9.0" (229 mm)

Housed in an impact-resistant, off-white plastic case, each EKT comes with a brown faceplate (with wine, black or blue faceplates available as extra cost options).

System software assignments permit a wide variation to the feature keys on all EKTs.

Each EKT features a modular handset cord, a modular headset connector (except the

single-line EKT) and is connected to the system via a 4-conductor modular line cord. All EKTs are easily wall-mounted and are hearing-aid compatible.

03 ELECTRICAL CHARACTERISTICS

General

The HKSU operates from an internal power supply, which connects to a nominal 117 VAC, grounded wall outlet.

Loss of AC power will cause operational failure of the system. System memory, however, is protected from loss due to power

STRATA VI_e
GENERAL DESCRIPTION
NOVEMBER 1986

failure with a memory backup battery. In addition, full system reserve power is available as an option.

NOTE:

The batteries used are designed to maintain full memory protection for up to five years with no external power source applied.

The electrical characteristics of the system are detailed in Table A.

04 FEATURES and SERVICES

The features and services of this electronic key telephone system are summarized in Tables B and C, which list the standard and optional features, respectively.

TABLE A

SUMMARY OF ELECTRICAL CHARACTERISTICS

Loop Limits	
Station	1,000' (305 M), 24 AWG cable
Door Phone Control Unit (HDCB)	1,000' (305 M), 24 AWG cable
Door Phone/Monitor Station	1,000' (305 M), 24 AWG cable
HOLB, HOXB, HSMB	17', (5.2 M), 24 AWG cable
Ringling Tones	
CO Line (idle EKT)	600/800 Hz, modulated by 16 Hz, 1 second on—3 seconds off
CO Line (busy EKT)	2,400 Hz, modulated by 10 Hz, 1 second on—3 seconds off
Intercom Line	600 Hz, 1 second on—3 seconds off
Door Phone A & C Tones	870 Hz, 1 second/710 Hz, 2 1/2 seconds (5 rings)
Door Phone B Tone	870 Hz, 1/2-second/710 Hz, 2 1/2 seconds (5 rings)
Busy Override Tone	2,400 Hz, 1 second on—3 seconds off
Dial Tone (Intercom)	400 Hz, continuous
Ringback Tone	400 Hz, 1 second on—3 seconds off
Busy Tone	400 Hz, 1/4-second on—1/4-second off
Do Not Disturb Tone	400 Hz, 1/8-second on—1/8-second off
Voice Page Warning Tone	600 Hz, 1 second on only (via EKT speaker)
Executive Override Warning Tone	600 Hz, 1/2-second on only (via handset)
Hold Recall Tone	2,400 Hz, modulated by 10 Hz, 1 second on—1 second off
Dialing	Push-button; system-generated DTMF or dial pulse
Primary Power	117 VAC, 60 Hz
HPSU 7120	100 watts
Environmental Specifications	
Operating Temperature	32 - 22° F (0 - 50° C)
Operating Humidity	20 - 80% relative humidity, without condensation

TABLE B
STANDARD FEATURES

SYSTEM

- All Call Voice Page
- Automatic Dialing-System
- Automatic Hold Recall
- Automatic Release from Hold
- CO Call Pickup
- Conference (Multi-Station)*
- Conference (Multi-CO Line)*
- Distinctive Ringing
- DTMF and Dial Pulse CO Line Compatible
- External Page Interface
- Flexible Key Assignment
- Flexible Line Ringing Assignment
- Forced Account Code
- Group Paging
- Live System Programming
- Message Waiting
- MF Signal Time (160/80 ms)
- Multiple Simultaneous Handsfree Intercom Paths
- Music-On-Hold Interface
- Night Ring Answer Code
- Night Ringing Over External Page
- Night Transfer
- Non-blocking Dialing
- Outgoing Call Restriction
- PBX Compatible
- Privacy/Non-Privacy
- Private CO Lines
- Relay Service
- Toll Restriction (6-digit)
- Toll Restriction Override by System Automatic Dialing
- Voice or Tone Signalling
- Wall Mountable HKSU

**Non-amplified*

STATION

- Automatic Callback (Intercom)
- Automatic Dialing-Station
- Automatic Off-Hook Selection
- Busy Override
- Call Forward
- Call Pickup
- Call Transfer with Camp-on
- Directed Call Pickup
- Direct Station Selection (DSS) Keys
- Do Not Disturb
- Do Not Disturb Override
- DP/MF Mode Change (TONE Key)
- Exclusive Hold
- Executive Override (Break-In)
- Flash Key (PBX Transfer or CO Dial Tone Recall)
- Handsfree Answerback
- I-called Illumination
- I-hold Illumination
- I-use Illumination
- Modular Handset and Line Cords
- On-Hook Dialing
- Push-Button Dialing
- Repeat Last Number Dialed
- Ringing Line Preference
- Saved Number Redial
- Station Security (MCO Key)
- Station-to-Station Message Waiting with LCD
- Trunk Queuing

TABLE C

OPTIONAL FEATURES

- Background Music with Station Control
- Door Phone/Monitor Station
 - Alarm Key
 - Door Lock Key
- EKT Faceplates (Blue, Black or Wine)
- External Page Amplifier
- Music-On-Hold Source
- Off-Premises Extension
 - Ring Generator/Power Supply (MRGU)
- Off-Premises Line
- Station Message Detail Recording (SMDR)
- System Battery Backup
- Single-Line EKT
- 10-key EKT (HFU or Speakerphone)
- 10-key Busy Lamp Field (BLF) EKT
- 20-key EKT (HFU or Speakerphone)
- 20-key Liquid Crystal Display (LCD) EKT

05 SYSTEM OPERATION

General

The system (Figure 10) consists of an HKSU, power supply and up to 16 electronic key telephones (EKTs), up to three door phones (the door phone control unit occupies one station), and optional modules (HOLB, HOXB and HSMB). All connections between

the HKSU and the EKTs are made via a customer-provided main distribution frame (MDF). Using modular line cord(s), the CO lines are then connected between the left side panel and the locally provided RJ-25C (up to two each) or RJ-11C (up to six each) jacks. An external tuner (or equivalent) is required if the Music-On-Hold/Background Music feature is utilized.

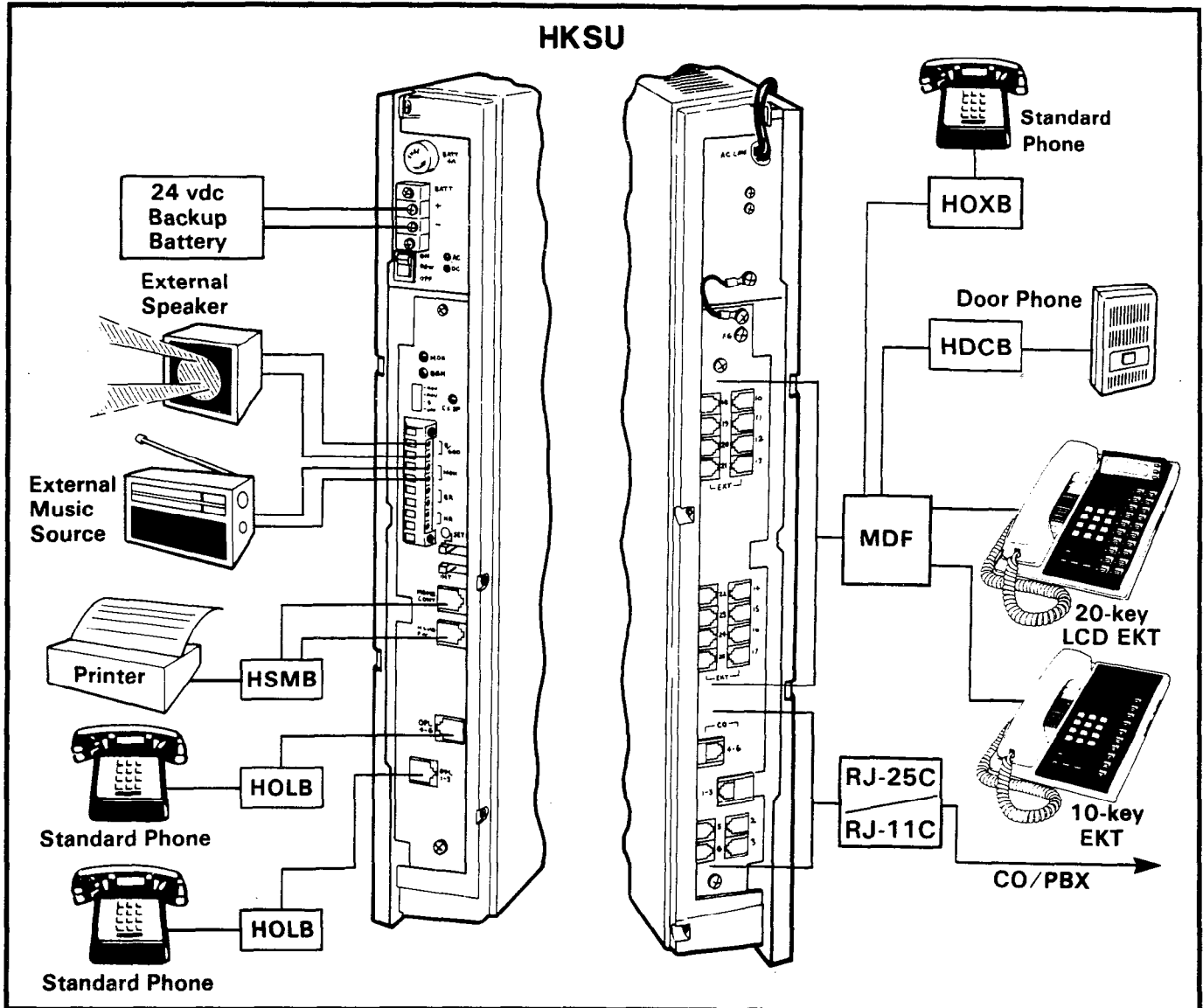

FIGURE 10—SYSTEM DIAGRAM

A functional block diagram of the HKSU is shown in Figure 11. It consists of CO and station interfaces on the VMAU, including a solid-state, space-division matrix and the central control equipment (VCCU). Optional interfacing equipment includes additional sta-

tion connections (SSTU), additional CO connections (VCOU), Off-Premises Line (HOLB), Off-Premises Extension (HOXB) as well as the ring generator/power supply (MRGU) and the Station Message Detail Recording (HSMB).

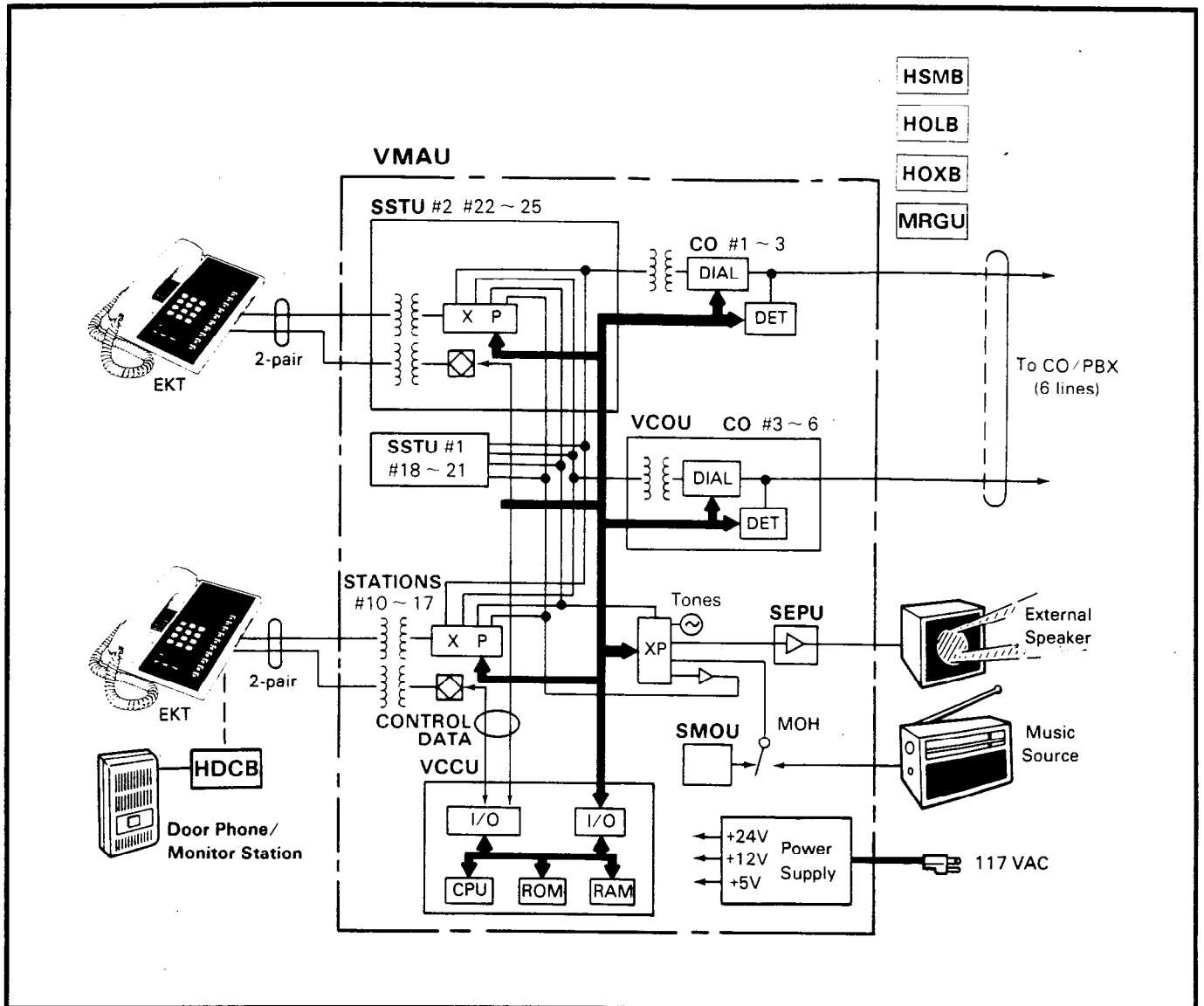

FIGURE 11—FUNCTIONAL BLOCK DIAGRAM

Connections between the station voice lines and the CO lines are via the switching matrix provided on the VMAU PCB.

The system is entirely under the control of a single-chip microprocessor, located (along with the system program and data memories) on the VCCU PCB.

06 SYSTEM CONFIGURATION

Key Service Unit

The HKSU arrangement illustrated in Figure 12 shows the locations of the various PCBs and optional equipment. The optional modules are used only when required. All

PCBs connect to the VMAU (in some cases, they also attach to the HKSU's side panel).

Complete with all available options, the HKSU utilizes up to seven different printed circuit boards internally (as shown in Figure 12) and various option modules. The functions of the internal units and power supply are:

VMAU: The main PCB of the HKSU consists of the following three functions:

- a) **Station Interface**—An interface between the HKSU and up to eight EKTs, which includes the solid-state, space-division matrix used for voice connections be-

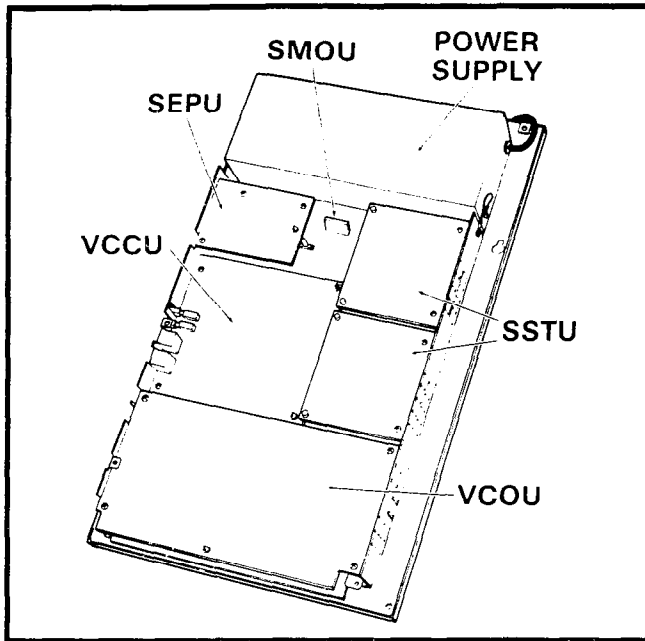

FIGURE 12—HKSU (with PCBs)

tween the EKTs and the CO/PBX lines. Two-pair wiring is required for each EKT; one pair carrying voice and the other pair carrying data to and from the EKT.

b) **CO Interface**—An interface between the HKSU and the public telephone network or PBX for three lines. Ring detection, hold and dial outpulsing for three lines are performed by this PCB. Depending upon local CO requirements, the VMAU is programmed to provide DTMF or rotary-dial outpulsing.

c) **Tone**—Performs a number of miscellaneous system functions:

- Generates system tones.
- Provides the switching matrix for the delivery of tones for both paging and intercom connections.
- Houses the interface for the external page.
- Houses the interface for music-on-hold.

VCOU: An optional interface between the VMAU and three additional public telephone network or PBX lines. Depending upon local CO requirements, the VCOU is programmed to provide DTMF or rotary-dial outpulsing. The VCOU PCB serves up to three CO/PBX lines and three OPLs.

SSTU: An optional interface between the HKSU and stations 18 - 25. Each SSTU PCB serves up to four EKTs. Two-pair wiring is required for each EKT; one pair carrying voice and the other pair carrying control data to and from the EKT.

VCCU: All system control functions are performed by the single-chip microprocessor on this PCB. The system program stored in ROM, the RAM for system operations, and the RAM for system data storage are also located on this circuit board. A battery on this PCB protects system memory should a power failure occur.

SMOU: The SMOU is an optional music-on-hold source that provides electronic synthesized music. One of two musical tunes are available, selected via a switch on this PCB. The SMOU is connected to the VMAU via a 7-pin connector.

SEPU: An optional 3-watt amplifier for external paging, using a customer-supplied 8-ohm speaker (connected to the VMAU via a 10-pin connector).

HPSU 7120: The system's required voltages are provided by this factory-installed power supply. The HPSU requires 117 VAC, 60 Hz, with a permissible AC input voltage range of 90 - 130 VAC.

HPBU-7: An optional battery backup unit. It is a PCB that mounts inside the power supply housing and is connected to the recommended battery pack (which is customer-supplied, consisting of two 12 VDC, maintenance-free, automobile-type batteries—80 amp/hour maximum rating). With the optional battery backup assembly installed, all functions of the system will continue to operate for several hours (the actual time period is in direct ratio to the type and size of batteries selected) after a loss of normal electrical power. No calls will be disconnected during switch-over to or from battery power.

Option Modules

HOLB: An off-premises line module that allows the bridging of a CO/PBX line, which appears in the system with a conventional telephone; supervision is provided. Each HOLB provides three circuits, all three of which may be directed to an answering

machine (or similar device) attached to the HUNT connector.

HOXB: An external module that serves as an interface between the HKSU and conventional, single-line telephones or off-premises extension (OPX) lines. Each HOXB PCB serves two extensions; one HOXB per system. An HOXB will operate with either DTMF or rotary-dial telephones. An auxiliary ring generator/power supply (MRGU) is required for the HOXB.

HSMB: Serves as an interface between the HKSU and a printer or storage device used for the SMDR feature. The module is equipped with an RS-232C interface and connects to the left side panel via two supplied 8-wire modular connectors (one HSMB per system).

HDCB: An optional module connected to the HKSU at EKT 13 or 14 that allows up to three door phone/monitor stations (MDFBs) to ring pre-selected EKTs. The HDCB has three outputs (A, B, C), which are modular connectors for the three MDFBs. (Outputs B and C may be used for the Door Lock and Alarm features, respectively.)

Station Equipment

The principal components of the 10-key electronic key telephone (Figure 5) are: handset, dial pad, handsfree answerback (HFU) microphone, microphone control key (**MIC**), speaker and **SPKR** key, two volume controls, an **INT** key, and nine CO/PBX line or feature keys. LED indicators are provided for all keys except the **HOLD** and **CONF** keys. With the exception of the four permanently dedicated keys and the **INT** key, the remaining feature keys can be assigned to any one of several keystrip modes by programming. (An identical EKT is available as a speakerphone.)

The single-line EKT (Figure 6) has three permanently dedicated keys (**HOLD** **CONF** **SPKR**) and an intercom/CO line key, which is not labeled.

A 10-key BLF EKT (Figure 7) provides the same features as those listed above, plus an LED indication of which stations are in use.

The 20-key EKT (Figure 8) provides the same features as those listed in the above

two paragraphs, and has 10 additional feature keys.

A 20-key Liquid Crystal Display (LCD) EKT (Figure 9), incorporating the same features as those listed above for the 20-key, may be located at any or all of the stations. The 32-character alphanumeric Liquid Crystal Display (12-digit display in current release) provides station-to-station message waiting capabilities. Other features include an accurate clock/calendar in its idle state; and elapsed time, dialed number, calling station and CO line are displayed by the lower line of characters only.

All EKTs are easily converted for wall mounting, feature modular handset cords, are equipped with a second modular connector for headset connection (except the single-line EKT), and are connected to the system via 2-pair modular line cords.

The optional door phone/monitor station (Figure 13) allows a door phone unit to distinctly ring pre-selected station(s). When a station dials an individual door phone, a circuit providing monitoring capabilities on the intercom is established. This option requires station 13 or 14 to be replaced by a door phone control unit (HDCB) and up to three door phone units (MDFBs). One door phone/monitor can be replaced by an alarm control circuit and one by a door lock control circuit.

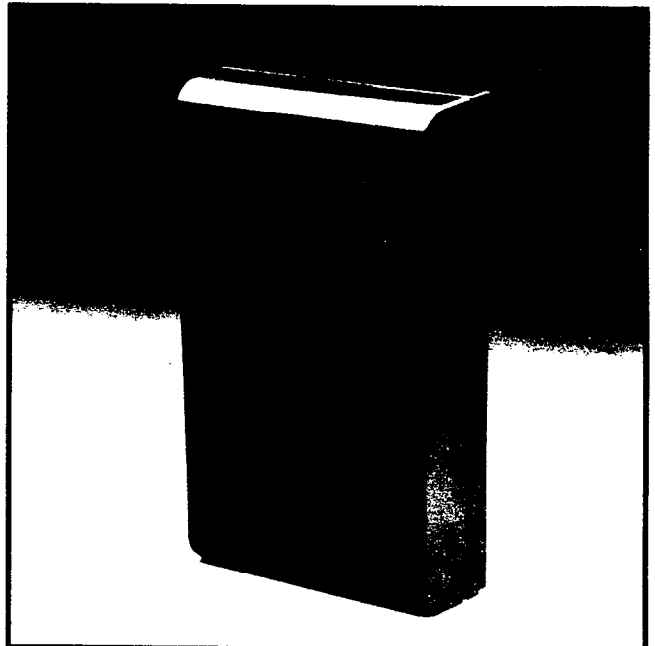

FIGURE 13—DOOR PHONE

Installation

The HKSU is configured for wall mounting only.

All external devices are connected to the HKSU via connectors and terminals on the side panels, as follows:

- a) CO/PBX lines are connected to the HKSU right side panel via two 3-pair or six single-pair modular cords.
- b) The station connection points are extended from the HKSU to the MDF using 2-pair modular line cords. The individual EKTs are connected to the MDF using 2-pair station cables.
- c) A screw-terminal barrier strip is mounted on the left-hand side of the HKSU to provide attachment points for the music-on-hold source input, relay service and external page output.
- d) Two modular connectors are also provided on the left side panel for two optional off-premises line modules (HOLBs).

The power supply is mounted inside the HKSU (an optional battery backup PCB is available for the power supply).

Maintenance

Faults in the system are repaired by replacing any faulty component (PCB, sub-assembly, telephone, etc.) and returning it to the manufacturer for repair.

07 FEATURES and OPERATION

General

This section contains brief descriptions of the features listed earlier in Tables B and C and some associated operating instructions. Detailed operating instructions can be found in the EKT **USER GUIDE**.

Standard Features

System

All Call Voice Page: Dialing a 2-digit access code permits a station user to page via all idle EKT speakers simultaneously. The system can also be programmed to include the External Page feature in an All Call Page.

Automatic Dialing-System: Allows 40 numbers to be stored in the system memory. After selecting an outgoing line, any station user can cause one of the stored numbers to be outpulsed by dialing the proper access code.

Automatic Hold Recall: A CO line placed on hold by any station will recall that station after a programmable period of time. A different time period can be selected for each station.

Automatic Release from Hold: The system automatically releases held CO lines if a disconnect signal is received from the central office.

CO Call Pickup: Using a dial code, allows CO call pickup from another station.

Conference (Multi-Station): Non-amplified conferencing is permitted to a maximum of four stations and one CO line. (Conferencing is not amplified.)

Conference (Multi-CO Line): The system will conference two CO lines and up to three stations. (Conferencing is not amplified.)

Distinctive Ringing: CO and intercom calls are distinguished by different ringing tones.

DTMF and Dial Pulse CO Line Compatible: The system will interface with either DTMF or rotary-dial pulse CO lines on a line-by-line basis as determined by system programming.

External Page Interface: A 600-ohm connection point is provided for a customer-provided external amplifier/speaker. The SEPU (see External Page Amplifier) can be mounted in the HKSU when only a customer-provided external speaker is used; the output impedance will be 8 ohms. This page circuit can be accessed as part of the All Call Voice Page feature.

Flexible Key Assignment: Allows each EKT to be programmed for optimum use of its CO/PBX or feature keys.

Flexible Line Ringing Assignment: A programmable ring or no ring option is provided for each line selectively by each sta-

tion. Each line may be programmed to ring a maximum of eight stations.

Forced Account Code: Requires selected station(s) to dial an account code prior to dialing a number. The account code is recorded with call details on the SMDR report.

Group Paging: Special 2-digit access codes (81, 82, 83 or 84) permit voice paging to one of four zones. Zone assignment is via software and is totally flexible. Paging is via the speakers of idle EKTs.

Live System Programming: Live system programming is accomplished without service interruption to other station users by placing the system in the special programming mode and inputting data via station 17. Station 17 is the only station that is "down" during programming.

Message Waiting: Any station (including the designated Message Center) can set a Message Waiting LED at any station with the Message Waiting LED of that station. The called station cancels the LED by lifting the handset and depressing the **MW/FL** key (not available on single-line EKT). Also see Flash key.

MF Signal Time (160/80 ms): The standard MF dial signal time is 80 milliseconds, but it may be extended to 160 milliseconds, if required by the CO or to activate remote equipment.

Multiple Simultaneous Handsfree Intercom Paths: Two intercom paths are available in the system. Both intercom lines are able to carry handsfree conversation simultaneously.

Music-On-Hold Interface: An interface is included for a customer-provided music source. CO lines placed on hold will be connected to this source. In addition, this music may also be broadcast from EKT speakers and external page when the background music programming options are selected.

Night Ring Answer Code: A night ringing call may be answered from any station via a dial code.

Night Ringing Over External Page: As a programmable option, while the night mode is active, a system-generated ring tone will be transmitted via the external speaker whenever any line rings.

Night Transfer: On a programmable optional basis, the system can function with two or three ringing patterns. If three patterns are selected, they are designated DAY, DAY 2, and NITE. If the two-pattern mode is selected, DAY and NITE designations are used. In both cases, the ringing modes are selected with the **NT** key on station 10.

Non-blocking Dialing: Dialing is permitted on intercom and all CO lines simultaneously.

Outgoing Call Restriction: Any station can be selectively restricted from originating calls on any or all CO lines. However, the station may still receive calls on the restricted line(s).

PBX Compatible: All of the system's features, such as Toll Restriction and Automatic Dialing, are compatible with PBX operation.

Privacy/Non-Privacy: A private system prevents other stations from accessing the intercom or CO lines that are already in use. A non-private system provides conferencing on the CO and intercom lines.

Private CO Lines: Restrictions may be programmed into the system so that selected CO line(s) will appear only on selected station(s).

Relay Service: The VMAU PCB is equipped with relays that provide the following signals for external equipment:

a) **External Page:** The relay is activated whenever the external page circuit is accessed. A dry "make" contact is provided for control of background music on external page. This is required only when an external page amplifier is used.

b) **Night Relay Service:** The relay will provide a dry "make" contact at the **NR** terminals on the left side panel. A strap option on the VMAU allows the NR relay to function in one of two modes:

STRATA VI_e
GENERAL DESCRIPTION
NOVEMBER 1986

- 1) **Answering Machine Control:** If the strap remains intact, the relay is operated continuously when the system is in night service. This mode is intended for indirect control of an answering machine.
- 2) **Night Bell Control:** If the strap is cut, the relay pulses at a 1-second on/3-seconds off rate whenever the system is in Night Transfer mode and an incoming call is ringing the system. This mode is intended to be used for indirect control of an external night bell.

Toll Restriction (6-digit): Selectively programmed on a station class of service basis. The system performs toll restriction by analyzing the first 6 or 3 digits (area/office code) dialed. Simple restriction by rejecting the numbers **0** and **1** can be programmed on a per-station basis, if desired.

Toll Restriction Override by System Automatic Dialing: A programmable system feature that permits numbers stored by the Automatic Dialing-System feature to be called by toll-restricted stations.

Voice or Tone Signalling: A programmable system feature that optionally selects either tone ringing or voice page as the primary method of intercom call signalling. The calling station, however, may choose the alternate method by dialing **1** following the station number.

Wall Mountable HKSU: The HKSU is designed for wall mounting only.

Station

Automatic Callback (Intercom): Permits a station user who encounters a busy station on intercom to request a callback by depressing the dedicated key. The system then monitors the called station and signals the caller when that station becomes idle.

Automatic Dialing-Station: Provides a private automatic dialing list of 40 numbers for each station in the system. The Flash and Pause functions may also be stored when necessary.

Automatic Off-Hook Selection: Allows CO line, CO group or intercom access by merely lifting the handset; depressing a CO/intercom key is not required.

Busy Override: After calling a busy station and receiving a busy tone, the caller can dial **2** and cause a tone burst to be sounded via the called EKT's speaker.

Call Forward: Allows *all calls* to a station to be routed to another station. The activating station may be used to originate calls while this feature is active.

Call Pickup: Enables a station to pick up calls ringing at other stations or an external page by going off-hook and dialing an access code. Call Pickup (**CPU**) keys can be assigned to EKTs to automatically pick up calls.

Call Transfer with Camp-on: Allows the transfer of an outside call to a station that is either idle or busy.

Directed Call Pickup: *All calls* ringing at another station can be answered from any station by that station going off-hook and dialing the ringing station's number.

Direct Station Selection (DSS) Keys: By depressing an assigned key, a station user causes the selected EKT to ring. A maximum of two DSS keys may be assigned per EKT.

Do Not Disturb: This feature is activated and deactivated by alternate depressions of the **DND** key. A station calling a station that is in the DND mode will receive a fast busy tone.

Do Not Disturb Override: After reaching a DND station, that station may be advised that a call is waiting by dialing **2**. A tone signal will be heard at the DND station.

DP/MF Mode Change (TONE) Key: Allows a station to change between DP and MF modes via the **TONE** key, as required.

Exclusive Hold: Depressing the **HOLD** key twice holds that call securely for the station that placed it on hold.

Executive Override (Break-In): A station programmed for this feature will override

the automatic privacy feature and enter any existing conversation within the system. A warning tone, however, is inserted before the overriding station is actually connected. After reaching a busy station, dial a **3** to override.

Flash Key (PBX Transfer or CO Dial Tone Recall): EKTs can be equipped with a Message Waiting/Flash (**MW/FL**) key which, when operated while connected to a CO/PBX line, causes a timed "flash" to be transmitted to the CO or PBX. The timing of the flash can be programmed to signal a PBX for feature operation or can be long enough to cause a disconnect and dial tone recall on a CO line (not available on single-line EKT). Also see Message Waiting.

Handsfree Answerback: All EKTs (except the single-line EKT) are equipped for handsfree answerback on voice-announced intercom calls as a standard feature.

I-called Illumination: A distinctive flash appears on the intercom LED at the EKT that is actually being called.

I-hold Illumination: The EKT user is shown a distinctive LED flash to indicate a line placed on hold at the EKT. Other stations see a normal on-hold flash.

I-use Illumination: A distinctive flash rate shows the line presently in use at a given EKT. Other stations see a steadily illuminated LED for that line.

Modular Handset and Line Cords: All EKTs are equipped with modular handset and line cords, and (except for the single-line EKT) are also equipped with an additional modular headset jack.

On-Hook Dialing: The system allows you to dial your calls with the handset still on-hook. Call progress can be heard via the telephone speaker; no need to pick up the handset until your party answers.

Push-Button Dialing: All EKTs are equipped with push-button dial pads.

Repeat Last Number Dialed: The last number dialed by each station is always

stored by the system and will be dialed automatically whenever the station user accesses a CO line and depresses the **#** or **RDL** key.

Ringing Line Preference: A line ringing a station can be answered by lifting the handset or depressing the **SPKR** key. The ringing line will be automatically selected.

Saved Number Redial: A programmable key that saves a dialed number for redial at a later time. May be used at any time and is exclusive of the Repeat Last Number Dialed feature.

Station Security (MCO Key): Allows each station to individually enable or disable the Handsfree Answerback feature.

Station-to-Station Message Waiting with LCD: An EKT's station number may be sent to another station, indicating that the displayed station has called. See 20-key Liquid Crystal Display EKT.

Trunk Queuing: Provides a means for station users to be "stacked" in a waiting queue for a busy outgoing trunk group by using the Automatic Callback feature. The station will then be signalled when a trunk in the group becomes available. As a programmable option, the system may be equipped with one trunk group (dial 9) or four trunk groups (dial 91, 92, 93, 94).

Optional Features

Background Music with Station Control: Music from the music-on-hold source can (at the station user's option) be heard via the EKT speaker. The same music may also be broadcast via the external page interface if an external speaker is installed.

Door Phone/Monitor Station: Allows optional door phone unit(s) to distinctively ring pre-selected EKTs. EKT dialing to an individual door phone unit provides monitoring capabilities on the intercom.

- **Alarm Key:** Turns off the alarm signal set in the system by a customer-supplied alarm system. The alarm signal is activated by a closure at the HDCB door phone C output from a customer-supplied alarm system. The alarm signal

STRATA VI_e
GENERAL DESCRIPTION
NOVEMBER 1986

will be heard from all idle EKTs until the alarm key is depressed (station 10 only).

- **Door Lock Key:** Activates a dry contact relay closure for indirect control of a door lock or other devices. When the key is depressed, the HDCB door phone B output will close for a period of 3 or 6 seconds.

EKT Faceplates (Blue, Black or Wine): The standard brown faceplates can easily be changed on any EKT to coordinate with office decor.

External Page Amplifier: This optional external page 3-watt amplifier (SEPU PCB) allows access to a customer-provided external 8-ohm speaker for paging.

Music-On-Hold Source: When installed, this optional electronic music source (SMOU PCB) eliminates the need for a customer-provided external music source and provides electronic-generated music to CO lines placed on hold.

Off-Premises Extension: Installing an optional HOXB allows the system to interface with conventional, single-line telephones or off-premises circuits. The HOXB (one per system) serves two extensions and replaces two EKTs in the system.

- **MRGU:** An auxiliary ringing/power supply for the HOXB.

Off-Premises Line: Installing an optional HOLB allows the bridging of a CO/PBX line that appears in the system with a conventional telephone (or other device, such as a modem). During Night Service, all incoming calls on an HOLB's three circuits may be directed to an answering machine (or similar device) connected to a "hunting" output. This option is set in programming.

Station Message Detail Recording (SMDR): Adding the optional HSMB allows data to be collected for each outgoing and incoming CO line call. This data is output to a printer or recording device via the RS-232C interface located on the HSMB. The HSMB is externally mounted.

System Battery Backup: An optional module (HPBU-7) can be installed in the power supply to provide automatic switching to standby battery power. During normal power conditions, the batteries are kept fully charged by the power supply.

Single-Line EKT: An EKT with three permanently dedicated keys (**HOLD CONF SPKR**) and an intercom/CO line key, which is not labeled.

10-key EKT (HFU or Speakerphone): A basic EKT with full speakerphone capability or handsfree answerback (HFU) only, depending upon the requirements.

10-key Busy Lamp Field (BLF) EKT: A 10-key EKT with full speakerphone capability and an LED panel showing the busy/idle status of each station. A station in the DND mode will show as busy.

20-key EKT (HFU or Speakerphone): A 20-key EKT with full speakerphone capability or handsfree answerback only, depending upon the requirements, plus 10 additional feature keys.

20-key Liquid Crystal Display (LCD) EKT: This 20-key EKT features a 32-character alphanumeric (12-digit display in current release) Liquid Crystal Display (LCD), full speakerphone capability, and the same key flexibility as the 20-key EKT. See Station-to-Station Message Waiting with LCD.

Strata[®] ***VI_e***

INSTALLATION PROCEDURES

Strata VI_e

INSTALLATION PROCEDURES

TABLE of CONTENTS

PARAGRAPH	SUBJECT	PAGE
	TABLE of CONTENTS	i
	ILLUSTRATION LIST	iii
01	GENERAL	1
02	PACKING	1
02.00	Inspection	1
03	HKSU REQUIREMENTS	1
03.00	Power Requirements	1
03.10	Ventilation Requirements	1
03.20	Environmental Factors	1
03.30	Cabling Considerations	1
04	HKSU INSTALLATION	2
04.00	Wall Mounting the HKSU	2
04.10	Explanation of PCB Functions	2
04.20	Power Supply	3
04.30	Test Procedures	4
04.40	PCB Installation	4
05	PERIPHERAL EQUIPMENT INSTALLATION	5
05.00	General	5
05.10	HSMB Installation	6
	TABLE 1—RS-232C Pin Connections	7
05.20	HOXB Installation	7
05.30	HOLB Installation	7
05.40	HDCB Installation	7
06	CABLE CONNECTIONS	8
06.00	Main Distribution Frame Configuration	8
06.10	Station Cable Connections	8
06.20	Door Phone/Monitor Stations Connections (HDCB/MDFB)	8
06.30	Intercom Code Assignment	9
06.40	CO Line Connection	10
06.50	Off-Premise Extension/Conventional Telephone Connections (HOXB)	10
06.60	Off-Premise Line Connection	11
06.70	Station Message Detail Recording Connections	12
07	EKT INFORMATION	12
07.00	General	12
07.10	EKT Wall Mounting	14
07.20	EKT Connections	15
08	SYSTEM POWER-UP INITIALIZE	15
08.00	General	15
08.10	Clearing Automatic Dialing	15
08.20	SMDR Real-Time Clock Adjustment	16
08.30	Program Listing	17

Strata VI_e

INSTALLATION PROCEDURES

TABLE of CONTENTS (continued)

PARAGRAPH	SUBJECT	PAGE
09	SYSTEM TEST PROCEDURES	17
09.00	EKT Functional Check	17
09.10	Off-Premise Extension/Conventional Telephone Functional Check	18
09.20	OPL Circuit Functional Check	19
09.30	SMDR Functional Check	20
09.40	Feature Check	20
10	MISCELLANEOUS EQUIPMENT CONNECTIONS	20
10.00	Wiring Connections	20
10.10	MOH/BGM Source	20
10.20	Music-On-Hold Volume Control	20
10.30	External Paging Connections	20
10.40	Direct External Speaker Connection	21
10.50	External Amplifier Connection	21
10.60	Talkback Amplifier	21
10.70	Background Music	22
10.80	Volume Setting Sequence	22
10.90	Night Relay Service	23

Strata VI_e
INSTALLATION PROCEDURES
ILLUSTRATION LIST

NUMBER	TITLE	PAGE
1	VCCU Battery Strap	1
2	HKSU Side Covers	2
3	HKSU Wall Mounting	2
4	HKSU (with PCBs)	2
5	HPBU Installation	3
6	HKSU Cover Removal	4
7	SSTU Location(s)	5
8	SEPU Location	5
9	VCOU Location	5
10	External Module Wall Mounting	6
11	HSMB Connection Straps	7
12	HOXB Connection Straps	7
13	HDCB Connection Straps	8
14	System Diagram	9
15	EKT Wiring	8
16	RJ-11C/RJ-25C Color Code	10
17	HDCB/MDFB Connection	10
18	HKSU Right Side Panel	10
19	HOXB Wiring	11
20	HOLB Wiring	11
21	HSMB/Printer Cabling	12
22	10-key EKT	12
23	10-key BLF EKT	13
24	20-key EKT	13
25	20-key LCD EKT	13
26	Removing EKT Base	14
27	EKT Wire Access	14
28	EKT Wire Routing	14
29	Handset Hanger	15
30	VCCU Battery Strap	15
31	Initialize Switch	15
32	HSMB Switches and LEDs	16
33	SMDR Printout Example (Outgoing Call Record)	20
34	SMDR Printout Example (Incoming Call Record)	20
35	Terminal Strip	21
36	Impedance Switch	21
37	External Amplifier Hook-up	22
38	Volume Setting Controls	22
39	Relay Contacts	23

01 GENERAL

01.01 This section describes the installation procedures necessary to ensure proper operation of the **Strata Vle** system.

02 PACKING

02.00 Inspection

02.01 When a **Strata Vle** system is received, examine all packages and carefully note any visible damage. If any damage is found, bring it to the attention of the delivery carrier and make the proper claims.

02.02 Check the number of cartons and the contents of the **Strata Vle** shipment against the purchase order and packing slip. If it is determined that any cartons are missing, contact your delivery carrier immediately. If it is determined that any equipment within a carton is missing, contact your Toshiba supplier immediately.

02.03 After unpacking (prior to beginning the installation), inspect all equipment for damage. If any damage is detected, contact your delivery carrier immediately. If possible, retain all the original packing material.

CAUTION!

When handling (installing, removing, examining, etc.) a printed circuit board, do not touch the back (soldered) side or the pin connector. Always hold a PCB by its edge.

02.04 When packing or storing a VCCU, ensure the following:

- **Do not** use plastic or any type of conductive material for packing a VCCU. Use plain paper.

CAUTION!

Conductive packing material may cause the internal back-up battery to discharge and damage the PCB.

02.05 Whenever storing or shipping a VCCU, always ensure that the battery strap is in the OFF position (see Figure 1).

03 HKSU REQUIREMENTS

03.00 Power Requirements

03.01 The **Strata Vle** HKSU requires 24

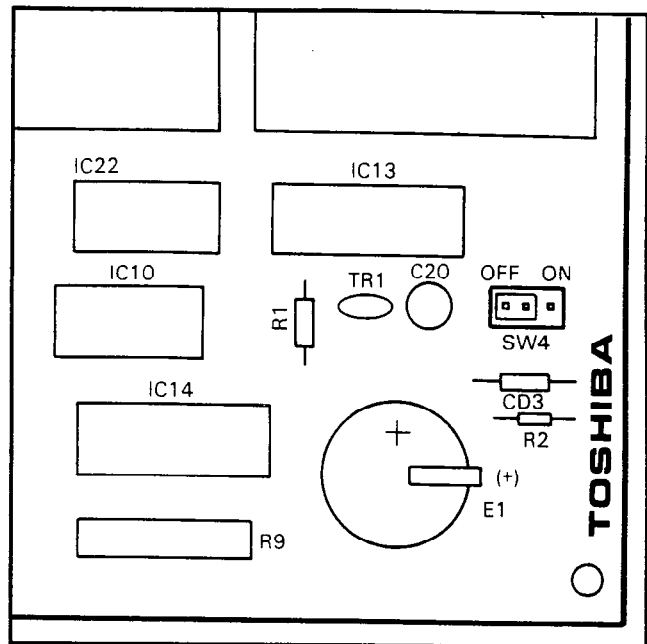

FIGURE 1—VCCU BATTERY STRAP

VDC. This is provided by the internal power supply (HPSU 7120), which in turn requires power from a grounded 115 VAC outlet. The outlet should be separately fused and rated at 15 amps.

03.02 An optional battery back-up unit (HPBU-7) is available for the HPSU 7120. With the optional battery assembly installed, all functions of the **Strata Vle** system will continue to operate for approximately 2 1/2 hours after a loss of normal electrical power. No calls will be disconnected during switch-over to battery power.

03.10 Ventilation Requirements

03.11 Sufficient ventilation should exist to allow dissipation of the heat generated by the power supply and HKSU.

03.20 Environmental Factors

03.21 Humidity at the HKSU location should be within 20 - 80% (without condensation), and the temperature should be relatively constant within a range of 32 - 122° F (0 - 50° C). Exposure to dust and airborne chemicals should also be taken into consideration.

03.30 Cabling Considerations

03.31 The HKSU must be located so that all stations are within 1,000 cable feet (305 M) of it. Acceptable cable is 22 or 24 AWG inside

INSTALLATION PROCEDURES
SECTION 300-006-200
MAY 1986

telephone station cable (jacketed but not shielded), having two or more twisted wire pairs.

04 HKSU INSTALLATION

04.00 Wall Mounting the HKSU

04.01 To mount the HKSU on the wall, perform the following steps:

1) Remove both side covers from the HKSU (refer to Figure 2) by pressing in on the two small ribbed sections on each side cover to free the holders.

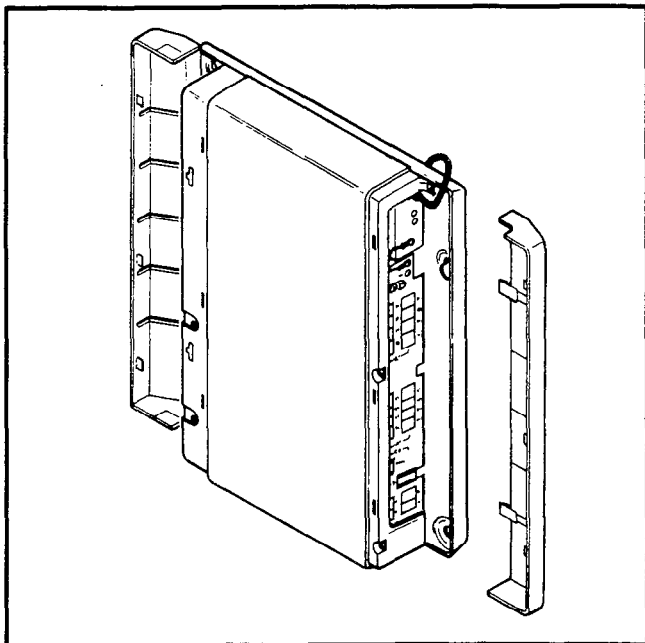

FIGURE 2—HKSU SIDE COVERS

2) Hold the HKSU against the wall in its planned location and mark the screw locations through the centers of the two keyholes on the upper sides of the HKSU.

3) Lay the HKSU aside for the moment and start two screws into the wall at the marked locations. Use 1 1/4" panhead wood screws and stop when they have penetrated to half their depth.

4) Hang the HKSU on the two screws and start two additional screws in the lower two holes. Tighten all four screws.

5) Knockouts are provided on the top and bottom of the side covers to permit cables to enter the HKSU. Remove the appropriate knockouts.

6) Reinstall the side covers.

7) A completed installation should appear as shown in Figure 3.

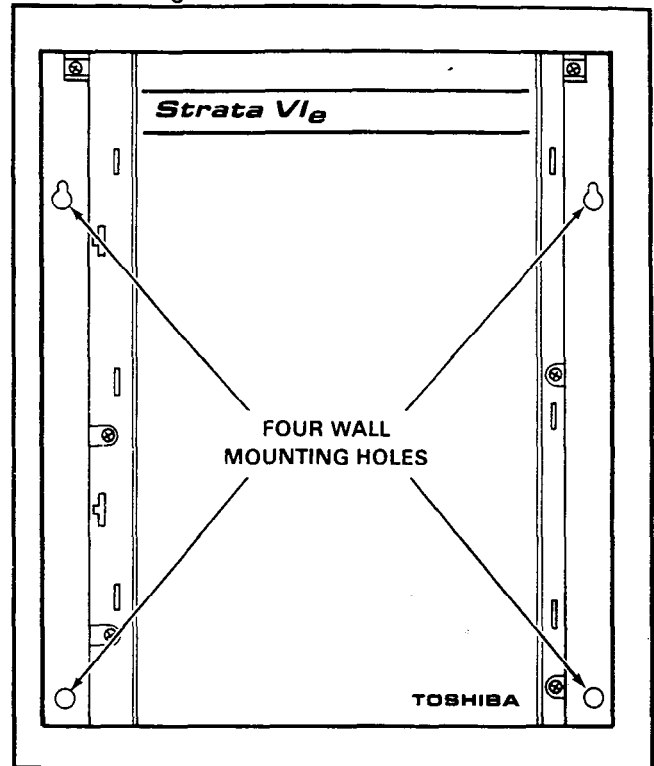

FIGURE 3—HKSU WALL MOUNTING

04.10 Explanation of PCB Functions

04.11 A maximum of seven PCBs can be installed in the *Strata VIe* HKSU, as shown in Figure 4. The functions of these PCBs are:

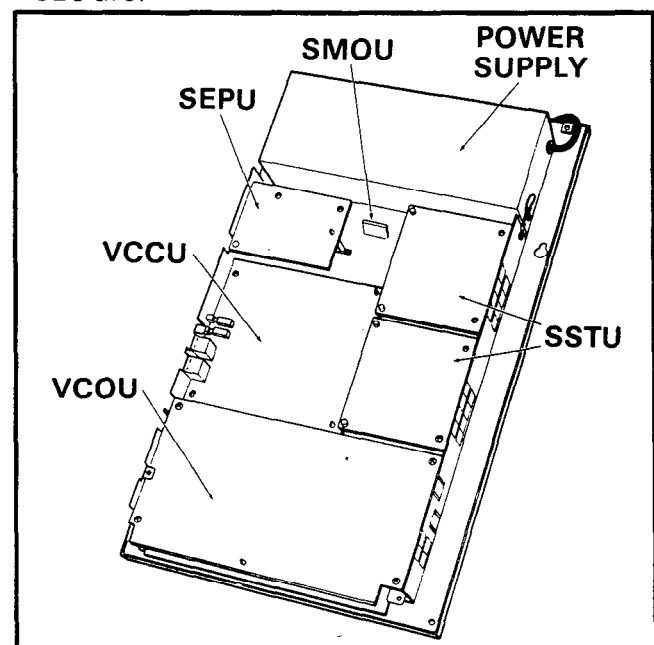

FIGURE 4—HKSU (with PCBs)

VMAU: The main PCB of the HKSU provides the following three functions:

a) **Station Interface**—An interface between the HKSU and up to eight EKTs, which includes the solid-state space division matrix used for voice connections between the EKTs and the CO/PBX lines. Two-pair wiring is required for each EKT; one pair carrying voice and the other pair carrying control data to and from the EKT.

b) **CO Interface**—An interface between the HKSU and the public telephone network or PBX for three lines. Ring detection, hold and dial outpulsing for the three lines are performed by this PCB. Depending upon local CO requirements, the VMAU is programmed to provide DTMF or rotary dial outpulsing.

c) **Tone**—Performs a number of miscellaneous system functions:

- Generates system tones.
- Provides switching matrix for tone delivery of paging and intercom connections.
- Houses interface for the external page.

VCOU: An optional interface between the VMAU and three additional public telephone network or PBX lines. Depending upon local CO requirements, the VCOU is programmed to provide DTMF or rotary dial outpulsing (serves up to three CO/PBX lines).

SSTU: An optional interface between the HKSU and stations 18 - 21 and/or 22 - 25. Each SSTU PCB serves up to four EKTs. Two-pair wiring is required for each EKT; one pair carrying voice and the other pair carrying control data to and from the EKT.

VCCU: All system control functions are performed by the single-chip microprocessor on this PCB. The system program stored in ROM, the RAM for system operations, and the RAM for system data storage are also located on this circuit board.

SMOU: An optional music-on-hold source that provides electronic synthesized music. It is connected to the VMAU via a 7-pin connector.

SEPU: An optional 3-watt amplifier for external paging. The SEPU is attached to the left side panel of the HKSU and connected to the VMAU via one 10-pin connector.

04.20 Power Supply

04.21 The system requires 24 VDC, which is provided by the internal, factory-installed power supply (HPSU). The HPSU requires 115 VAC, 60 Hz, with a permissible AC input voltage range of 90 - 130 VAC.

04.22 An optional battery back-up unit (HPBU-7) is available. It is a PCB that mounts inside the power supply housing (Figure 5) and is connected to the female 3-prong connector inside the power supply's case. Secure the HPBU with the two provided screws.

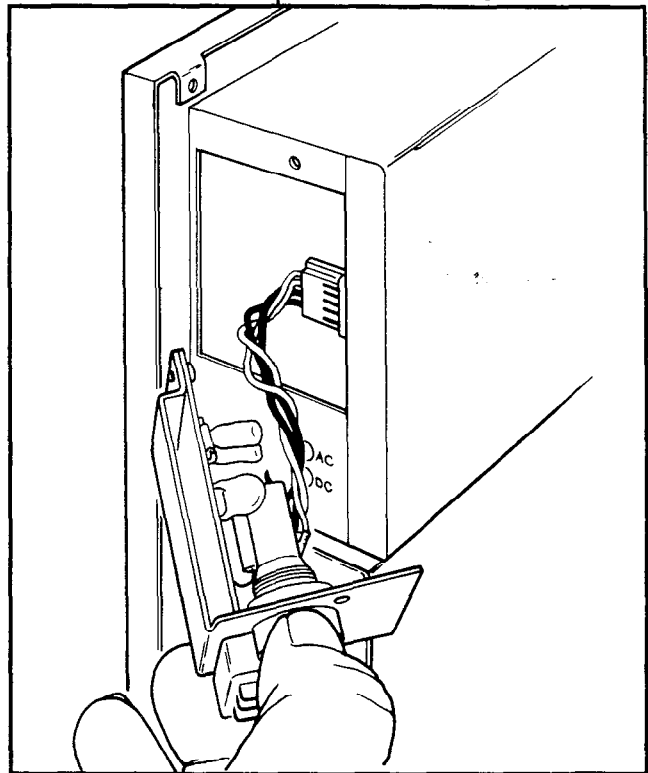

FIGURE 5—HPBU INSTALLATION

04.23 The HPBU is then connected via the terminal block to the recommended battery pack (which is customer-supplied, consisting of two 12 VDC, maintenance-free, automobile-type batteries—80 amp/hour maximum rating). With the optional battery back-up assembly installed, all functions of the system will continue to operate for several hours (the actual time period is in direct ratio to the type and size of batteries selected).

04.24 The Toshiba *Strata VI_e* electronic key telephone system requires a solid earth ground. Failure to provide such a ground may lead to confusing trouble symptoms in the sys-

INSTALLATION PROCEDURES
SECTION 300-006-200
MAY 1986

tem and, in extreme cases, circuit board failure. In most installations (within the continental United States), the ground provided by the "third wire ground" at the commercial power outlet will be satisfactory for all **Strata VI_e** requirements. However, in a small percentage of installations, this ground may be installed incorrectly. Therefore, prior to installing a system, the third wire ground must be tested for continuity by either measuring the resistance between the third prong terminal (earth ground) and a metal cold water pipe, or by using a commercially available earth ground indicator. If neither procedure is possible, then the test procedures outlined in Paragraph **04.30** should be performed.

WARNING!

Hazardous voltage is exposed during the following test. Use great care when working with AC voltage.

04.30 Test Procedures

- 1) Obtain a suitable voltmeter and set it for a possible reading of up to 250 VAC.
- 2) Connect the meter probes between the two main AC voltage points on the wall outlet. The reading obtained should be 90 - 130 VAC.
- 3) Move one of the meter probes to the third prong terminal (GND). Either the same reading or a reading of 0 volts should be obtained.
- 4) If the reading is 0V, leave one probe on the GND terminal and move the other probe to the second voltage terminal. If a reading of 0V is obtained on both voltage terminals, the outlet **is not** properly grounded. Omit Steps 5 through 7 and proceed directly to Step 8.
- 5) If a reading of 0V on one terminal and a reading of 90 - 130 VAC on the other terminal is not obtained, the outlet **is not** properly grounded. Omit Steps 6 and 7 and proceed directly to Step 8.
- 6) If a reading of 0V on one terminal and a reading of 90 - 130 VAC on the other terminal is obtained, remove both probes from the outlet.
- 7) Set the meter on the "OHMS/Rx1" scale, place one probe on the GND terminal and the other probe on the terminal that produced a reading of 0V. A reading of less than 1 ohm

should be obtained. If a reading of more than 1 ohm is obtained, the outlet **is not** adequately grounded.

8) If the above tests show the outlet is improperly grounded, that condition should be corrected by a qualified electrician (per Article 250 of the National Electrical Code) before the **Strata** system is connected.

04.31 Ensure that the power switch on the HPSU is **OFF**, then plug the power supply into the 115 VAC outlet.

04.40 PCB Installation

04.41 The VMAU and VCCU are factory-installed in the HKSU.

04.42 If any optional PCBs (SSTU, SEPU, SMOU or VCOU) are required, refer to Figure 6 and remove the HKSU cover as follows:

- 1) Remove both side covers by pressing in on the two small ribbed sections on each cover to free the holders.
- 2) Remove three screws from each side of the HKSU per Figure 6.
- 3) Lift the HKSU cover off.

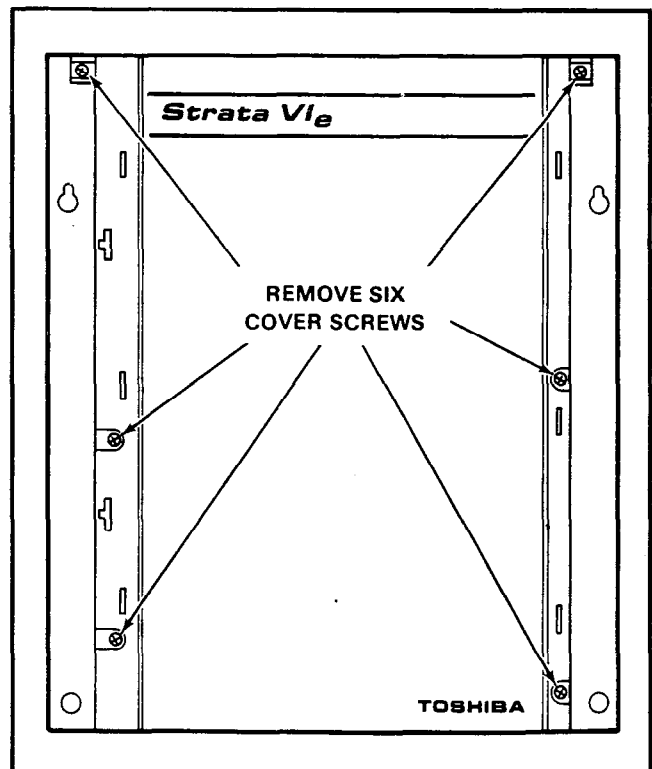

FIGURE 6-HKSU COVER REMOVAL

04.43 Refer to Figures 7, 8 and 9 for the various locations of the following optional printed circuit boards.

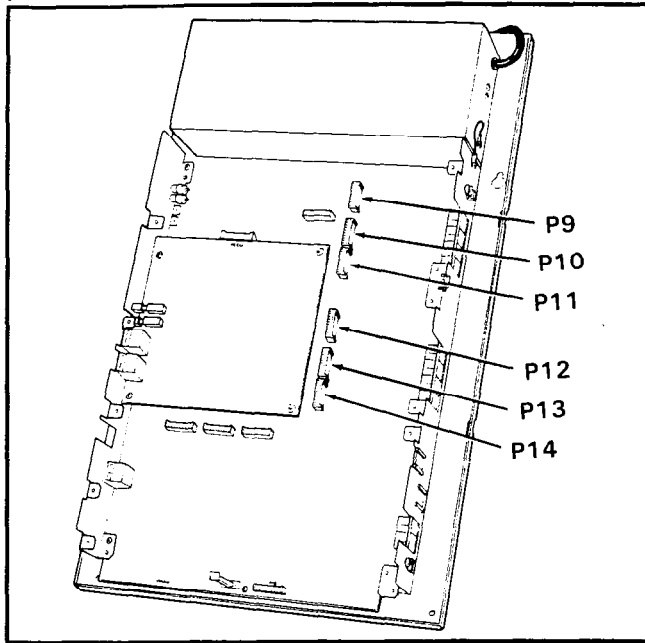

FIGURE 7—SSTU LOCATION(S)

SSTU: For adding stations 18 - 21, insert the three SSTU 10-pin connectors into **P9**, **P10** and **P11** connectors on the VMAU PCB. Secure the SSTU PCB to the right side panel with the two provided screws. (For stations 22 - 25, insert the three 10-pin connectors on another SSTU into **P12**, **P13** and **P14** connectors on the VMAU PCB. Secure the

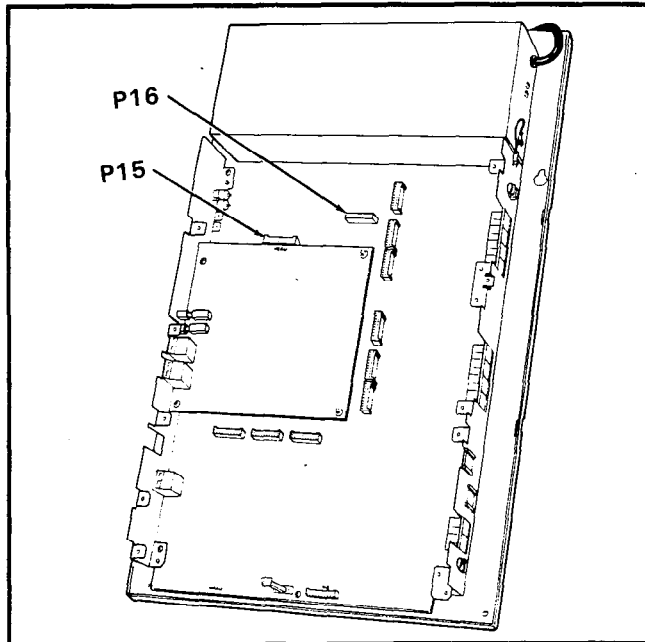

FIGURE 8—SEPU LOCATION

SSTU PCB to the right side panel with the two provided screws.)

SEPU: Install the SEPU into connector **P15** on the VMAU PCB. Slide the SEPU's corner hole over the white, plastic standoff support. Secure the SEPU to the left side panel with two screws.

SMOU: Install the SMOU PCB into connector **P16** on the upper center of the VMAU PCB (Figure 8).

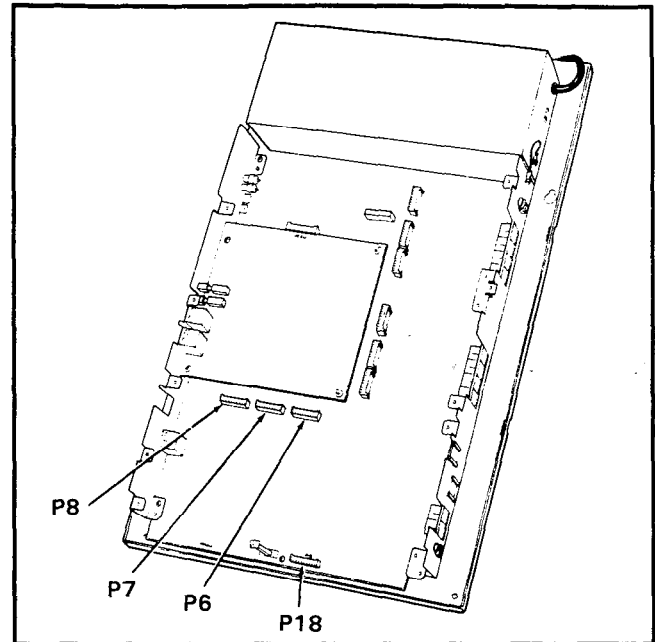

FIGURE 9—VCOU LOCATION

VCOU: The VCOU PCB mounts on four 10-pin connectors and one plastic standoff at the bottom of the VMAU PCB. Install the VCOU's three 10-pin connectors into the VMAU's **P6**, **P7** and **P8** connectors and the fourth one into **P18**. Secure the VCOU to the left and the right side panels with two provided screws on each side.

04.44 Reinstall the HKSU top cover and side covers in the reverse order of the previous instructions.

05 PERIPHERAL EQUIPMENT INSTALLATION

05.00 General

05.01 Several **Strata V1e** features are provided by external peripheral modules. Four of these are:

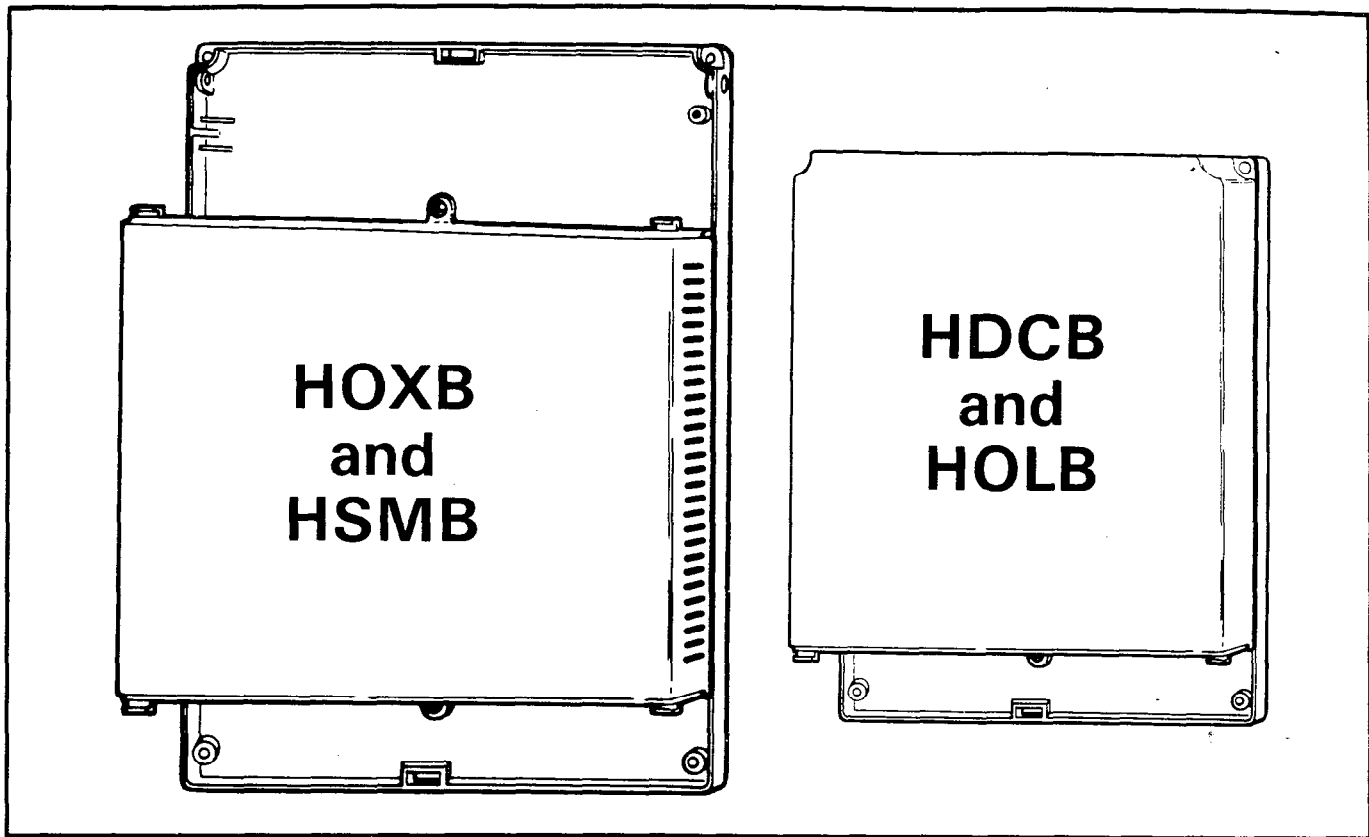

FIGURE 10—EXTERNAL MODULE WALL MOUNTING

- a) **HSMB:** Provides Station Message Detail Recording (SMDR) features.
- b) **HOXB:** Provides Off-Premise Extensions for single line telephones.
- c) **HOLB:** Provides Off-Premise Line features for the system.
- d) **HDCB:** Provides Door Phone/Monitor Stations, Door Lock and Alarm features.

05.02 Although different in size, all four external modules are mounted in the same manner. Refer to Figure 10 and perform the following steps:

- 1) Remove the side cover(s) to expose all four corner mounting holes.
- 2) Properly position the module adjacent to the HKSU with regards to future wiring needs.
- 3) Secure the module to the mounting surface with the four provided screws.

05.03 Refer to the following paragraphs for installing the HSMB, HOXB, HOLB and HDCB, respectively. Cabling instructions are in Para-

graph 06.

05.10 HSMB Installation

05.11 To equip the system with Station Message Detail Recording (SMDR), install an HSMB option module.

05.12 The HSMB must be installed within 17' from the HKSU (however, a 7' cord is provided with the module), and connected by two 8-wire modular cables. Connect one modular cable from **J1** (CONT) on the HSMB to the **CONT** connector on the HKSU. Connect the other modular cable from **J2** (PW) on the HSMB to the **PW** connector on the HKSU. The RS-232C printer connector is installed at **J3** on the HSMB.

05.13 Remove the HSMB cover and locate the **SW8** battery strap (Figure 11) on the HSMB and connect the memory back-up battery. To connect the battery, install the strap-plug so that it bridges the center pin with the pin labeled **ON**.

05.14 Select the data output speed using the **SW7** strap. The speed may be set at 300

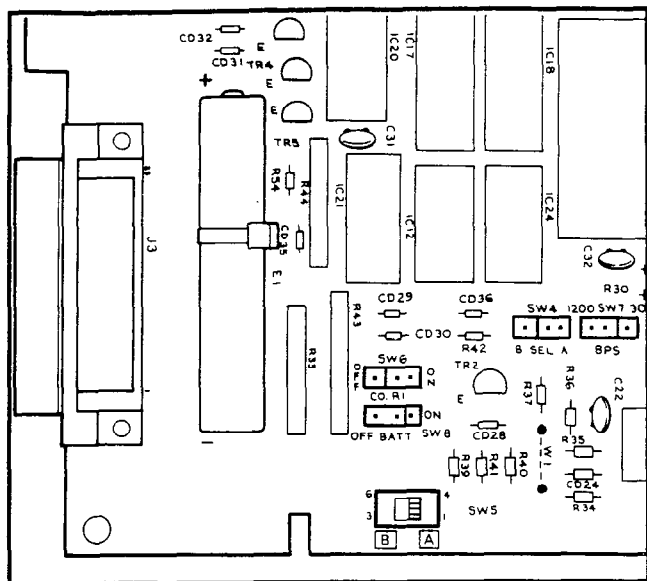

FIGURE 11

HSMB CONNECTION STRAPS

or 1,200 BPS by installing the strapping plug so that it bridges the center pin with the terminal labeled "300" or "1200".

05.15 Two other switches (**SW4** and **SW5**) located on the HSMB will normally be set at position A. In position B, the HSMB will accommodate other printer types. See Table 1 to determine the RS-232C pin connections for positions A and B.

Table 1—RS-232C Pin Connections

Position A		Position B	
3	RD	2	RD
20	DTR	3	STATUS
6	DSR	6	DSR
7	SG	7	SG
8	CD	8	CD

05.16 The SMDR feature will print out records of both incoming and outgoing calls or only outgoing calls. This option is selected by using the **SW6** strap. Installing the strapping plug so that it bridges the center pin with the terminal labeled **OFF** will cause both incoming and outgoing calls to be recorded.

05.20 HOXB Installation

05.21 To equip the system with conventional telephones or Off-Premise Extensions, install an HOXB external module. The MRGU, a ring generator and -48 VDC battery supply, is

also required. Refer to Paragraph **06.52** for additional information regarding the MRGU.

05.22 Remove the HOXB cover and locate the two operational mode straps on the HOXB PCB (mounted to the HOXB base). As shown in Figure 12, the straps are located in the center of the PCB (**SW1** controls the operation of OPX telephone #1; **SW2** controls OPX telephone #2). Set each switch to ON for dial pulse (DP) or OFF for DTMF (MF) tone output, as required. After setting the straps, reinstall the cover and secure it to the base.

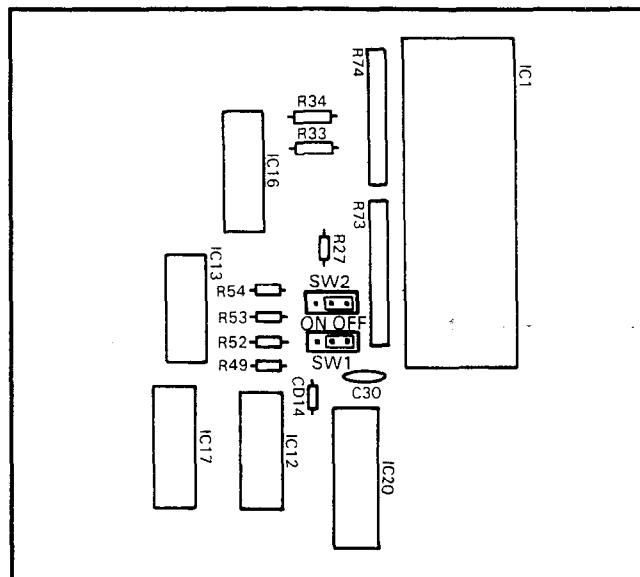

FIGURE 12

HOXB CONNECTION STRAPS

05.23 For correct cabling information, refer to Paragraph **06**.

05.30 HOLB Installation

05.31 To equip the system with the Off-Premise Line option, install the HOLB option module.

05.32 For correct cabling information, refer to Paragraph **06**.

05.40 HDCB Installation

05.41 To equip the system with up to three Door Phone/Monitor Stations or the Door Lock and Alarm features, install the HDCB external module. HDCB outputs B and C, respectively, may also function as door lock control and alarm signal inputs.

05.42 Remove the HDCB cover and locate

INSTALLATION PROCEDURES
SECTION 300-006-200
MAY 1986

(per Figure 13) **SW2** and **SW1** in the upper left corner (**SW1** controls output C; **SW2** controls output B).

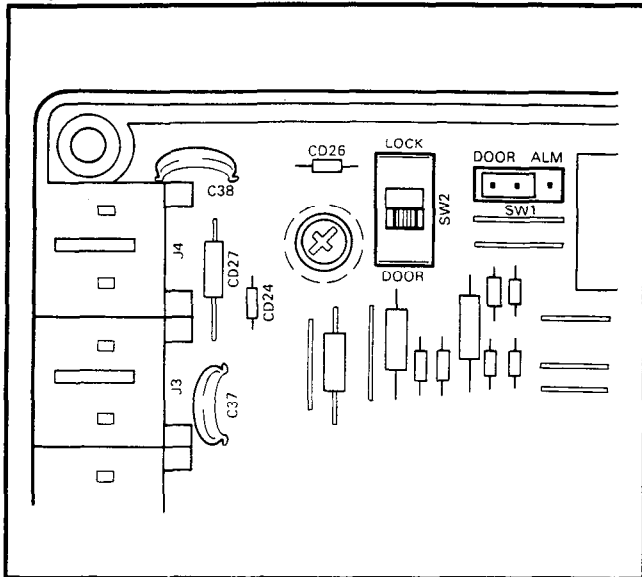

FIGURE 13

HDCB CONNECTION STRAPS

a) When **SW1** is in the "DOOR" position, output C connects to a door phone/monitor station. When strapped in the "ALM" position, output C will detect a closure across its two leads (a short) and provide an alarm signal to all idle stations. The signal may be turned off with an **ALRM** key on an EKT.

b) When **SW2** is in the "DOOR" position, output B connects to a door phone/monitor station. When strapped in the "LOCK" position, output B will provide a dry contact closure for indirect control of a door lock or other device. The closure will be for a period of 3 or 6 seconds (programmable) when an EKT's door lock (**DRLK**) key is depressed.

05.43 For correct cabling information, refer to Paragraph 06.

06 CABLE CONNECTIONS

06.00 Main Distribution Frame Configuration

06.01 Station cables are modular from the right side panel to the MDF block as shown in Figure 14.

06.10 Station Cable Connections

06.11 Using the industry-standard color code sequence, terminate the individual 2-pair

station cables consecutively on the MDF. Connect the HKSU cable pairs to the station cable pairs.

06.12 The cables used for station wiring should be twisted pair.

06.13 The overall length of the cable run must not exceed 1,000' (305 M) for 24 AWG wire.

WARNING!

When installing station cable, do not run parallel to and within 3' of an AC power line. Such power lines should be crossed at right angles (90°) only.

06.14 At the station locations, terminate the station cable in a conventional 4- or 6-conductor modular station connector to accommodate the modular line cord from the EKT. The standard modular EKT cord length is 7', while the maximum allowed length is 25'. Figure 15 shows the EKT wiring arrangement.

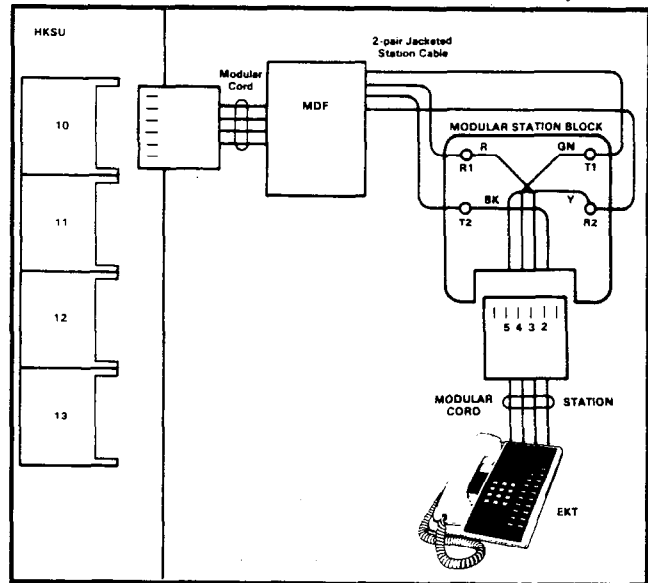

FIGURE 15—EKT WIRING

06.15 Various manufacturers of modular station blocks have employed different color codes to indicate the sequence of pairs in their blocks. However, the color code most commonly used is shown in Figure 16. Verify the configuration of your modular blocks before connecting the station cables.

06.20 Door Phone/Monitor Stations Connections (HDCB/MDFB)

06.21 The door phone control unit (HDCB) is

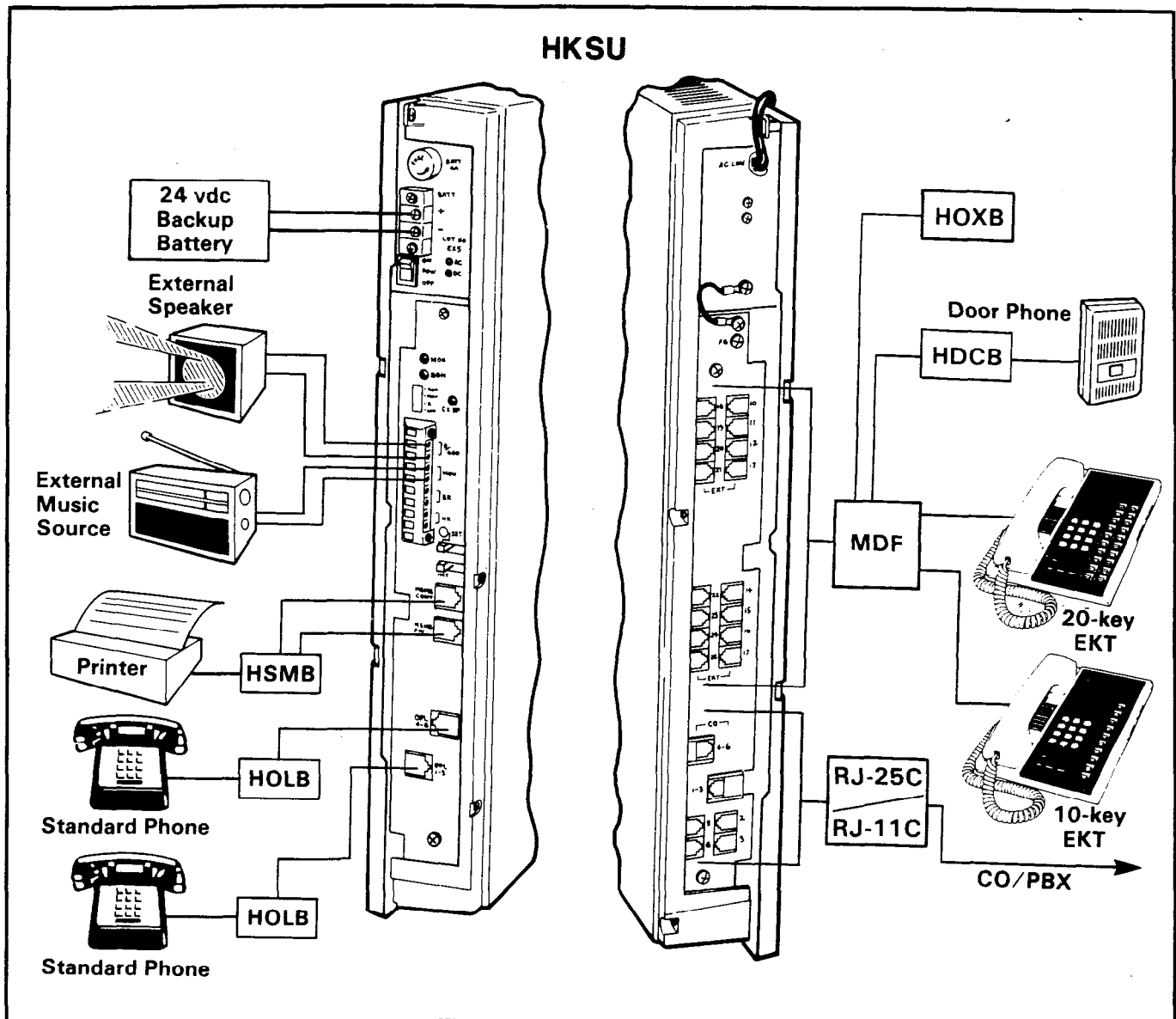

FIGURE 14—SYSTEM DIAGRAM

connected to the HKSU, via a standard EKT modular connector, at the EKT #13 or #14 modular connector (program-controlled).

06.22 The HDCB has three outputs (A, B and C), which are modular connectors for three door phone units (MDFBs). Outputs B and C can also be used for Door Lock and Alarm features, respectively.

06.23 Each door phone/monitor station (MDFB) is connected to the HDCB via a 2-wire modular connector at the HDCB and a split ring connector at the MDFB using screw terminals 1 and 2 (L1 and L2 are not used).

NOTE:

When using outputs B and C for Door Lock and Alarm features, respectively, an appropriate modular connector must be used to interface the HDCB to the door lock and alarm system devices.

06.24 Figure 17 shows the HDCB and MDFB wiring arrangement.

06.30 Intercom Code Assignment

06.31 Intercom codes (station numbers) are assigned permanently to specific cable appearances in *Strata V1e*. Make sure the station cables are connected to the proper terminals

INSTALLATION PROCEDURES
SECTION 300-006-200
MAY 1986

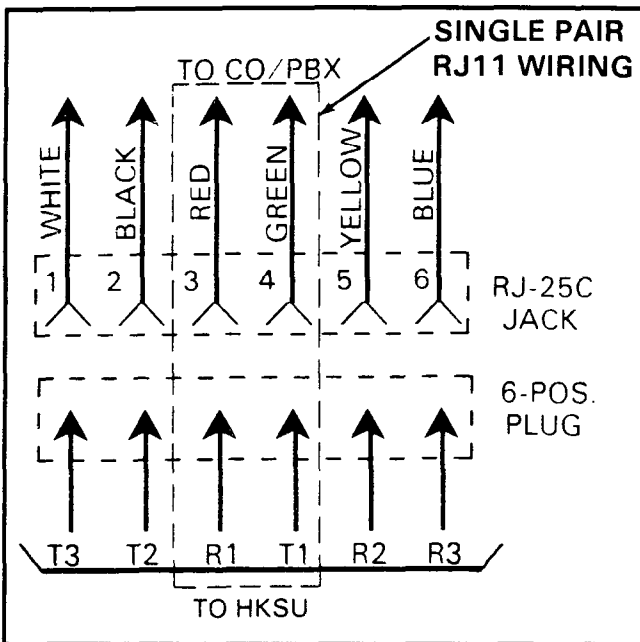

FIGURE 16
RJ-11C/RJ-25C COLOR CODE

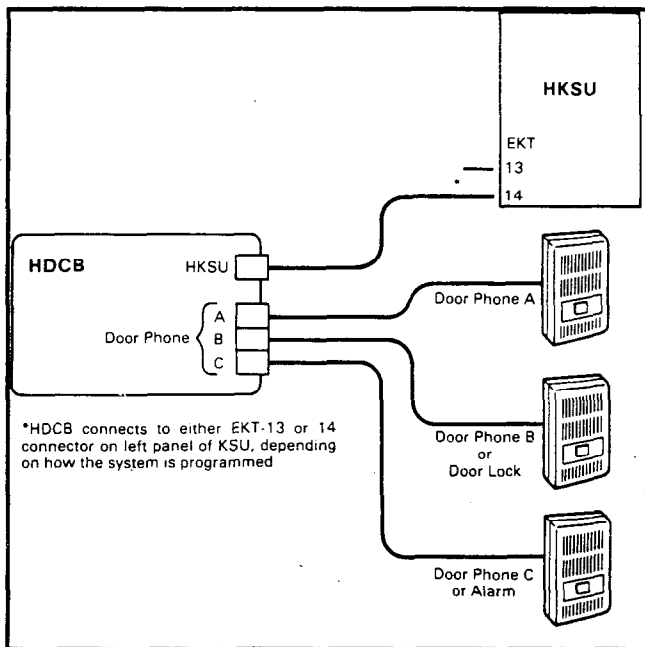

FIGURE 17
HDCB/MDFB CONNECTION

(see Figure 16).

NOTE:

White and blue (T3 & R3) are not used for **Strata V1e** station line connectors.

06.40 CO Line Connection

06.41 The CO/PBX lines are connected to

the **Strata V1e** system via 6-wire modular line cords (no longer than 25') that are connected directly to the 1-3 and 4-6 modular connectors on the right side panel (Figure 18). The opposite end of each cord then terminates directly into a locally provided RJ-25C jack (Figure 16).

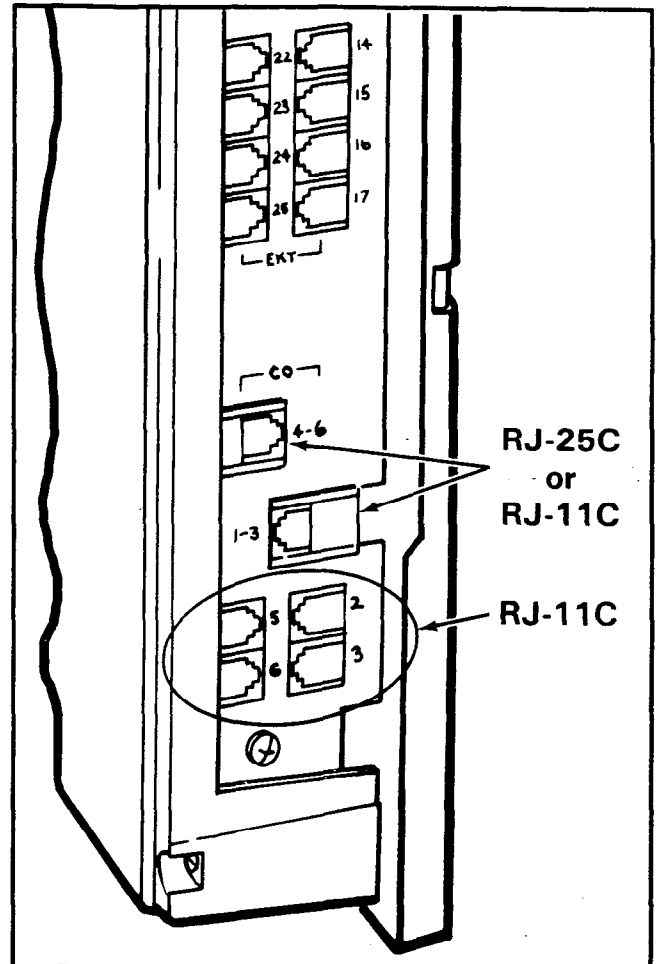

FIGURE 18—HKSU RIGHT SIDE PANEL

06.42 The CO/PBX lines may also be connected via 2-wire modular line cords to the connectors 1-3, 4-6, 2, 3, 5 and 6 on the right side panel (Figure 18). The opposite end of each cord then terminates directly into a locally provided RJ-11C jack (Figure 16)

06.50 Off-Premise Extension/Conventional Telephone Connections (HOXB)

06.51 Three types of wiring arrangements are necessary for off-premise extension/conventional single-line telephone (OPX) connections: HOXB-to-HKSU, HOXB-to-MRGU and HOXB-to-conventional, single-line telephones. See Figure 19.

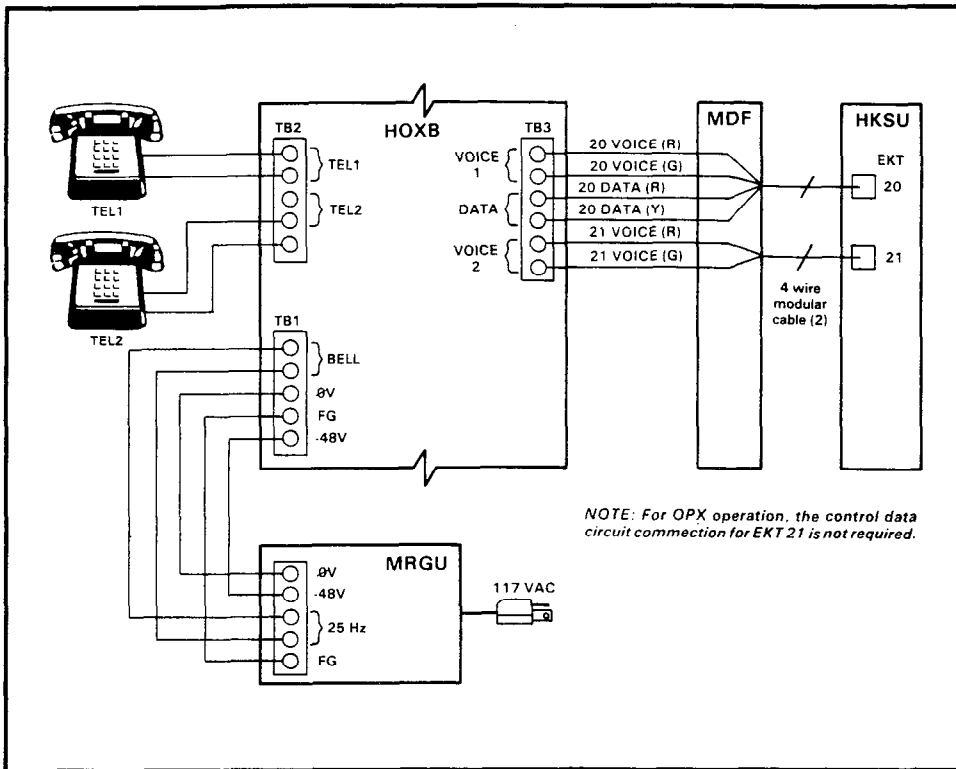

FIGURE 19—HOXB WIRING

1) HOXB-to-HKSU connections are made via a 4-wire modular cord from station 20 (on the HKSU) to the HOXB terminal strip (TB3) voice and control data terminals. A station 21 voice-only connection is required if a second OPX circuit is desired.

2) HOXB-to-MRGU connections are made from the MRGU output terminal strip to the HOXB terminal strip (TB1).

a) Connect 80 VAC, 25 Hz, output on the MRGU to the "BELL" input on the HOXB.

b) Connect the -48 VDC and 0 V battery terminals on both units, observing the correct polarity.

c) Connect FG to FG on both units.

IMPORTANT FCC INFORMATION:
HOXB and MRGU

are FCC registered with a facility interface code of 0L13A. If an alternate DC supply/ring generator is to be used, contact your Toshiba supplier for details.

3) HOXB-to-conventional single-line telephone connections are made from the telephone to the HOXB terminal strip (TB2) with industry-standard 2-, 4- or 6-wire cable.

NOTE:
The HOXB requires a negative DC voltage; therefore, the main HKSU power cannot be used (it is +24 volts).

06.60 Off-Premise Line Connection

06.61 When using the HOLB unit, CO lines

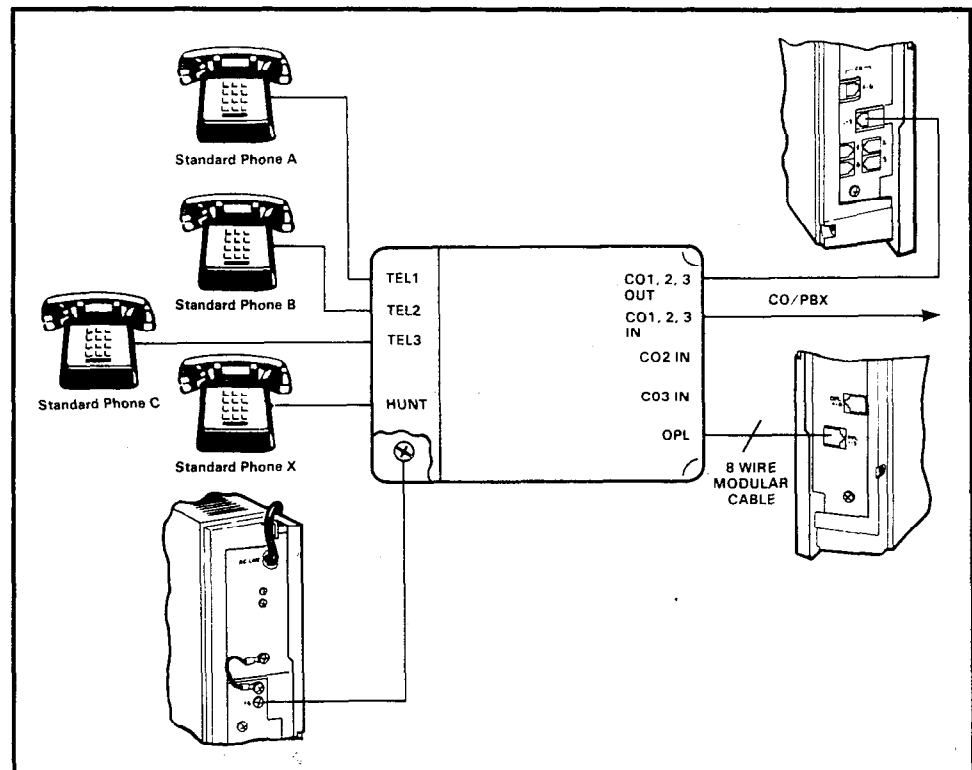

FIGURE 20—HOLB WIRING

INSTALLATION PROCEDURES
SECTION 300-006-200
MAY 1986

1, 2 and 3 (RJ-25C) or 1, 2 or 3 (RJ-11C) are connected to the CO 1, 2, 3 (or CO 1, CO 2 or CO 3) in connectors on the HOLB unit. Then, connect a 6-wire cable from the HOLB to the CO 1-3 connector on the right side panel of the HKSU. An 8-wire factory-provided cable is connected from the HOLB 1-3 connector (on the HKSU left side panel) to the HOLB unit. Connect up to three conventional, single-line telephones to the modular connectors (TEL 1, 2, 3) on the HOLB (Figure 20).

06.62 A similar procedure is followed if a second HOLB unit is to be connected to the HOLB 4-6 connector.

06.63 A single answering machine connected to OPL circuit #1 will also serve OPL circuit #2 and/or #3. An HOLB is equipped with a chain of relay contacts (Figure 20) that, operating under software control via **Program 0#9**, can switch incoming calls on CO circuits #2 and/or #3 to the OPL #1 output circuit. This hunting operates only during NITE service and can occur only with the three circuits appearing on the PCB; and it always occurs from #3 and/or #2 to #1. (It is not possible to chain two HOLB PCBs together.)

06.70 Station Message Detail Recording Connections

06.71 If the system is to be equipped with Station Message Detail Recording (SMDR), an HSMB option module must be connected to the system (via two factory-provided 8-wire cables) from the HSMB's **CONT** and **PW** connectors. Printer types known to be compatible with this system are:

- Texas Instruments Model 743/745
- OKI Data Model 82A

06.72 The data output is in 7-bit ASCII code with one start bit, one parity bit (even parity) and one stop bit. Figure 21 shows the detailed connections for the printers listed above.

06.73 Verify that the RS-232C output cable is connected to the PCB with the proper pin-out connections (A or B), the battery strap is **ON**, and the data speed and incoming/outgoing call options are selected per Paragraph **06.50**.

07 EKT INFORMATION

07.00 General

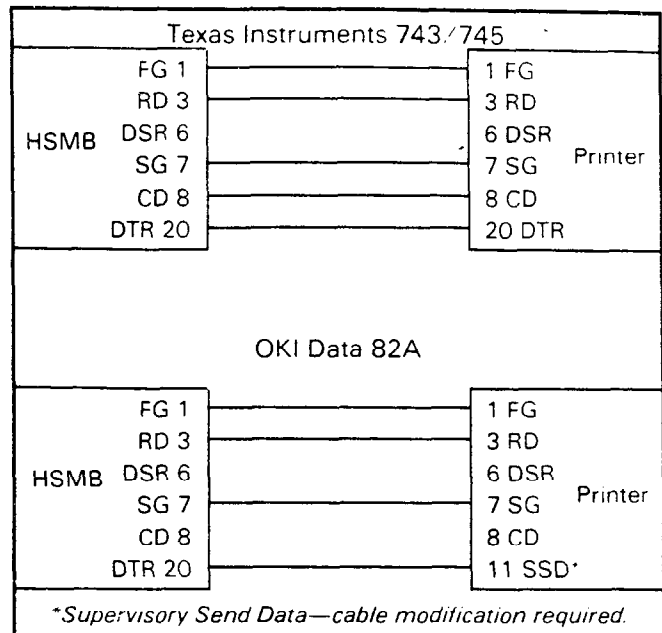

FIGURE 21
HSMB/PRINTER CABLING

07.01 Six different Electronic Key Telephones (EKTs) may be used in the **Strata V1e** system. The 10-key EKT (Figure 22) is available as a speakerphone or with handsfree answerback (HFU) only. The two models, identical in appearance, are equipped with four permanently dedicated keys and 10 line/feature keys. The HFU model may be answered handsfree on intercom calls only. The 10-key BLF EKT with speakerphone (Figure 23) is similar in appearance to the 10-key, but with a Busy Lamp Field (BLF).



FIGURE 22—10-key EKT



FIGURE 23—10-key BLF EKT

07.02 Three additional EKTs that are very similar to the 10-key, but with 10 additional keys, are also available. The 20-key EKT (Figure 24) is available as a speakerphone or with handsfree answerback only. The two models, identical in appearance, are equipped with four permanently dedicated keys and 20 line/feature keys. The HFU model may be answered handsfree on intercom calls only. A 20-key Liquid Crystal Display (LCD) EKT (Figure 25), which has a 32-character alphanumeric display, is also available.

07.03 All EKTs share the same dimensions:

Height: 3.87" (98.5 mm)
Width: 7.0" (178 mm)
Depth: 9.0" (229 mm)



FIGURE 24—20-key EKT



FIGURE 25—20-key LCD EKT

07.04 Each is equipped with either 14 or 24 line/feature keys in addition to a push-button dial pad. Up to six of the keys are utilized for CO/PBX lines: one for intercom access and the remaining keys are used for feature operation. System software assignments permit wide variation to the feature keys on all six EKTs.

07.05 The principal components of the 10-key electronic key telephone are: handset, dial pad, handsfree answerback (HFU) microphone, a microphone control key **MIC**, speaker and **SPKR** key, two ringing/speaker volume controls, one intercom key, nine CO/PBX line or feature keys. LED indicators are provided for all keys except the **HOLD** and **CONF** keys. With the exception of the four permanently dedicated keys, the feature keys can be assigned to any one of several keystrip modes by programming. The identical EKT is also available as a speakerphone.

07.06 The 10-key BLF EKT provides the same features as those listed in Paragraph 07.05, plus an LED indication showing which stations are in use.

07.07 The 20-key EKT provides the same features as those listed in the above two paragraphs, plus 10 additional feature keys.

07.08 A 20-key Liquid Crystal Display (LCD) EKT, incorporating the same features as those listed for the above EKTs, may be located at any or all of the stations. The 32-character alphanumeric display provides an accurate

INSTALLATION PROCEDURES
SECTION 300-006-200
MAY 1986

clock/calendar in its idle state. In use, the display provides elapsed time of call (incoming or outgoing), dialed number, calling station or CO line.

07.09 All EKTs feature modular handset cords and are connected to the system via 4-conductor modular line cords. In addition, each EKT model may be used at any or all stations.

07.10 EKT Wall Mounting

07.11 All EKTs are mounted in the same manner, and they may be mounted on a wall or any other flat, vertical surface to which the base can be secured. When selecting the mounting site, consider the EKT's weight and the additional stresses to which the mounting will be subjected.

07.12 Mounting screws or mollies, appropriate for the surface on which the telephone is to be secured, must be provided by the installer.

07.13 Locking tabs secure the EKT's base. The direction in which the base is attached to the EKT determines whether it will be used as a desk unit or wall unit (it is factory-configured as a desk unit). Disengage the locking tabs by pushing downward on the base (Figure 26), and then rotate the base 180° and insert it into the lower four locking tabs.

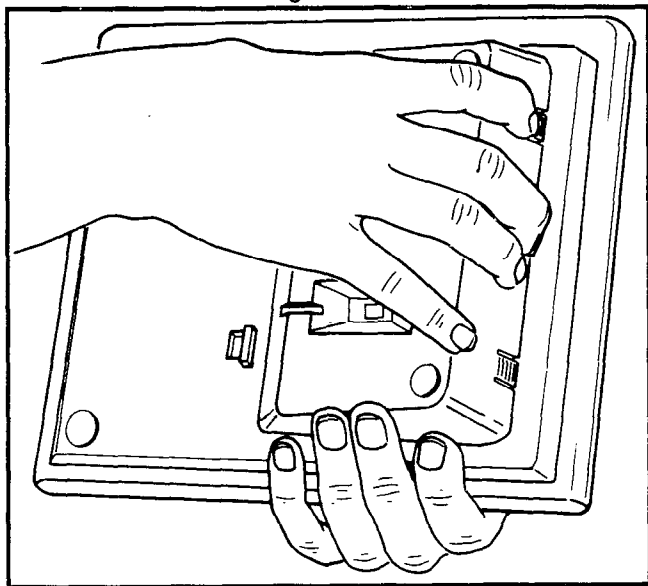

FIGURE 26—REMOVING EKT BASE

07.14 Refer to Figure 27, choose which of the knockouts are appropriate for the tail cord route, and then cut them out.

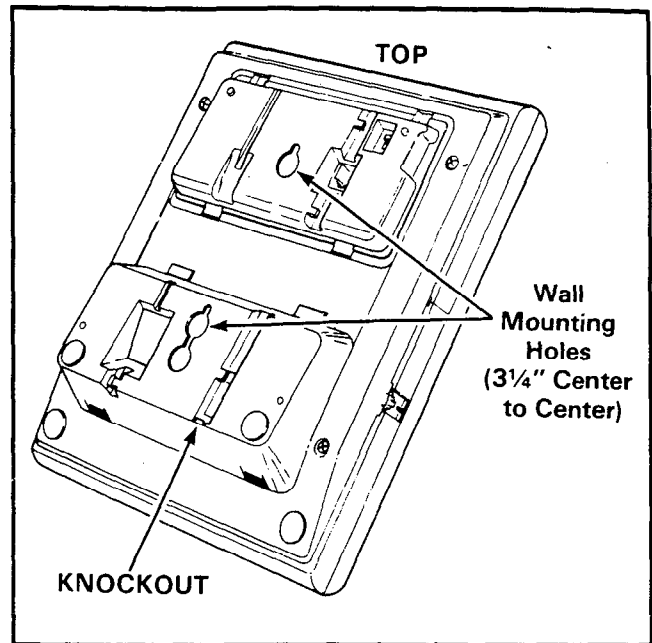

FIGURE 27—EKT WIRE ACCESS

07.15 Secure the unit to the desired wall site. (Use dimensions shown in Figure 27 to position the unit.)

07.16 Route the tail cord through the holes in the base and secure the EKT (Figure 28).

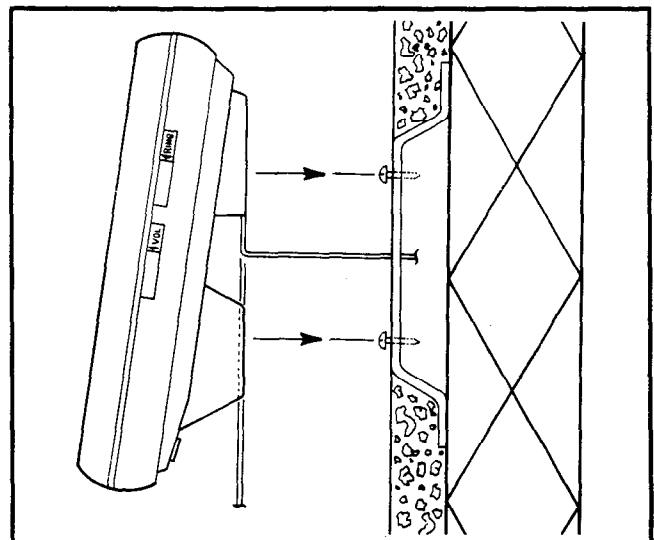

FIGURE 28—EKT WIRE ROUTING

07.17 An optional 13' handset cord is available from your Toshiba supplier, and it is suggested that this cord be used when wall mounting an EKT.

07.18 Remove the handset hanger and insert it in the upper hole as shown in Figure 29. Note that the hanger fits in the notch in the handset.

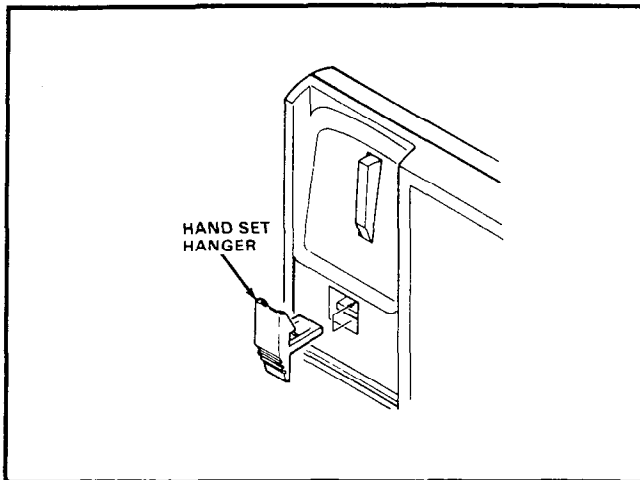

FIGURE 29—HANDSET HANGER

07.20 EKT Connections

07.21 Connect the appropriate length line cord to the modular connector, route the cord to the EKT and connect to the EKT modular jack. Test the EKT per Paragraph 09.

08 SYSTEM POWER-UP INITIALIZE

08.00 General

08.01 *Strata V1e* has a list of standard system data assignments stored in ROM that can be entered at any time by performing the initialize sequence outlined below. The system must be initialized when it is first installed or whenever the VCCU PCB is changed. This will allow the system to be tested and any faults to be corrected before time is spent on programming.

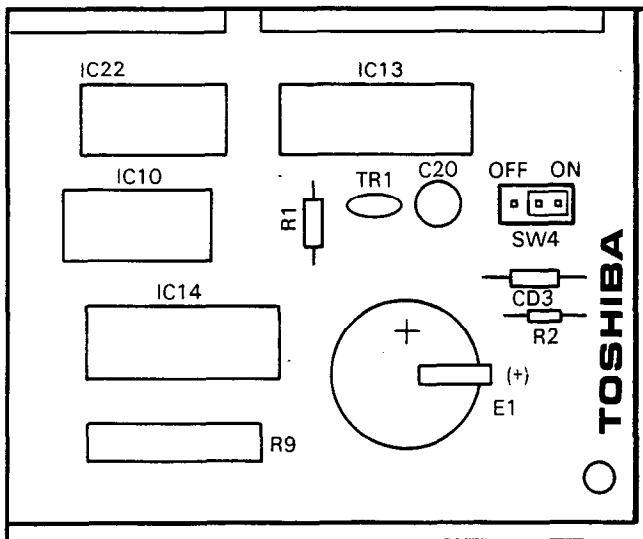

FIGURE 30—VCCU BATTERY STRAP

NOTE:

Do not initialize if using a preprogrammed, battery-protected VCCU.

08.02 Refer to Figure 30 and verify that the battery on the VCCU is connected to ensure that data changes entered after initialization will not be lost due to power failure.

NOTE:

The SET LED will not function if the VCCU battery is not connected.

08.03 To initialize the system data memory, refer to Figure 31 and perform the following:

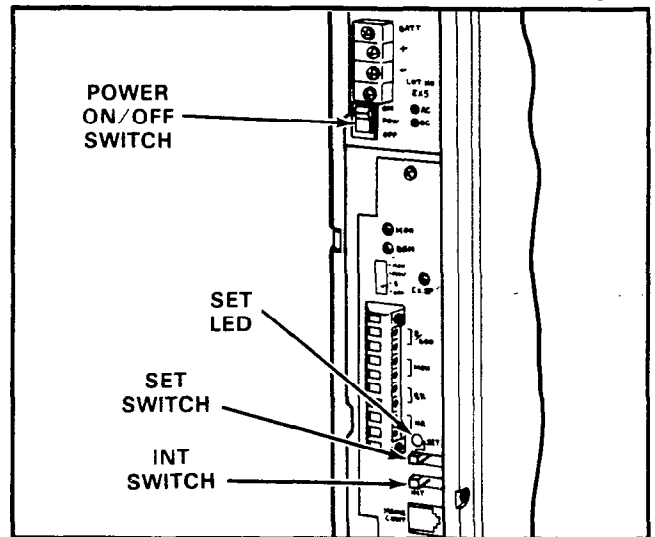

FIGURE 31—INITIALIZE SWITCH

- 1) Place the system power switch (POW) in the ON position.
- 2) Depress the INT switch on the left side panel, and hold it in.
- 3) Depress the SET switch and allow it to lock.
 - SET LED goes on.
 - Station 17: All LEDs except SPKR and MIC flash continuously.
- 4) Depress and release the SET switch again.
 - SET LED goes off.
 - Station 17: All LEDs go off.
- 5) Release the INT switch.
- 6) Cycle the power switch OFF and ON.

08.10 Clearing Automatic Dialing

08.11 The Automatic Dialing memory will contain random numbers when the system is powered up initially. The memory; therefore,

**INSTALLATION PROCEDURES
SECTION 300-006-200
MAY 1986**

must be cleared to prevent meaningless numbers from being dialed.

IMPORTANT!

Station 17 may be equipped with either a 10-key or a 20-key EKT. Prior to performing the procedure that follows, refer to Paragraph 02.20/ Figure 1, Programming Procedures, Section 300-006-300, for instructions on using a 10-key EKT for programming.

08.12 To clear the Automatic Dialing (-System and -Station) memory (up to 40 numbers), proceed as follows:

- 1) Lock in the **SET** switch on the HKSU.
 - Station 17: All LEDs except SPKR and MIC flash continuously.
- 2) Depress the **SPKR** key on station 17.
 - SPKR LED lights steadily.
- 3) Dial **#*#** on the dial pad.
 - SPKR LED flashes continuously.
- 4) Depress the **INT CO4 DND AD3** keys, respectively.
 - The corresponding LEDs light.
- 5) Depress the **HOLD** key.
 - All station 17 LEDs (except REP) go off.
- 6) Release the **SET** switch on the HKSU:

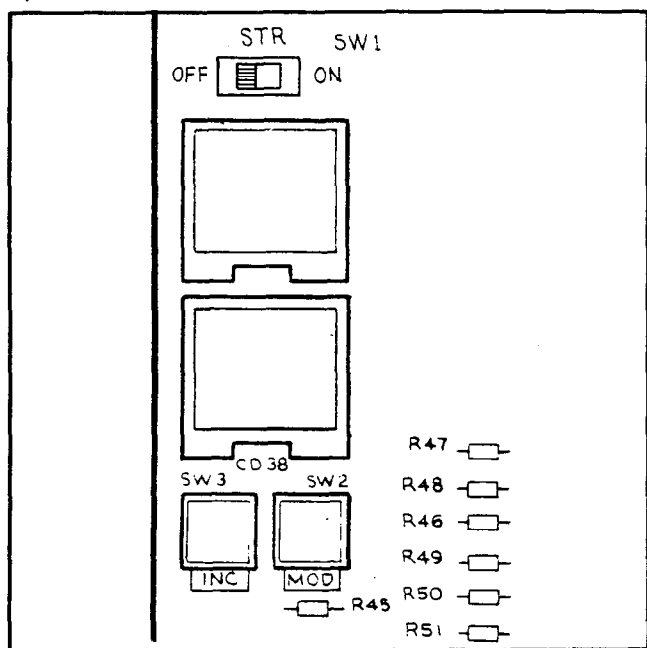

**FIGURE 32
HSM3 SWITCHES and LEDs**

- The SET LED and REP LED on station 17 go off.

08.20 SMDR Real-Time Clock Adjustment

08.21 One of the functions of the HSMB is to provide a calendar and clock for showing time, date and duration of recorded calls. This clock and calendar must be set when the system is first placed into service.

08.22 The HSMB is equipped with a battery to protect the clock and calendar settings in event of a power failure. Ensure that the HSMB battery (**BATT**) strap is in the **ON** position (see Figure 11).

08.23 The HSMB will automatically adjust for 30- and 28-day months and leap year.

08.24 The HSMB is equipped with three switches and two LEDs (Figure 32). Looking from top to bottom, the functions of the switches are as follows:

STR: Writes data into memory once it is properly displayed.

MOD: Selects items to be adjusted. Multiple depressions of the **MOD** switch will cause item numbers to be displayed sequentially by LED #1. The possible displays are:

- Off**
- 1 = year
 - 2 = month
 - 3 = day
 - 4 = hour
 - 5 = minute
 - 6 = start

INC: Selects the data (hour, minute, day, etc.) for the item number selected by the **MOD** switch and displayed by LED #1. LED #2 displays data selected by the **INC** switch.

- Depressing the **INC** switch once increments data by 1.
- Depressing and holding the **INC** switch causes data to increase continuously until the **INC** switch is released.

08.25 To set clock and calendar:

- 1) Verify that the battery is connected on the HSMB (Figure 32).
- 2) Depress the **MOD** switch once.
 - LED #1 displays 1 (year).

- LED #2 displays current data.

3) Use the **INC** switch to correct data in LED #2 display.

4) Depress the **MOD** switch once.

- LED #1 displays 2 (month).
- LED #2 displays current data.

5) Use the **INC** switch to correct data in LED #2 display.

6) Depress the **MOD** switch once.

- LED #1 displays 3 (day).
- LED #2 displays current data.

7) Use the **INC** switch to correct data in LED #2 display.

8) Depress the **MOD** switch once.

- LED #1 displays 4 (hour).
- LED #2 displays current data.

9) Use the **INC** switch to correct data in LED #2 display.

10) Depress the **MOD** switch once.

- LED #1 displays 5 (minute).
- LED #2 displays current data.

11) Use the **INC** switch to correct data in LED #2 display.

12) Depress the **MOD** switch once.

- LED #1 displays 6 (start).
- LED #2 has no display.

13) Slide the **STR** switch to **ON** and then back to **OFF**.

- LEDs go off.
- Data is transferred to working memory and time keeping starts.

NOTE:

If LED #1 is changed to OFF before STR is operated, existing data will not be changed regardless of adjustments made in previous steps.

08.30 Program Listing

08.31 The HSMB has the capability to retrieve current customer data from memory and output it to the SMDR printer.

08.32 See Section 200-006-300, *Programming Procedures* for printout method and format.

09 SYSTEM TEST PROCEDURES

09.00 EKT Functional Check

09.01 In order to verify basic system functions, and confirm the proper functioning of the EKT itself, perform the following test procedures at each station. Begin with the lowest numbered station and continue through all stations.

09.02 With handset on-hook:

a) Depress the **INT** key.

- INT LED: I-use flash.
- SPKR LED: on steady.
- MIC LED: on steady.
- Listen for intercom dial tone via the EKT speaker.

b) Adjust speaker volume with the volume control on the right-hand side of the EKT.

c) Depress the **CO1** key.

- CO 1 LED: I-use flash.
- SPKR & MIC LEDs: on steady.
- Listen for CO/PBX dial tone via the EKT speaker.

d) Dial any digit (**2** - **9**) on the dial pad and dial tone will stop.

e) Depress the **MW/FL** key.

- Listen for circuit break followed by dial tone after approximately 2 seconds.

f) Continue to depress each **CO** key in order on every EKT; the following should occur:

- CO LED: I-use flash.
- SPKR & MIC LEDs: on steady.
- Listen for CO/PBX dial tone via the EKT speaker.

NOTE:

*If no CO/PBX facility is connected to a **CO** key, dial tone will not be heard but the LED is still functional.*

g) When CO testing is complete on each EKT, continue EKT test by depressing the **SPKR** key.

- SPKR & MIC LEDs: off.
- EKT speaker off.

h) Depress the **DND** key.

- DND LED: on.

i) Depress the **DND** key.

- DND LED: off.

INSTALLATION PROCEDURES
SECTION 300-006-200
MAY 1986

- j) Depress the **CO1** key.
- CO 1 LED: I-use flash.
 - SPKR & MIC LEDs: on steady.
 - Listen for CO/PBX dial tone via the EKT speaker.
- k) Depress the **HOLD** key.
- CO 1 LED: I-hold flash.
 - Speaker off (no dial tone).
 - SPKR & MIC LEDs: off.
- l) Depress the **CO1** key.
- CO 1 LED: I-use flash.
 - SPKR & MIC LEDs: on steady.
 - Listen for CO/PBX dial tone via the EKT speaker.
- m) Depress the **CONF** key.
- CO 1 LED: Conference call flash rate.
 - Dial tone continues.
- n) Depress the **CO1** and **SPKR** keys.
- CO 1 LED: off.
 - SPKR & MIC LEDs: off.
 - Dial tone: off.
- o) Call the EKT that is being tested from another station.
- Listen for caller's voice via called EKT's speaker after the single tone signal.
 - Called station's INT LED: I-called flash.
- p) Dial **1** at calling station.
- Tone signalling heard via the called station's speaker.
- q) Adjust tone signalling volume with volume control on the rear left-hand side of the EKT being tested.
- r) Depress the **INT** key.
- INT LED: I-use flash.
 - SPKR & MIC LEDs: on steady.
 - Listen for intercom dial tone via the EKT speaker.
- s) Lift handset.
- SPKR & MIC LEDs: off.
 - Speaker off.
 - Listen for dial tone via handset receiver.
- t) Call another station and talk into the handset transmitter.
- Verify that your voice can be heard via the called EKT's speaker.
- u) Hold down the **SPKR** key, and set the handset back on-hook.
- INT LED: I-use flash.
 - SPKR & MIC LEDs: on steady.
- v) Tap the EKT microphone and verify that the sound can be heard via the called EKT's speaker.
- w) Depress the **MIC** key while tapping the microphone and verify that the sound cannot be heard via called EKT's speaker.
- MIC LED: off while the **MIC** key is depressed.
- x) Depress the **SPKR** key.
- INT LED: off.
 - SPKR & MIC LEDs: off.
- y) Depress the **INT** key.
- INT LED: I-use flash rate.
 - SPKR & MIC LEDs: on steady.
 - Listen for intercom dial tone via the EKT speaker.
- z) Call a busy station.
- Listen for busy tone.
- aa) Depress the **ACB** key.
- Dial tone should be heard for 2 seconds followed by busy tone again.
- bb) Depress the **SPKR** key.
- SPKR & MIC LEDs: off.
 - INT LED: off.
- cc) Depress the **INT** key.
- INT LED: I-use flash rate.
 - SPKR & MIC LEDs: on steady.
 - Listen for intercom dial tone via the EKT speaker.
- dd) Dial **77** to cancel the ACB feature.
- Dial tone should be heard for 2 seconds followed by busy tone.
- ee) Depress the **SPKR** key.
- SPKR & MIC LEDs: off.
 - INT LED: off
- 09.03** This completes the station functional check for the EKTs; repeat the procedure for all EKTs in the system.
- 09.10 Off-Premise Extension/Conventional Telephone Functional Check**
- 09.11** Perform the following test procedures at each Off-Premise Extension/Conventional Telephone (OPX) location:

- a) Lift the OPX handset and listen for intercom dial tone.
- b) Dial the number of another station.
 - Dial tone will stop when the first digit is dialed.
 - Ringing or voice paging will be heard at the called station.
- c) Lift the handset at the called station.
 - Ringing stops.
- d) Verify that a 2-way voice connection exists between the OPX and the called station.
- e) Go on-hook at both stations.
- f) Lift the OPX handset and listen for intercom dial tone.
- g) Dial **9**.
 - An idle line, from the group defined by **Program 09**, will be seized.
 - Listen for CO dial tone.
- h) Dial a test call.
 - Verify that a 2-way voice connection is established.
- i) Flash the hookswitch on the OPX and listen for intercom dial tone.
- j) Dial the number of another station.
 - Dial tone will stop when the first digit is dialed.
 - Ringing or voice page will be heard at the called station.
- k) Lift the handset at the called station.
 - Ringing stops.
- l) Verify that a 2-way voice connection exists between the OPX and the called station.
- m) Flash the hookswitch on the OPX.
- n) Verify that a 3-way conference is established.
- o) Go on-hook at the OPX.
- p) Verify that the CO line and called station are connected.
- q) Go on-hook at the called station.

09.20 OPL Circuit Functional Check

09.21 Perform the following test procedures on each OPL/CO line pair:

- a) Lift the OPL telephone handset and listen for CO dial tone.
 - b) Verify that the corresponding CO line LED lights on the system EKTs.
 - c) Dial a test call from the OPL telephone.
 - Verify that a 2-way voice connection is established.
 - d) Depress the corresponding line key on an EKT.
 - Verify that the privacy feature prevents access.
 - e) Go on-hook at OPL telephone.
 - f) Depress the OPL CO line key on an EKT and listen for CO dial tone.
 - g) Dial a test call from the EKT.
 - Verify that a 2-way voice connection is established.
 - h) Lift the OPL telephone handset.
 - Verify that a 3-way voice connection is established.
 - i) Go on-hook at both stations.
 - j) Make an incoming call to the OPL CO line.
 - Ringing will be heard at the OPL telephone.*
 - Appropriate EKT(s) will ring.
 - Appropriate EKT LED(s) will flash.
- *NOTE:
If OPL hunting is programmed for the line being tested, the call will always ring OPL station #1 if it is idle.*
- k) Lift the OPL telephone handset to answer the call.
 - Ringing stops.
 - EKT LED(s) light steadily.
 - Verify that a 2-way voice connection is established.
 - l) Depress OPL **CO** key on an EKT.
 - Verify that the privacy feature prevents access.
 - m) Go on-hook at the OPL telephone.
 - n) Make another incoming call to the OPL CO line.
 - o) Answer the call using an EKT.
 - Verify that a 2-way voice connection is

**INSTALLATION PROCEDURES
SECTION 300-006-200
MAY 1986**

established.

- p) Lift the OPL telephone handset.
 - Verify that a 3-way voice connection is established.
- q) Go on-hook at both stations.

09.30 SMDR Functional Check

09.31 Perform the following test to verify the proper functioning of the SMDR feature.

- a) Connect the printer to the HSMB.
- b) Set data speed and select type of calls to be recorded per Paragraph 05.14.
- c) Make an outgoing call from any EKT.
- d) Enter an account code as follows:
 - Dial the access code (50).
 - Dial the account code (6 digits).
- e) Hang up after the call has been active for at least 10 seconds (calls of less than 10 seconds duration will not be recorded).
 - The call record will be output to the printer in the format shown in Figure 33.

MM/DD/YY					
01	10	HH:MM	00:30;51		7305000
02	14	HH:MM	00:02;39		8531212 123456
04	18	HH:MM	00:01;37	12135551212	654321
03	15	HH:MM	00:04;51	18002436161	
07	19	HH:MM	00:02;25		2731750

FIGURE 33—SMDR PRINTOUT EXAMPLE (Outgoing Call Record)

MM/DD/YY					
01	10	HH:MM	00:01;13	00;02	
02	14	HH:MM	00:02;30	00;04	
03	11	HH:MM	00:03;36	00;10	654321

FIGURE 34—SMDR PRINTOUT EXAMPLE (Incoming Call Record)

- f) Take the printer "off-line" (DTR signal off).
- g) Make an outgoing call.
- h) Hang up after the call has been active for at least 10 seconds.
 - Call record will not be output.

- i) Put the printer "on-line" (DTR signal on).
 - Call record will be output.
- j) Make an incoming call to the system and delay answering it for several rings.
- k) Answer the call.
- l) Enter an account code as in Step d.
- m) Hang up.
 - Call record will be output to the printer in the format shown in Figure 34.

09.40 Feature Check

09.41 Verify that all system features function properly per Section 200-006-400, *Operating Procedures*.

10 MISCELLANEOUS EQUIPMENT CONNECTIONS

10.00 Wiring Connections

10.01 All connections to miscellaneous equipment are made via the barrier strip mounted on the left side panel as shown in Figure 35.

10.10 MOH/BGM Source

10.11 Connect the customer-provided MOH/BGM program source (tuner, tape deck or commercial source) via the two MOH terminals on the barrier strip. Input impedance is 600 ohms.

10.20 Music-On-Hold Volume Control

10.21 Adjust the MOH volume with the MOH volume

control on the left side panel. Maximum volume is limited by internal circuits in order to comply with FCC regulations. See Paragraph 10.80 for the correct volume setting sequence.

10.30 External Paging Connections

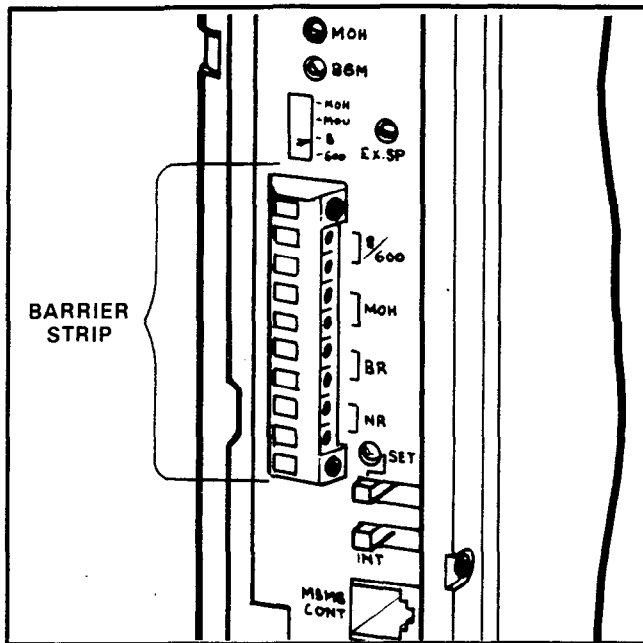

FIGURE 35—TERMINAL STRIP

10.31 *Strata Vle* provides access to an external paging system by dialing two digits (89). The single output connection is made via the 8/600 terminals on the left side panel, and can be used in one of three ways:

- a) To operate customer-provided speaker directly via an internal 3-watt amplifier located on the SEPU PCB.
- b) If more than 3 watts are required, an external customer-provided amplifier can be connected to operate the external speaker.
- c) If talkback capability is required, a customer-provided talkback amplifier/speaker can be connected.

NOTE:

See Paragraph 10.80 for the correct volume setting sequence.

10.40 Direct External Speaker Connection

10.41 The exact number of speakers that may be connected to the 8-ohm, 3-watt output will depend on type of speaker used, conductor resistance and desired volume.

10.42 The 8-ohm output impedance must be selected with the **SW2** switch on the left side panel (Figure 36). The switch must be on the side labeled "8".

10.43 Connect the external speaker to the

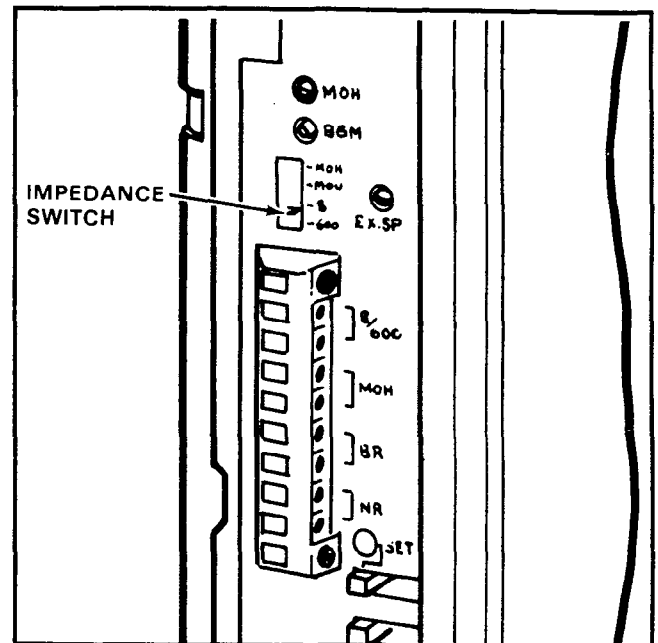

FIGURE 36—IMPEDANCE SWITCH

two 8/600 terminals on the left side panel connector block.

10.44 Adjust the speaker volume with the **EX.SP** volume control on the left side panel.

10.50 External Amplifier Connection

10.51 If more power is required than the SEPU amplifier can deliver, a customer-provided external amplifier may be connected to the 8/600 terminals on the left side panel (connect external speakers to the external amplifier).

10.52 Determine which output impedance is most suitable for the amplifier being used, and make the selection with the **SW2** switch on the left side panel.

10.53 If 8-ohm impedance is chosen, the **EX.SP** volume control may be used to the control input level to the external amplifier. If 600-ohm impedance is chosen, the level is fixed and input must be controlled by the external amplifier. See Paragraph 10.80 for the correct volume setting sequence.

10.60 Talkback Amplifier

10.61 A customer-provided talkback amplifier/speaker may be connected to the external page (8/600) terminals on the left side panel.

10.62 For talkback operation, the **SW2**

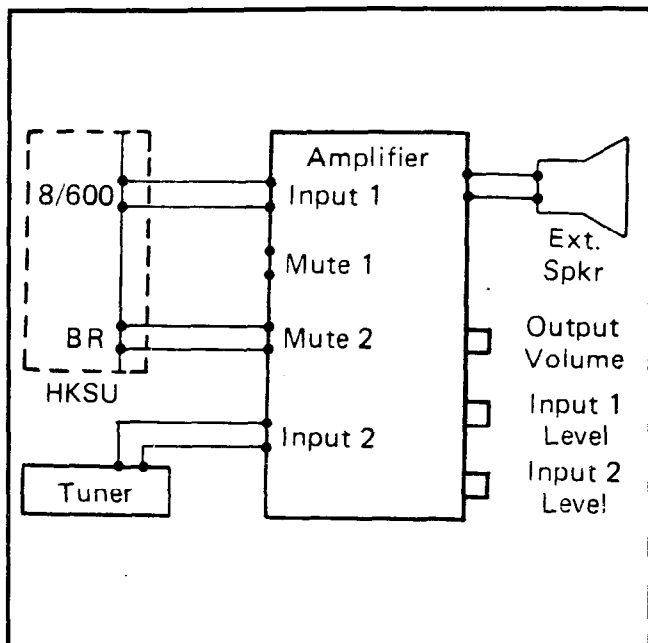

FIGURE 37

EXTERNAL AMPLIFIER HOOK-UP

switch must be set at "600". The SMOU amplifier is not used for the 600-ohm mode in order to permit a 2-way voice path.

10.63 The EX.SP volume control on the left side panel will not function when the 600-ohm mode is selected.

10.70 Background Music

10.71 BGM uses the music-on-hold program source that is connected to the MOH input terminals on the left side panel or the internal MOH source (SMOU). It is broadcast through all EKT speakers (under the individual control of each station user) and will be heard if the **SPKR** key is operated with the handset on-hook and no line selected.

10.72 As a programmable option, BGM from the MOH source can be heard via the external speaker (see Section 200-006-300, *Programming Procedures*).

10.73 BGM is automatically pre-empted when a page or ringing signal must be output from an EKT speaker or the external speaker.

10.74 Overall system BGM volume is set with the **BGM** volume control on the left side panel of the HKSU (see Paragraph 10.80 for the correct volume setting sequence). The volume at individual stations is set with volume

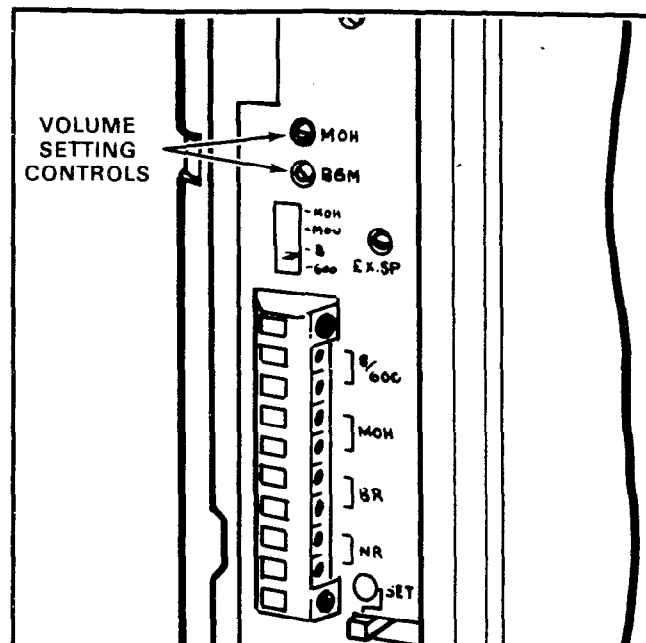

FIGURE 38

VOLUME SETTING CONTROLS

control on the right-hand side of the EKTs.

10.75 If a separate BGM source is connected via an external amplifier on the external amplifier/speaker only. If required, **Strata V1e** can provide a dry contact control signal for muting the external BGM when a page is in progress.

10.76 To provide external BGM control, connect the BR terminals on the left side panel of the HKSU to the control terminals (mute, MIC switch, etc.) on the amplifier (see Figure 37).

10.80 Volume Setting Sequence

10.81 Refer to Figure 38 and adjust the volume for MOH, BGM and External Page in the sequence outlined in Paragraph 10.82.

10.82 Adjust the MOH level first according to the following procedures:

- 1) Set the **MOH** volume control to its lowest level (counterclockwise).
- 2) Lift the handset on one station and call another station using two CO/PBX lines.
- 3) At the called station, put the incoming call on hold, and listen on the handset (not the speaker) of the calling EKT.

4) Using the volume control on the MOH source, adjust MOH to the most comfortable level without distortion.

5) If a higher level is needed than can be provided by the MOH source, turn the MOH volume control slowly clockwise to achieve the most comfortable level without distortion.

6) Release the connection between the two CO lines.

7) No further changes should be made using the MOH control or the MOH source volume control.

10.83 If an external speaker is to be used in the system; adjust the external page and BGM levels as follows:

1) Adjustments should be made while an actual external page test is in progress. Adjust the voice volume to a comfortable level. The procedure varies depending on the paging system configuration and the setting of the 8/600-ohm switch (SW2):

a) 8 ohms with no external amplifier—adjust output level using the EX.SP volume control on the left side panel.

b) 8 ohms with external amplifier—adjust output level using the EX.SP volume control along with the controls on the external amplifier.

c) 600 ohms—the volume level through **Strata V1e** is fixed in this mode; adjustments must be made using the external amplifier controls.

2) If background music is to be heard over the external speaker:

a) Adjust voice page level per above procedures.

b) With music playing over the speaker, adjust the volume to a comfortable level using only the BGM control on the left side panel of the HKSU. Do not tamper with the EX.SP control, external amplifier or MOH adjustments.

c) If background music is connected directly to the external amplifier instead of through the system, all adjustments must be made on the external amplifier.

10.84 If no external speaker is to be used in the system, adjust the BGM level as follows:

1) Using an EKT in speakerphone mode, make

a call on a CO line, and adjust the EKT speaker volume to a comfortable level.

NOTE:

This should be done in an area that has background noise that is about average for that particular installation.

2) Using the **SPKR** key, disconnect the CO call and activate BGM at the EKT.

3) Using only the **BGM** volume control, adjust the BGM to a comfortable level. Do not use the EKT volume control.

10.90 Night Relay Service

10.91 As an option, **Strata V1e** can provide a dry contact for the purpose of controlling an external loud ringing bell (or similar device) or an answering machine when the system is in the "NITE" mode.

10.92 To provide this service, connect the external device to the NR contacts on the left side panel (see Figure 39).

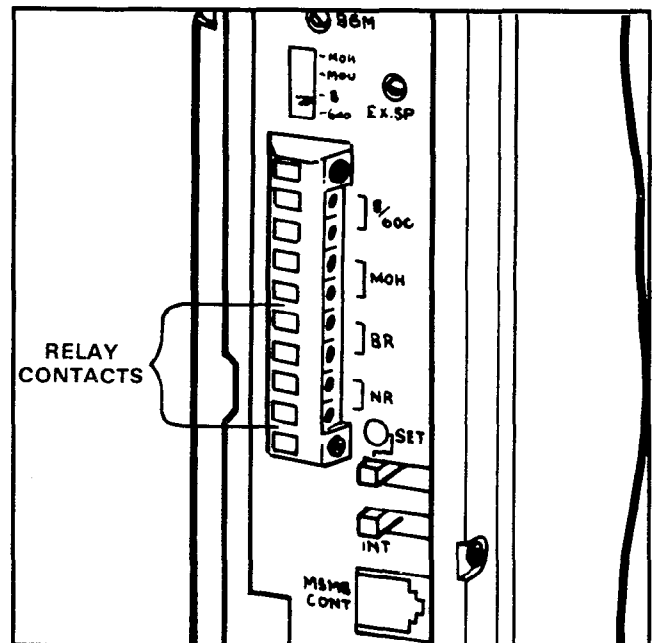

FIGURE 39—RELAY CONTACTS

IMPORTANT!

The NR and BR relay contacts are rated at 24 VDC/1 amp and are not intended to operate high power devices directly. If the power required for the device being controlled exceeds the contact ratings, an external slave relay must be used.

INSTALLATION PROCEDURES
SECTION 300-006-200
MAY 1986

10.93 The **W3** strap option on the VMAU allows the NR relay to function in one of two modes:

a) Answering Machine Control—if the **W3** strap remains intact, the relay is operated continuously when the system is in Night Service. This mode is intended for indirect control of an answering machine.

b) Night Bell Control—if the **W3** strap is cut, the relay pulses at a 1-second on, 3-second off rate when the system is in Night Service and an incoming call is ringing the system. The mode is intended to be used for indirect control of an external night bell.

TOSHIBA SYSTEM PRACTICES
ELECTRONIC KEY TELEPHONE SYSTEM

PROGRAMMING PROCEDURES
SECTION 300-006-300
MAY 1986

Strata VI_e

PROGRAMMING PROCEDURES

DSS Feature Key Programming

On the STRATA VI_e, XII_e & XX_e systems, a maximum of two keys may be programmed as DSS1 and DSS2 on each station. The **DSS1** and **DSS2** keys function as both Direct Station Selection (DSS) and Busy Lamp Field (BLF) feature keys.

It is recommended that a maximum of four DSS keys be directed to one station (Program **4#XX**). Example: Stations 13, 22, 15 and 12 all have DSS keys directed to station 16. All DSS and BLF features operate.

However, if more than four DSS keys are directed to the same station, the fifth and all succeeding keys will not function as a BLF when the target station is busy. This does not affect the Direct Station Selection feature (the station will still be selected when the appropriate DSS key is depressed). Example: Stations 13, 22, 15, 12 and 19 all have DSS keys directed to station 16. The DSS and BLF features operate for stations 13, 22, 15 and 12, but station 19 only has the DSS feature, *not* the BLF feature.

Strata VI_e

PROGRAMMING PROCEDURES

TABLE of CONTENTS

PARAGRAPH	SUBJECT	PAGE
	TABLE of CONTENTS	i
	ILLUSTRATION LIST	i
	TABLE LIST	ii
01	INTRODUCTION	1
02	PROGRAMMING PROCEDURES	1
02.00	General	1
02.10	Multiple Station Programming	2
02.20	Using 10-key EKT for Programming	2
02.30	Preparation	3
02.40	System Options	3
02.50	CO Line Options	5
02.60	Station Options	8
02.70	Initialization	11
02.80	System Data Entry	12

ILLUSTRATION LIST

FIGURE	TITLE	PAGE
1	10-key EKT Key Format	2
2	Feature Key Assignments	9

Strata V_e

PROGRAMMING PROCEDURES

TABLE LIST

TABLE	TITLE	PAGE
1	Hold Recall Time Code	10
2	Initialized Data	12
3	Program 01 —System Assignments (Basic)	16
4	Program 02 —System Assignments (Options)	17
5	Program 0#2 —Account Code Digit Length	18
6	Program 03 —System Assignments (Options)	19
7	Program 04 —VCOU MF/DP Outpulsing Selection	20
8	Program 05 —Automatic Recall From Hold Timing	21
9	Program 0#5 —Camp-on Timeout	22
10	Program 06 —AROH Enable	23
11	Program 07 —AROH Timing	24
12	Program 0#8 —Night Ring Over External Page	25
13	Program 09 —Single CO Line (Dial 9) Group Selection	26
14	Program 09X —Four CO Line Group Selection	27
15	Program 0#9 —OPL Line Hunting	28
16	Program 100 —Toll Restriction System Parameters	29
17	Program 101 —Toll Restriction Disable	30
18	Program 102 —Forced Account Code Check	31
19	Program 103 —Equal Access or Other Common Carrier (OCC) #1	32
20	Program 104 —OCC Authorization Code #1	33
21	Program 105 —Equal Access or Other Common Carrier #2	34
22	Program 106 —OCC Authorization Code #2	35
23	Program 1X0 —Toll Restriction Class Parameters	36
24	Program 1XY —Toll Restriction Class—Area Code	37
25	Program 1XZ —Toll Restriction Class—Office Code	38
26	Program 1X1 —Toll Rest. Class (AOC) Exception Table Selection	39
27	Program 2XY —Area/Office Code Exception	40
28	Program 190 —PBX Back-up	41
29	Program 19X —PBX Access Codes	42
30	Program 3XX —Station CO Line Access	43
31	Program 4XX —Station Type Assignment	44
32	Program 4#XX —Station Flexible Key Assignment	45
33	Program 5XX —Station Class of Service #1	46
34	Program 5#XX —Station Class of Service #2	47
35	Program 6XX —Toll Restriction Classification	48
36	Program 7XX —Station Outgoing Call Restriction	49
37	Program 8XX —CO Ringing Assignments—DAY	50
38	Program 8#XX —CO Ringing Assignments—DAY 2	51
39	Program 9XX —CO Ringing Assignments—NITE	52

01 INTRODUCTION

01.01 The data governing overall system operation and feature execution for the **Strata VIe** system is stored in read-only-memory (ROM) and cannot be altered in the field. However, the data controlling operation of the various options, both system and station, is stored in random-access-memory (RAM) and can easily be changed according to individual installation requirements.

01.02 All **Strata** options are controlled by selections made in the system data tables. An initialization process is provided for verifying predetermined system assignments. The installer can then proceed with any necessary changes.

01.03 All system data changes are made via station 17 (as the input-output device), which may be equipped with either a 10-key or a 20-key EKT. Whenever the system is placed in the programming mode, the keys on station 17 are used to enter data while its LEDs display the current data. While station 17 is in the programming mode, the remainder of the system may still be used in the usual fashion.

01.04 Internal battery power is provided to prevent loss of system data memory in the event of a power failure.

NOTE:

Whenever a system is installed for the first time or the VCCU is changed, the system must be initialized. See Paragraph 02.70.

02 PROGRAMMING PROCEDURES

02.00 General

02.01 The **Strata** system must be in the programming mode before system data can be verified or altered. With the exception of station 17, normal system functions are not suspended while in the programming mode.

02.02 When the system is in the programming mode, station 17 is used to enter the system data in one of two ways:

IMPORTANT!

Station 17 may be equipped with either a 10-key or a 20-key EKT (a 20-key LCD EKT is recommended). In all tables and

procedures that follow, a single key designation is given.

- In the majority of programs (Type 1), the various keys are used to change "bits" of system data. The LEDs associated with the keys show the status of that "bit" before and after key depression. A particular key and LED will have a different meaning, depending upon the program number being used.
- In Type 2 programs, the dial pad is used to enter data. In this case, the system, using the INT and selected CO and AD LEDs, verifies the entered data by displaying it in binary format. An LCD EKT also displays the data, if equipped.

02.03 The programming mode is activated by locking in the **SET** switch on the left side panel of the HKSU and then depressing the **SPKR** key on station 17. After the station has been activated, a program number is dialed on the station dial pad, and the system will respond as follows:

Type 1 programs: Station 17 LEDs will display the existing data in these categories.

Type 2 programs: AD 1 LED on station 17 will flash continuously. Actual data can be reviewed without alteration by multiple depressions of the **#** key.

02.04 Data can be altered while it is being displayed. To input new data via station 17, perform the following:

Type 1 program: The state of an LED is altered by depressing its associated key. Depressing the key while the LED is "on" will turn it off and vice versa.

Type 2 program: Data is entered via the dial pad. The LEDs will display the data in binary format. An LCD EKT also displays the data, if equipped.

02.05 Once the desired data is entered and displayed, it is written into memory by depressing the **HOLD** key on station 17.

- System and CO line options are written into temporary storage when the **HOLD** key is depressed. After all changes in these categories have been made, transfer the data

PROGRAMMING PROCEDURES
SECTION 300-006-300
MAY 1986

into working memory per Paragraph 02.06.

- Station option data (with the exception of CO line access assignments) are written into the main data memory; therefore, all changes are effective immediately after the **HOLD** key is depressed. However, it is recommended that the data transfer procedures per Paragraph 02.06 be utilized for added programming protection.

02.06 Data may be secured in working memory in one of two ways:

1) If the system is not in service, release the **SET** switch on the left side panel of the HKSU, and cycle (rock) the system power switch off and on to transfer all data into the main data memory. Note: all calls are dropped when this occurs.

2) If the system is in service and no calls should be dropped, depress the following keys, in the order given here, on station 17: **SPKR # * 9 INT CO1 CO4 CO5 DND MW/FL AD3 AD4 HOLD**. This code will secure the data in working memory without cancelling any calls. Release the **SET** switch.

02.10 Multiple Station Programming

02.11 Programs **3XX** through **9XX** are used to select options for individual stations (where XX represents the station number of the station being programmed). To save time, it is possible to program all stations or groups of stations simultaneously.

02.12 Multiple station programming is accomplished by substituting a special group code for the station number part of the program number (XX). The codes are:

- 00**: All stations
- 01**: Stations 10 - 17
- 02**: Stations 18 - 25

02.13 When the multiple station group code is entered, the LEDs will display existing data as follows:

Steady LED: Data is the same for all stations in dialed group.

Flashing LED: Data is selected for at least one, but not all stations in that group.

02.14 The state of an LED is altered by de-

pressing its associated key. LEDs that are flashing can be cycled through three states (flashing, on, off) by multiple key depressions. Other LEDs will cycle between on and off states only. Select data as follows:

LED ON: Selects LED "ON" for all stations in the group.

LED OFF: Selects LED "OFF" for all stations in the group.

LED flash: No change to any station in the group.

02.15 Once the proper data is selected, depress the **HOLD** key in the usual manner to write it into memory.

02.20 Using 10-key EKT for Programming

02.21 If station 17 is equipped with a 10-key EKT, the system must be so informed by setting the ACB LED to "ON" in **Program 01**. This change is effective immediately after the **HOLD** key is depressed, making it easy to switch between EKT types.

02.22 Once the system recognizes a 10-key EKT, the handset hookswitch can be used as a shift signal to make the 10-key LEDs compatible with the 20-key programming format.

02.23 As shown in Figure 1, the key/LEDs on a 10-key EKT represent INT, CO1 - CO6, ACB, DND and MW/FL when the handset is on-hook and AD1 - AD7, PAU, RDL and REP when the handset is off-hook. It is possible to switch back and forth an unlimited number of times without disturbing the data.

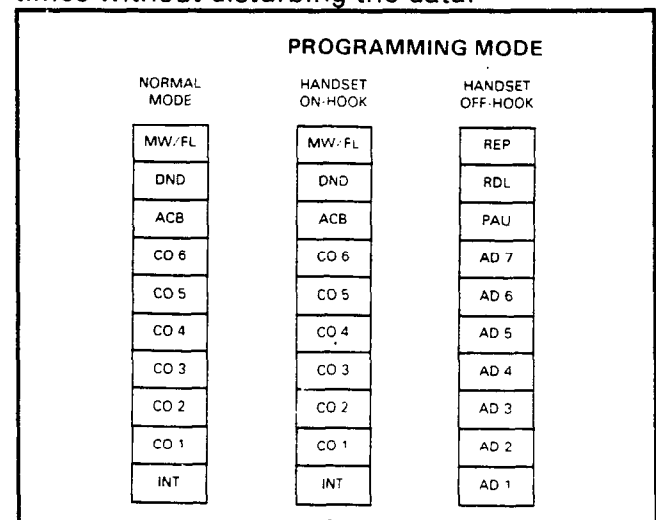

FIGURE 1—10-key EKT KEY FORMAT

NOTE:

This procedure is for programming purposes only! For normal operation, the station 17 EKT type must be set using Program 4XX.

02.24 In all procedures that follow, a single key designation is given if it is the same for both EKT types. If a difference exists, the matching 10- and 20-key designations are given first and the upper 10-key designations (off-hook) are then indicated inside brackets.

02.30 Preparation

02.31 Before **Strata** system data can be programmed, option selections must be made and then indicated on the System Record Sheet (shown in Appendix 1). The Record Sheet, one of which accompanies each HKSU, will then serve as a programming guide and installation record.

02.32 Programming options are grouped according to the three categories listed below, with several program numbers associated with each category. A different program number is used for each option or group of options being selected.

A) System Options

- 01: System Assignments (Basic)
- 02: System Assignments (Options)
- 0#2: Account Code Digit Length
- 03: System Assignments (Options)
- 04: VCOU Output Selection
- 05: Automatic Recall From Hold Timing
- 0#5: Camp-on Timeout

B) CO Line Options

- 06: Automatic Release On Hold (AROH) Enable
- 07: Automatic Release On Hold Timing
- 0#8: Night Ring Over External Page
- 09: Single CO (Dial 9) Group Selection
- 09X: Four CO Line (Dial 91, 92, 93, 94) Groups Selection
- 0#9: OPL Line Hunting
- 100: Toll Restriction System Parameters
- 101: Toll Restriction Disable
- 102: Forced Account Code Check
- 103: Other Common Carrier (OCC) or Equal Access #1
- 104: OCC Authorization Code Length #1
- 105: Other Common Carrier or Equal Access #2

- 106: OCC Authorization Code Length #2
- 1X0: Toll Restriction Class Parameters
- 1XY: Toll Restriction Class—Area Code
- 1XZ: Toll Restriction Class—Office Code
- 1X1: Toll Restriction Exception Codes
- 2XY: Area/Office Code Exception
- 190: PBX Backup
- 19X: PBX Access Codes

C) Station Options

- 3XX: Station CO Line Access
- 4XX: Station Type Assignment
- 4#XX: Station Flexible Key Assignment
- 5XX: Station Class of Service #1
- 5#XX: Station Class of Service #2
- 6XX: Station Toll Restriction Class
- 7XX: Station Outgoing Call Restriction
- 8XX: CO Ringing Assignment-DAY
- 8#XX: CO Ringing Assignment-DAY 2
- 9XX: CO Ringing Assignment-NITE

02.33 The System Record Sheet is used to record the assignment of each key/LED for any given program number. For Type 1 programs, an "X" placed in the record indicates that the associated LED should be turned on (lit) during the programming process. For Type 2 programs, the actual data is recorded.

02.34 After making the system option selections per the following instructions, record the various choices in the System Record Sheet. Use tables 4 through 40 for detailed programming instructions.

02.40 System Options:

01 Program—System Assignments (Basic)

Fourteen options are selected with this program, using the various keys to change the status of their respective LEDs. For the options selected, mark an X as indicated.

1) Transfer Privacy—mark an X next to PAU if privacy is to be in effect on a transferred call. Leave blank if Alternate Point Answer of a transferred call is to be permitted.

2) Automatic Dial Override Toll Restriction—mark an X next to AD7 if addresses 60 - 99 of the System Automatic Dialing are to be allowed to override Toll Restriction. Leave blank if Toll Restriction is to remain in effect.

3) CO Line Groups—mark an X next to AD6 if

PROGRAMMING PROCEDURES
SECTION 300-006-300
MAY 1986

four CO line groups (dial 91, 92, 93, and 94) are required. Leave blank if one group (dial 9) is sufficient.

4) Two CO Line Conference—mark an X next to AD5 to inhibit two CO line conference. Leave blank if two CO line conferencing is to be permitted.

5) DP Make Ratio—mark an X next to AD3 if a 33% make/break timing ratio is required. Leave blank if 40% is sufficient.

6) MF Signal Time—mark an X next to AD2 if 160 ms MF signal time is required. Leave blank if signal time is to remain 80 ms.

7) Non-Privacy/Privacy—mark an X next to MW/FL if the system is to be non-private. Leave blank if the system is to be private.

8) Station 17 10/20-key EKT—mark an X next to ACB if station 17 is equipped with a 10-key EKT for programming purposes. Leave blank if a 20-key EKT is used.

9) Incoming Call Abandon Timeout—mark an X next to CO6 if the system should wait for 8 seconds after the last ring to consider an incoming call abandoned. Leave blank if 6 seconds is sufficient.

10) Pause Timing (After Flash)—mark an X next to CO5 if a 3-second pause (for dial tone delay) is required after a FLASH. Leave blank if a 1 1/2-second pause is sufficient.

11) Pause After Flash—mark an X next to CO4 if the system is to insert a pause (defined by CO5, this program) between a flash and an automatically dialed number.

12) Pause Timing (MW/FL or PAU key)—mark an X next to CO3 if a 3-second pause (for dial tone delay) is required after a PBX/CO access code is dialed by the Automatic Dialing feature. Leave blank if a 1 1/2-second pause is sufficient.

13) Flash Time—mark an X next to CO2 if the line-open interval produced by the MW/FL key is to be 1/2-second for behind PBX operation. Leave blank if the 2-second pause for dial tone recall is required.

14) Tone First—mark an X next to INT if Tone First intercom signalling is required. Leave blank if Voice First signalling is required.

02 Program—System Assignments (Options)

Five options are selected with this program, using the **DND** **CO4** **CO2** **CO1** **INT** keys to change the status of their respective LEDs. For the options selected, mark an X as indicated.

1) Station 21 OPX Busy Out—mark an X next to DND if the system is to "Busy Out" station 21 (not installed). Leave blank if the station is not to present a busy signal. (Has no meaning if an HOXB is not installed.)

2) LCD Timer—mark an X next to CO4 if the Dialed Number display on each LCD EKT is indicated for 1 minute before changing to Elapsed Time. Leave blank if 15 seconds are sufficient.

3) Nite Ring Over External Page—mark an X next to CO2 if Nite Ringing Over External Page is required.

4) Background Music Over External Page—mark an X next to CO1 if BGM is to be heard over the External Page circuit.

5) External Page with All Call—mark an X next to INT if the External Page circuit is to be included in an All Call Page.

0#2 Program—Account Code Length

Defines the number of digits required in an account code (Forced Account Code feature). Enter the number of digits to be used. See the detailed programming chart for account code entry procedures.

03 Program—System Assignment (Options)

Thirteen options are selected with this program using the various keys to change the status of their respective LEDs. For the options selected, mark an X as indicated.

1) Door Lock Timeout—mark an X next to PAU if the door lock is to operate for 6 seconds. Leave blank if 3 seconds is sufficient.

2) Door Phone C Alarm—mark an X next to AD7 if door phone C is to be a door alarm. Leave blank if it is to be a door phone.

3) Door Phone B Lock—mark an X next to AD6 if door phone B is to be a door lock. Leave blank if it is to be a door phone.

4) Door Phone C Busy—mark an X next to

AD5 if the system is to busy out door phone C. Leave blank if it is not to show busy.

5) Door Phone B Busy—mark an X next to AD4 if the system is to busy out door phone B. Leave blank if it is not to show busy.

6) Station 14 Door Phone/EKT—mark an X next to AD3 if station 14 is to be a door phone output. Leave blank if an EKT is to be used at this station.

7) Station 13 Door Phone/EKT—mark an X next to AD2 if station 13 is to be a door phone output. Leave blank if an EKT is to be used at this station.

8) Station 10 **ALRM** Key—mark an X next to AD1 if AD1 key on station 10 is to be an alarm key. Leave blank if **AD1** key is required.

9) Station 10 **DND/NITE** Key—mark an X next to MW/FL if **DND** key on station 10 is to be a **DND** key. Leave blank if **NT** key is required.

10) Nite Ringing Modes—mark an X next to DND if three ringing modes are used. Leave blank if two ringing modes are required.

11) Message Center-Station 12—mark an X next to CO4 if station 12 is to be the message center.

12) Message Center-Station 11—mark an X next to CO3 if station 11 is to be the message center.

13) Message Center-Station 10—mark an X next to CO2 if station 10 is to be the message center.

NOTE:

Only one message center is permitted; if more than one station is chosen as a message center, the lowest numbered station will have priority.

04 Program—VCOU Outpulsing Selection

Selects DTMF tone (MF) or rotary dial pulse (DP) outpulsing.

- Mark an X next to appropriate CO line if DP is required. Leave blank if MF is required.

05 Program—Automatic Recall from Hold Timing

Sets the timing for the Automatic Recall

from Hold feature. (Used only if AD3, AD1 and AD2 LEDs are OFF in Program 5#XX.)

1) If recall is desired, select a time period of 16 - 160 seconds and mark an X next to the appropriate key/LED in the System Record Sheet. The times are not accumulative—only one key/LED can be selected.

2) If no recall is required, mark an X next to INT.

0#5 Program—Camp-on Timeout

Sets the timing for the originating station to be recalled by a CO line that was transferred to a busy station and remains unanswered.

- Select a period of time (16 - 64 seconds) and mark an X next to the appropriate key/LED on the System Record Sheet. The times are not accumulative—only one key/LED can be selected.

02.50 CO Line Options:

06 Program—Automatic Release on Hold Enable

Selects whether or not the Automatic Release on Hold (AROH) feature is to function on a given CO line; the CO line keys represent themselves.

- Mark an X next to each CO line that requires AROH.

07 Program—Automatic Release on Hold Timing

Selects Cross Bar (XB) or ESS timing for the AROH feature using each CO line key to represent itself. (Has no meaning if AROH was rejected in Program 06.)

- Mark an X next to each CO line that requires XB timing; leave blank if ESS timing is required.

0#8 Program—Night Ring Over External Page

Selects whether or not a CO line will ring over external page. (Has no meaning if CO2 LED is not ON in Program 02.)

- Mark an X next to the CO lines that will ring over external page.

09 Program—Single CO (Dial 9) Group

PROGRAMMING PROCEDURES
SECTION 300-006-300
MAY 1986

Selection (OPX, Trunk Queuing)

Informs the system of the CO lines that should be considered for selection when a station dials 9. Each CO key represents itself. (Used only if the AD6 LED in Program 01 is OFF.)

- Mark an X next to each CO key that is to be included in the "Dial 9" group.

09X Program—Four CO Line (Dial 91, 92, 93, 94) Groups Selection (OPX, Trunk Queuing)

Informs the system of the CO lines that should be considered for selection when a station dials 91, 92, 93 or 94. Each CO key/LED represents itself. (Used only if the AD6 LED in Program 01 is ON.)

- 1) Mark an X next to each CO key/LED that is to be included in the 91 group.
- 2) Mark an X next to each CO key/LED that is to be included in the 92 group.
- 3) Mark an X next to each CO key/LED that is to be included in the 93 group.
- 4) Mark an X next to each CO key/LED that is to be included in the 94 group.

0#9 Program—OPL Line Hunting

Selects which lines will hunt in order to ring the lowest station in a group of three stations whenever an incoming call rings. The lines must function in the same groups of three in which they appear in the HOLB. Lines selected will hunt to the lowest numbered line in their groups (3 and 2 hunt to #1, 6 and 5 hunt to #4).

- Mark an X next to each CO key/LED that is to be included in a hunt group. (The lowest number in each group of three must be selected.)

100 Program—Toll Restriction System Parameters (Dialing Plan)

An entry in this program is required only if 3- or 6-digit toll restriction is desired. Informs the system of the dialing plan used. Three types of dialing plans are available. Mark an X next to the LED that describes the dialing plan area of the installation location.

INT: NO/1X + NNX (long distance dialing outside home area code)
1 + NNX (toll dialing within home area code)

CO1: 1 + NO/1X + NNX (long distance dialing outside home area code)
1 + NNX (toll dialing within home area code)

CO2*: 1 + NO/1X + NXX (long distance dialing outside home area code)
NXX (toll dialing within home area code)

N = 2 - 9
0/1 = 0 or 1
X = 0 - 9

***NOTE:**

This dialing plan is required when the dialing plan area code has interchangeable office codes (NXX). There are office codes that follow the area code format due to the unavailability of office codes.

101 Program—Toll Restriction Disable

Selects whether or not the Toll Restriction feature is to function on a given CO line; the CO key/LEDs represent themselves.

- Mark an X next to each CO key/LED on which Toll Restriction will not function.

102 Program—Forced Account Code Check

This program will require an account code to be dialed for each CO line checked, if a Forced Account Code is required for each station in Program 5#XX. (Has no meaning if EKTs are not selected for Forced Account Code in Program 5#XX.)

- Mark an X next to the CO lines that will be checked for a Forced Account Code for the EKTs selected in Program 5#XX.

103 Program—Equal Access (10XXX) or Other Common Carrier (OCC) #1

Informs the system of the first 5-digit code (Equal Access or OCC) that is ignored for Toll Restriction purposes. Enter the actual Equal Access or OCC digits to be recognized and ignored.

104 Program—OCC Authorization Code #1

Informs the system of the number of digits

in the OCC Authorization Code. These digits will also be ignored for Toll Restriction purposes when an OCC entry is made according to the above instructions. Enter the number of digits in the authorization code.

105 Program—Equal Access (10XXX) or Other Common Carrier (OCC) #2

Informs the system of the second 5-digit code (Equal Access or OCC) that is ignored for Toll Restriction purposes. Enter the actual Equal Access or OCC digits to be recognized and ignored.

106 Program—OCC Authorization Code #2

Informs the system of the number of digits in the OCC Authorization Code. These digits will also be ignored for Toll Restriction purposes when an OCC entry is made according to the above instructions. Enter the number of digits in the authorization code.

1X0 Program—Toll Restriction Class Parameters (X = 1 - 4)

There are four classes of toll restriction available on a station-by-station basis. (See **Program 6XX** to select the station class of toll restriction.) This program defines parameters for each class of toll restriction (X = 1-4). Entry to this program is required only if 3- or 6-digit toll restriction is desired.

- Mark an X next to the LED for each parameter of each toll restriction class used.

INT: Operator or operator-assisted calls are to be restricted (0).

CO1: Overseas operator or unassisted overseas calls are to be restricted (01/011).

CO2: All restricted area codes plus the office code of 555 are allowed (out-of-area directory assistance calls, e.g., 213 + 555 + 1212).

1XY Program—Area Code Table (X = Class 1 - 4) [Y = allow (2), deny (3) or display (4)]

This program defines the area codes allowed or denied for each toll restriction class. Entry to this program is required only if 3- or 6-digit toll restriction is desired. Each class area code table can be defined as an allow (2) or deny (3) table. Initialized data allows all area codes for

each class. All allowed area codes can be displayed (4) for each class. See the detailed programming chart for area code entry procedures.

1XZ Program—Office Code Table (X = Class 1 - 4) [Z = allow (6), deny (7) or display (8)]

This program defines the office codes allowed or denied for each toll restriction class within the home area code (HAC). Entry to this program is required only if 3- or 6-digit toll restriction is desired. Each class office code table can be defined as an allow (6) or deny (7) table. Initialized data allows all office codes in the home area code for each class. All allowed office codes can be displayed (8) for each class. See the detailed programming chart for office code entry procedures.

1X1 Program—Toll Restriction Class Area/Office Code Exception Table Selection (X = Class 1 - 4)

Entry to this program is required only if 6-digit (area/office code) toll restriction is desired. There are eight area/office code exception tables available. These exception tables are shared by all four classes of toll restriction. Each class may use any one or all exception code tables. When an exception code table is selected for a toll restriction class, the dialed area code and office code in that table will be an exception to the normal restriction of that area code. See the examples following **Program 2XY**.

- Mark an X next to the LED of each area/office code exception table (1-8/INT-CO7) to be selected for each toll restriction class.

2XY Program—Area/Office Code Exception Tables

Entry to this program is required only if 6-digit (area/office code) toll restriction is desired. There are eight area/office code exception tables available that are defined by X (1 - 8). Each table may have one area code and up to 800 office codes entered. The area code is entered when Y = 1 for each table, while office codes are added (Y = 2) or deleted (Y = 3) for each table. All office codes currently in the table are displayed when Y = 4. Each area/office code exception table selected with **Program 1X1** will be an exception (opposite) to the

PROGRAMMING PROCEDURES
SECTION 300-006-300
MAY 1986

allow (Program 1X2) or deny (Program 1X3) area code table for each toll restriction class. See the detailed programming chart for area code and office code entry procedures.

The examples below are provided for additional information.

1) Normal restriction (allow all office codes within an area code) for stations in class 1.

- Program 1XY is programmed to allow (112) area code 213. Class 1 stations are allowed to dial all office codes in area code 213.

2) Area/office code exception (allow all office codes within an area code except one) for stations in Class 1.

- Program 1XY remains the same (112).
- Program 1X1 has area/office code exception Table 1 (INT) selected (111).
- Program 2XY (211 and 212) are programmed for area code 213 (211) and office code 635 also (212). Class 1 stations are allowed to dial all office codes in area code 213 except 635.

190 Program—PBX Backup

Informs the system if the CO line key is actually connected to a PBX station line. The system will recognize PBX access codes on selected line(s).

- Mark an X next to each CO key/LED that is to be connected to a PBX station line.

19X Program—PBX Access Codes

Informs the system of the access codes used by the PBX that is connected to the lines selected in Program 190. **Strata V1e** will recognize the access codes and react appropriately for Toll Restriction, Automatic Dialing and Repeat Last Number Dialed.

- Enter actual access codes (maximum: 8).

NOTE:

If the access code is a single digit, enter "" in the second column. If all combinations following a particular first digit are to be considered access codes (e.g., 91, 92, 93, etc.), enter "D" (do not care) in the second column.*

02.60 Station Options:

3XX Program—Station CO Line Access

The ability of an individual station to access any of the CO lines is determined by selections made using this program. A station denied access to a CO line by this program will have neither key nor LED functions for that CO line.

- Selections must be repeated for all stations—mark an X next to each CO key/LED that is to be accessed by the station in question.

4XX Program—Station Type Assignment

Informs the system of the type EKT being used at each station and the order of CO line appearance.

- 1) Mark an X next to CO1 if a 10-key EKT is equipped (see Figure 1A).
- 2) Mark an X next to INT if a 20-key EKT is equipped (see Figure 1B).
- 3) Mark an X next to MW/FL if the CO lines are to be numbered from top to bottom (reverse).
- 4) Mark an X next to AD1 if you want the first CO line number to be CO1. (Location will depend on the selection at MW/FL.)
- 5) Mark an X next to AD2 if you want the first CO line number to be CO4. (Location will depend on the selection at MW/FL.)

4#XX Program—Station Flexible Key Assignment

Informs the system of what features are assigned to the flexible keys at each station.

Any key (except INT) may be assigned a feature code (Figure 2). All assigned feature codes have priority over Program 4XX assignments. For each key on every station, write in the name or code for each feature to be assigned.

NOTE:

Except for AD keys, a feature will be rejected if you try to enter it at another key once its code has been entered.

5XX Program—Station Class of Service #1

Sixteen options are selected with this program, using the various keys to change the

CODES	DESCRIPTIONS
01	CO1
02	CO2
03	CO3
04	CO4
05	CO5
06	CO6
*	ADL starting from bottom key assigned ADL1
82	Pick up (Tenant 2) ringing CO in Night Service (CPU2)
83	Pick up (Tenant 1) ringing CO in Night Service (CPU1)
84	Pick up (Tenants 1 and 2) ringing CO in Night Service (CPU)
85	Save number dialed (SAVE)
86	Door lock (DRLK)
87	Call forward (CFD)
88	Microphone cutoff (MCO)
90	LED ON: DTMF tones on CO/LED OFF: DP (TONE)
91XX	DSS to station XX (DSS1)
92XX	DSS to station XX (DSS2)
93	Privacy (PRV)
94	Automatic callback (ACB)
95	Pause (PAU)
96	Automatic Redial (REP must be assigned also) (RDL)
97	Repertory dial (RDL must be assigned also) (REP)
98	Do not disturb (DND)
99	Message waiting/flash (MW/FL)

FIGURE 2—FEATURE KEY ASSIGNMENTS

status of their respective LEDs. The selections listed below must be repeated for each station. In all cases, mark an X where required.

1) Privacy Override—mark an X next to PAU if the station is **allowed** the Privacy Override feature.

NOTE:

A maximum of two stations are permitted to use the Privacy Override feature. If more than two are programmed, only the two lowest numbered stations will be allowed to use this feature and the others will be ignored.

2) DND Override—mark an X next to AD7 if the station is **allowed** the DND Override feature.

3) Executive Override Allowed (Dial 3)—mark

an X next to AD6 for the station that is **allowed** the Executive Override feature. (No limit to the number of stations.)

4) Door Phone "C" Ring—mark an X next to AD3 if the door phone unit connected to the Door Phone Control Box output "C" is to ring this EKT. Leave blank if this EKT is not to ring.

5) Door Phone "B" Ring—mark an X next to AD2 if the door phone unit connected to the Door Phone Control Box output "B" is to ring this EKT. Leave blank if this EKT is not to ring.

6) Door Phone "A" Ring—mark an X next to AD1 if the door phone unit connected to the Door Phone Control Box output "A" is to ring this EKT. Leave blank if this EKT is not to ring.

7) Group Page 4—mark an X next to MW/FL if the station is **included** in Group Page 4.

PROGRAMMING PROCEDURES
SECTION 300-006-300
MAY 1986

8) Group Page 3—mark an X next to DND if the station is **included** in Group Page 3.

9) Group Page 2—mark an X next to ACB if the station is **included** in Group Page 2.

10) Group Page 1—mark an X next to CO6 if the station is **included** in Group Page 1.

11) All Call Page Allowed—mark an X next to CO5 if the station is **included** in an All Call Page.

12) Room Monitor/Warning Tone—mark an X next to CO4 if no warning tone will be heard when dialing a room monitor from this EKT. Leave blank if a warning tone will be heard at the room monitor.

13) Handsfree Answerback Disable—mark an X next to CO3 if Handsfree Answerback is to be disabled. Leave blank if it is not to be disabled (see MCO key feature).

14) MIC LED ON—mark an X next to CO2 if the microphone is to be ON in the idle mode. Leave blank if the microphone on the EKT is to be OFF in the idle mode.

15) **MIC** Key Lock—mark an X next to CO1 if the **MIC** key is to be operated in the push on/push off mode. Leave blank if momentary operation is required.

16) Speakerphone Enable—mark an X next to INT if the station is **allowed** to use the Speakerphone feature.

5#XX Program—Station Class of Service #2

Eleven additional Class of Service features are selected with this program using the various keys to change the status of their respective LEDs. The selections listed below must be repeated for each station. In all cases mark an X where required.

1) Station-to-Station Message Waiting with LCD Display—mark an X next to AD7 if the station is **allowed** the Station-to-Station Messaging feature.

2) Forced Account Code—mark an X next to AD5 if this station is **required** to use an account code.

3) Hold Recall Time—referring to Table 1, mark an X next to the combination of

AD1, AD2 and AD3 that corresponds to the recall time desired for each station. If all locations are left blank, the timing for that station will be according to **Program 05**.

TABLE 1
HOLD RECALL TIME CODE

Key/LED	16 sec.	32 sec.	48 sec.	64 sec.	96 sec.	128 sec.	160 sec.
AD 2 [CO 1]				X	X	X	X
AD 1 [INT]		X	X			X	X
MW/FL	X		X		X		X

4) Automatic Off-Hook Selection—mark an X next to ACB if automatic off-hook selection will be CO line Group 94.

5) Mark an X next to CO6 if automatic off-hook selection will be CO line Group 93.

6) Mark an X next to CO5 if automatic off-hook selection will be CO line Group 92.

7) Mark an X next to CO4 if automatic off-hook selection will be CO line Group 91.

8) Mark an X next to CO3 if automatic off-hook selection will be the CO line assigned to CO 1 position.

9) Mark an X next to CO2 if automatic off-hook selection will be INT.

NOTE:

In Program 01, if AD6 is left blank, items 4, 5, 6 and 7 above will select Dial 9. The lowest selection of automatic off-hook will have priority.

10) Ringing Line Preference—mark an X next to CO1 if the station is allowed the Ringing Line Preference feature.

11) Automatic Dial Allowed—mark an X next to INT if the station is allowed the Automatic Dialing feature.

6XX Program—Toll Restriction Classification

Defines the **type** of Toll Restriction that will be functional on individual stations. Selections must be made for each station:

1) Mark an X next to CO6 if Toll Restriction Class 4 is **in effect** at this station.

2) Mark an X next to CO5 if Toll Restriction Class 3 is **in effect** at this station.

X next to CO4 if Toll Restriction Class 2 is in effect at this station.

4) Mark an X next to CO3 if Toll Restriction Class 1 is in effect at this station.

5) Mark an X next to CO2 if this station will be restricted from dialing 0 or 1 as the first or second digit. A toll restriction class cannot be used with this entry.

6) Mark an X next to CO1 if the station will be allowed to dial 1 + 7-digit number. A toll restriction class cannot be used with this entry.

7) Mark an X next to INT if this station will not be restricted.

7XX Program—Station Outgoing Call Restriction

Restricts a station from outgoing access to any number of CO lines while leaving it free to answer these lines when they are ringing or on hold. Selections must be made for each station.

- Mark an X next to the CO line that is to have restricted access by the station in question.

8XX Program—CO Ringing Assignments-DAY

Selects which CO lines will ring at a given station when system is in the "DAY" mode. Selections must be made for each station.

- Mark an X next to each CO line that is to ring at the station in question.

8#XX Program—CO Ringing Assignments-DAY 2

Selects which CO lines will ring at a given station when the system is in the "DAY 2" mode. This program is applicable only when the Three Ring Mode option was selected in Program 03. Selections must be made for each station.

- Mark an X next to each CO line that is to ring at the station in question.

9XX Program—CO Ringing Assignments-NITE

Selects which CO lines will ring at a given station when system is in the "NITE" mode.

Selections must be made for each station.

- Mark an X next to each CO line that is to ring at the station in question.

NOTE:

Each line can ring on only eight stations. If more than eight are programmed, only the eight stations with the lowest station numbers will ring.

02.70 Initialization

02.71 Strata VI₆ has a list of standard system data assignments stored in ROM that can be entered any time by initializing the system. The system must be initialized when it is first installed or whenever the VCCU is changed. This allows the system to be tested and any faults corrected before time is spent on programming. Standard data assignments are listed in Table 2.

02.72 To initialize the **Strata VI₆** system:

- a) Make sure the system power switch is in the ON position.
- b) Verify that the battery on the VCCU is connected to ensure that data entered after the system initialization will not be lost due to power failure. (The VCCU SET LED will not function if the battery is not connected.)
- c) Depress and hold in the INT switch on the left side panel.
- d) Depress the SET switch and allow it to lock.
 - The SET LED lights.
 - All LEDs on station 17 (except SPKR and MIC) begin blinking.
- e) Depress and release the SET switch again.
 - SET LED goes off.
 - Station 17 LEDs stop flashing.*

IMPORTANT!

Verify that ALL proper LEDs begin blinking and go off as indicated in steps d) and e) before proceeding.

- f) Release the INT switch.
- g) Cycle the power switch OFF and ON.

02.73 The Automatic Dialing memory will contain random numbers when the system is

PROGRAMMING PROCEDURES
SECTION 300-006-300
MAY 1986

powered up initially. Therefore, it is necessary to clear the memory to prevent meaningless numbers from being dialed.

02.74 The Automatic Dialing-System memory is cleared as follows:

- a) Depress the **SET** switch and allow it to lock.
 - The SET LED lights.
 - The REP LED on station 17 goes on.
- b) Depress the **SPKR** key on station 17.
 - SPKR LED lights steadily.
- c) Dial **# * *** on the dial pad.
 - The SPKR LED flashes continuously.
- d) Depress the **INT CO4 DND** and **AD3** keys.
 - The corresponding LEDs light steadily.
- e) Depress the **HOLD** key.
 - All station 17 LEDs—except REP—go off.
- f) Release the **SET** switch.

- The SET LED goes off.
- The REP LED on station 17 goes off.

02.80 System Data Entry

02.81 System Data is entered via station 17 while the system is in the programming mode.

02.82 The system is placed in the programming mode by locking in the **SET** switch on the left side panel. While the switch is in the locked position, the SET LED and the REP LED on station 17 will remain lit.

02.83 Once the system is in the programming mode, refer to the System Record Sheet for the changes that must be made and select the required program number. Refer to the proper table for detailed instructions for using each different program. Each program should be accomplished sequentially until all necessary changes are made.

TABLE 2
INITIALIZED DATA
SYSTEM OPTIONS

01 Program
System Assignments (Basic)

Alternate point answer of transferred CO line = Allowed
 System Speed Dial Override of Toll Restriction = Not allowed
 CO line groups = 1 (dial 9)
 Two-CO line conference = Allowed
 DP Make Ratio = 40%
 MF Signal Time = 80 ms
 Privacy/Non-Privacy = Privacy
 Station 17 = 20-key EKT
 Incoming Call Abandon = 6 seconds
 Pause Timing After Flash = 1 1/2 seconds
 Pause After Flash = None
 Pause Timing After PBX Access Code = 1 1/2 seconds
 Flash Key Timing = 2 seconds
 Intercom Signalling = Voice first

02 Program
System Assignments (Options)

OPU #1/OPX #21 = Not busy
 Display dialed number timeout = 15 seconds

Night Ringing = excluded from External Page
 Background Music = excluded from External Page
 External Page = not included in All Call Page

0#2 Program
Account Code Digit Length

Number of digits = 6

03 Program
System Assignments (Options)

Station #14 door phone/EKT = EKT
 Station #13 door phone/EKT = EKT
 Station 10 DND/NT (night) key = NT key
 Ringing Modes = 2
 Message Center—station 12 = Not equipped
 Message Center—station 11 = Not equipped
 Message Center—station 10 = Equipped
 Door Lock Time = 3 seconds

04 Program
VCOU Outpulsing Selection

DTMF = Equipped

TABLE 2
INITIALIZED DATA (continued)

05 Program
Automatic Recall From Hold Timing
Recall time = 32 seconds

0#5 Program
Camp-on Timeout
Timeout = 32 seconds

CO LINE OPTIONS

06 Program
Automatic Release On Hold Enable
Disabled = All CO lines

106 Program
OCC Authorization Code #2
Blank

07 Program
Automatic Release On Hold Timing
ESS Timing = All CO lines

1X0 Program
Toll Restriction Class Parameters
01 or 011 = Allowed
0 + = Allowed
AC + 555 = Not allowed

09, 09X Program
CO Line Group Selection
Dial 9 group = All CO lines

1XY Program
Area Code Table

0#9 Program
OPL Line Hunting
Hunting = Not assigned

Blank

1XZ Program
Office Code Table

100 Program
Toll Restriction System Parameters
(Dialing Plan)
Plan selected = AC + NNX 1 + O/C

Blank

1X1 Program
Toll Restriction Class Area/Office Code
Exception Table Selection

101 Program
Toll Restriction Disable
No restriction = All CO lines

Selected = None

2XY Program
Area/Office Code Exception Table

102 Program
Forced Account Code Check
No check = All CO lines*

Blank

190 Program
PBX Backup

103 Program
Equal Access or OCC #1
Blank

CO Operation = All CO lines

19X Program
PBX Access Codes

104 Program
OCC Authorization Code #1
Blank

Codes = None assigned

3XX Program
Station CO Line Access

105 Program
Equal Access or OCC #2
Blank

Access allowed = All lines, all stations

**TABLE 2
INITIALIZED DATA (continued)
STATION OPTIONS**

**4XX Program
Station Type Assignments**

10-key assigned = All stations
CO 1 Start = All stations

**4#XX Program
Station Flexible Key Assignment**

Assignment = Basic key strip

**5XX Program
Station Class of Service #1**

Privacy Override = Not allowed, all stations
DND Override = Not allowed, all stations
Executive Override = Not allowed, all stations
Door phone ring A, B, C = Not selected, all stations
Group Page 84 = Not included
Group Page 83 = Not included
Group Page 82 = Not included
Group Page 81 = Not included
All Call Page = Allowed, all stations
Room Monitor = Warning tone, all stations
Handsfree Answerback = Not allowed, all stations
MIC ON/idle mode = OFF, all stations
MIC key lock = Momentary, all stations
Speakerphone = Allowed, all stations

**5#XX Program
Station Class of Service #2**

Station-to-station message with LCD = Al-

lowed, all stations
Forced Account Code = Not required, all stations
Hold Recall Time = Per **Program 05**
Automatic off-hook selection = No selection, all stations
Ringing line preference = Selected, all stations
Automatic dialing = Allowed, all stations

**6XX Program
Station Toll Restriction Classification**

No Restrictions = All stations

**7XX Program
Station Outgoing Call Restrictions**

No Restrictions = All stations

**8XX Program
CO Ringing Assignments-Day**

Assignment = All lines ring station 10

**8#XX Program
CO Ringing Assignments-Day 2**

Assignment = None

**9XX Program
CO Ringing Assignments-Nite**

Assignment = All lines ring station 11

02.84 The table and page numbers for the various programs follow.

TABLE LIST

Table	Title	Program	Page
3	System Assignments (Basic)	01	16
4	System Assignments (Options)	02	17
5	Account Code Digit Length	0#2	18
6	System Assignments (Options)	03	19
7	VCOU MF/DP Outpulsing Selection	04	20
8	Automatic Recall From Hold Timing	05	21
9	Camp-on Timeout	0#5	22
10	AROH Enable	06	23
11	AROH Timing	07	24
12	Night Ring Over External Page	0#8	25
13	Single CO Line (Dial 9) Group Selection	09	26
14	Four CO Line Group Selection	09X	27
15	OPL Line Hunting	0#9	28
16	Toll Restriction System Parameters	100	29
17	Toll Restriction Disable	101	30
18	Forced Account Code Check	102	31
19	Equal Access or Other Common Carrier (OCC) #1	103	32
20	OCC Authorization Code #1	104	33
21	Equal Access or Other Common Carrier #2	105	34
22	OCC Authorization Code #2	106	35
23	Toll Restriction Class Parameters	1X0	36
24	Toll Restriction Class—Area Code	1XY	37
25	Toll Restriction Class—Office Code	1XZ	38
26	Toll Rest. Class (AOC) Exception Table Selection	1X1	39
27	Area/Office Code Exception	2XY	40
28	PBX Backup	190	41
29	PBX Access Codes	19X	42
30	Station CO Line Access	3XX	43
31	Station Type Assignment	4XX	44
32	Station Flexible Key Assignment	4#XX	45
33	Station Class of Service #1	5XX	46
34	Station Class of Service #2	5#XX	47
35	Toll Restriction Classification	6XX	48
36	Station Outgoing Call Restriction	7XX	49
37	CO Ringing Assignments—DAY	8XX	50
38	CO Ringing Assignments—DAY 2	8#XX	51
39	CO Ringing Assignments—NITE	9XX	52

TABLE 3
PROGRAM 01
SYSTEM ASSIGNMENTS (BASIC)

1) Lock in the SET switch on the HKSU.	SET LED on. Station 17 REP LED on. System is in program mode. Normal functions halt on station 17.	
2) Depress the SPKR key on station 17.	SPKR LED steady on.	
3) Dial 0 1 on the dial pad.	SPKR LED flashes continuously. The various LEDs (see below) will indicate present data.	
4) Refer to the System Record Sheet. Using the various keys, turn the associated LEDs on or off, as required. The detailed meaning of each key/LED is shown below.	An X on the record sheet means the LED should be on. If the LED is already on, depressing the associated key will turn it off and vice versa. LEDs may be turned off and on until the desired pattern is set.	
<i>NOTE:</i> If any key/LED is not shown, it is not used.		
	KEY/LED	LED ON
	PAU	Transfer Privacy
	AD7	System Speed Dial Override Toll Restriction
	AD6*	Four CO Line Groups (91 ~ 94)
	AD5	Two CO Conferencing—Inhibit
	AD3	DP Make Ratio 33%
	AD2	MF Signal Time 160ms
	MW/FL	Non-Privacy
	CO6	Incoming Call Abandon 8 seconds
	CO5	3-second Pause After Flash
	CO4	Insert Pause After Flash
	CO3	3-second Pause (MW/FL or PAU key)
	CO2	0.5-second Flash
	INT	Tone First
		LED OFF
		Alternate point answer of transferred CO line
		Restricted
		One CO Line Group (9)
		Allowed
		40%
		80ms
		Privacy
		6 seconds
		1.5-second Pause
		No Pause
		1.5-second Pause
		2.0-second Flash
		Voice First
5) Depress the HOLD key to place new data in memory.	All station 17 LEDs (except REP) go off.	
6A) Go to Step 2 in another program table ... or ... 6B) Transfer data into working memory per Paragraph 02.06.	SET LED goes off. Station 17 REP LED goes off. New data is stored, previous data is erased.	

*If the AD6 LED is off in this program, see *Program 09*; if AD6 LED is on, see *Program 09X*.

TABLE 4
PROGRAM 02
SYSTEM ASSIGNMENTS (OPTIONS)

1) Lock in the SET switch on the HKSU.	SET LED on. Station 17 REP LED on. System is in program mode. Normal functions halt on station 17.																		
2) Depress the SPKR key on station 17.	SPKR LED steady on.																		
3) Dial 0 2 on dial pad.	SPKR LED flashes continuously. The various LEDs (see below) will indicate present data.																		
4) Refer to the System Record Sheet. Using the various keys, turn the associated LEDs on or off, as required. The detailed meaning of each key/LED is shown below.	An X on the record sheet means the LED should be on. If the LED is already on, depressing the associated key will turn it off and vice versa. LEDs may be turned off and on until the desired pattern is set.																		
<i>NOTE: If any key/LED is not shown, it is not used.</i>																			
	<table border="1" style="width: 100%; border-collapse: collapse;"> <thead> <tr> <th style="width: 15%;">KEY/LED</th> <th style="width: 40%;">LED ON</th> <th style="width: 45%;">LED OFF</th> </tr> </thead> <tbody> <tr> <td>DND</td> <td>OPX#21 Busy</td> <td>Not busy</td> </tr> <tr> <td>CO4</td> <td>Display dialed number (1 minute)</td> <td>15 seconds</td> </tr> <tr> <td>CO2*</td> <td>Night Ring over External Page Allowed</td> <td>Not Allowed</td> </tr> <tr> <td>CO1</td> <td>BGM over External Page Allowed</td> <td>Not Allowed</td> </tr> <tr> <td>INT</td> <td>External Page Included with All Call Page</td> <td>Not Included</td> </tr> </tbody> </table>	KEY/LED	LED ON	LED OFF	DND	OPX#21 Busy	Not busy	CO4	Display dialed number (1 minute)	15 seconds	CO2*	Night Ring over External Page Allowed	Not Allowed	CO1	BGM over External Page Allowed	Not Allowed	INT	External Page Included with All Call Page	Not Included
KEY/LED	LED ON	LED OFF																	
DND	OPX#21 Busy	Not busy																	
CO4	Display dialed number (1 minute)	15 seconds																	
CO2*	Night Ring over External Page Allowed	Not Allowed																	
CO1	BGM over External Page Allowed	Not Allowed																	
INT	External Page Included with All Call Page	Not Included																	
5) Depress the HOLD key to place new data in memory.	All station 17 LEDs (except REP) go off.																		
6A) Go to Step 2 in another program table ... or ... 6B) Transfer data into working memory per Paragraph 02.06 .	SET LED goes off. Station 17 REP LED goes off. New data is stored, previous data is erased.																		

* If the CO2 LED is turned on in this program, **Program 0#8** must also be run.

PROGRAMMING PROCEDURES
SECTION 300-006-300
MAY 1986

TABLE 5
PROGRAM 0#2
ACCOUNT CODE DIGIT LENGTH ASSIGNMENT

1) Lock in the SET switch on the HKSU.	SET LED on. Station 17 REP LED on. System is in program mode. Normal functions halt on station 17.																																																																														
2) Depress the SPKR key on station 17.	SPKR LED steady on.																																																																														
3) Dial 0 # 2 on the dial pad.	SPKR LED flashes continuously. The various LEDs (see below) will indicate present data.																																																																														
4) Refer to the System Record Sheet. Using the various keys, turn the associated LEDs on or off, as required. The detailed meaning of each key/LED is shown below.	If the LED is already on, depressing the associated key will turn it off and vice versa. LEDs may be turned off and on until the desired pattern is set. INT, CO1, CO2, CO3 & CO4 will light to display data in binary form.																																																																														
<p>NOTE:</p> <p>1. Depressing the # key displays the data without changing it.</p> <p>2. To clear existing data without entering a new number, depress the # key two times.</p> <p>3. Initialized Data: 6 digits.</p>																																																																															
<p>X = LED on All LEDs off = no data</p>	<table border="1"> <thead> <tr> <th>Digit Length</th> <th>4</th> <th>5</th> <th>6</th> <th>7</th> <th>8</th> <th>9</th> <th>10</th> <th>11</th> <th>12</th> <th>13</th> <th>14</th> <th>15</th> </tr> </thead> <tbody> <tr> <td>CO4</td> <td></td> <td></td> <td></td> <td></td> <td></td> <td></td> <td>X</td> <td>X</td> <td>X</td> <td>X</td> <td>X</td> <td>X</td> </tr> <tr> <td>CO3</td> <td></td> <td></td> <td></td> <td></td> <td>X</td> <td>X</td> <td></td> <td></td> <td></td> <td></td> <td></td> <td></td> </tr> <tr> <td>CO2</td> <td>X</td> <td>X</td> <td>X</td> <td>X</td> <td></td> <td></td> <td></td> <td></td> <td></td> <td></td> <td>X</td> <td>X</td> </tr> <tr> <td>CO1</td> <td></td> <td></td> <td>X</td> <td>X</td> <td></td> <td></td> <td></td> <td></td> <td>X</td> <td>X</td> <td></td> <td></td> </tr> <tr> <td>INT</td> <td></td> <td>X</td> <td></td> <td>X</td> <td></td> <td>X</td> <td></td> <td>X</td> <td></td> <td>X</td> <td></td> <td>X</td> </tr> </tbody> </table>	Digit Length	4	5	6	7	8	9	10	11	12	13	14	15	CO4							X	X	X	X	X	X	CO3					X	X							CO2	X	X	X	X							X	X	CO1			X	X					X	X			INT		X		X		X		X		X		X
Digit Length	4	5	6	7	8	9	10	11	12	13	14	15																																																																			
CO4							X	X	X	X	X	X																																																																			
CO3					X	X																																																																									
CO2	X	X	X	X							X	X																																																																			
CO1			X	X					X	X																																																																					
INT		X		X		X		X		X		X																																																																			
5) Depress the HOLD key to place new data in memory.	All station 17 LEDs (except REP) go off. New data is stored, previous data is erased.																																																																														
<p>6A) Go to Step 2 in another program table ... or ...</p> <p>6B) Transfer data into working memory per Paragraph 02.06.</p>	SET LED goes off. Station 17 REP LED goes off.																																																																														

TABLE 6
PROGRAM 03
SYSTEM ASSIGNMENTS (OPTIONS)

1) Lock in the SET switch on the HSKU.	SET LED on. Station 17 REP LED on. System is in program mode. Normal functions halt on station 17.																																							
2) Depress the SPKR key on station 17.	SPKR LED steady on.																																							
3) Dial 0 3 on the dial pad.	SPKR LED flashes continuously. CO, DND & MW/FL LEDs will be on according to present data.																																							
4) Refer to the System Record Sheet. Using the various keys, turn the associated LEDs on or off, as required. The detailed meaning of each key/LED is shown below.	An X on the record sheet means the LED should be on. If the LED is already on, depressing the associated key will turn it off and vice versa. LEDs may be turned off and on until the desired pattern is set.																																							
NOTE: <i>If any key/LED is not shown, it is not used.</i>																																								
	<table border="1" style="width: 100%; border-collapse: collapse;"> <thead> <tr> <th style="width: 15%;">KEY/LED</th> <th style="width: 40%;">LED ON</th> <th style="width: 45%;">LED OFF</th> </tr> </thead> <tbody> <tr> <td>PAU</td> <td>Door Lock Time 6 seconds</td> <td>3 seconds</td> </tr> <tr> <td>AD7</td> <td>Alarm C</td> <td>Door Phone C</td> </tr> <tr> <td>AD6</td> <td>Door Lock B</td> <td>Door Phone B</td> </tr> <tr> <td>AD5</td> <td>Door Phone C Busy Out</td> <td>No Busy Tone C</td> </tr> <tr> <td>AD4</td> <td>Door Phone B Busy Out</td> <td>No Busy Tone B</td> </tr> <tr> <td>AD3</td> <td>Station 14 is a Door Phone</td> <td>Station 14 is an EKT</td> </tr> <tr> <td>AD2</td> <td>Station 13 is a Door Phone</td> <td>Station 13 is an EKT</td> </tr> <tr> <td>MW/FL</td> <td>Station 10 has DND key</td> <td>Station 10 has NT key</td> </tr> <tr> <td>DND</td> <td>Night Ringing—3-ring mode</td> <td>2-ring mode</td> </tr> <tr> <td>CO 4</td> <td>Message Center—Station 12</td> <td>Not Equipped</td> </tr> <tr> <td>CO 3</td> <td>Message Center—Station 11</td> <td>Not Equipped</td> </tr> <tr> <td>CO 2</td> <td>Message Center—Station 10</td> <td>Not Equipped</td> </tr> </tbody> </table>	KEY/LED	LED ON	LED OFF	PAU	Door Lock Time 6 seconds	3 seconds	AD7	Alarm C	Door Phone C	AD6	Door Lock B	Door Phone B	AD5	Door Phone C Busy Out	No Busy Tone C	AD4	Door Phone B Busy Out	No Busy Tone B	AD3	Station 14 is a Door Phone	Station 14 is an EKT	AD2	Station 13 is a Door Phone	Station 13 is an EKT	MW/FL	Station 10 has DND key	Station 10 has NT key	DND	Night Ringing—3-ring mode	2-ring mode	CO 4	Message Center—Station 12	Not Equipped	CO 3	Message Center—Station 11	Not Equipped	CO 2	Message Center—Station 10	Not Equipped
KEY/LED	LED ON	LED OFF																																						
PAU	Door Lock Time 6 seconds	3 seconds																																						
AD7	Alarm C	Door Phone C																																						
AD6	Door Lock B	Door Phone B																																						
AD5	Door Phone C Busy Out	No Busy Tone C																																						
AD4	Door Phone B Busy Out	No Busy Tone B																																						
AD3	Station 14 is a Door Phone	Station 14 is an EKT																																						
AD2	Station 13 is a Door Phone	Station 13 is an EKT																																						
MW/FL	Station 10 has DND key	Station 10 has NT key																																						
DND	Night Ringing—3-ring mode	2-ring mode																																						
CO 4	Message Center—Station 12	Not Equipped																																						
CO 3	Message Center—Station 11	Not Equipped																																						
CO 2	Message Center—Station 10	Not Equipped																																						
5) Depress the HOLD key to place new data in memory.	All station 17 LEDs (except REP) go off.																																							
6A) Go to Step 2 in another program table ... or ... 6B) Transfer data into working memory per Paragraph 02.06 .	SET LED goes off. Station 17 REP LED goes off. New data is stored, previous data is erased.																																							

TABLE 7
PROGRAM 04
VCOU MF/DP OUTPUTSING SELECTION

<p>1) Lock in the SET switch on the HKSU.</p>	<p>SET LED on. Station 17 REP LED on. System is in program mode. Normal functions halt on station 17.</p>
<p>2) Depress the SPKR key on station 17.</p>	<p>SPKR LED steady on.</p>
<p>3) Dial 0 4 on the dial pad.</p>	<p>SPKR LED flashes continuously. CO LEDs go on according to present data.</p>
<p>4) Refer to the System Record Sheet. Each CO line represents itself: • LED OFF = DTMF • LED ON = DP</p>	<p>An X on the record sheet means the LED should be on. If the LED is already on, depressing the associated key will turn it off and vice versa. LEDs may be turned off and on until the desired pattern is set.</p>
<p>5) Depress the HOLD key to place new data in memory.</p>	<p>All station 17 LEDs (except REP) go off.</p>
<p>6A) Return to Step 2 in order to continue with this program ... or ... 6B) Go to Step 2 in another program table ... or ... 6C) Transfer data into working memory per Paragraph 02.06.</p>	<p>SET LED goes off. Station 17 REP LED goes off. New data is stored, previous data is erased.</p>

TABLE 8
PROGRAM 05
AUTOMATIC RECALL FROM HOLD TIMING

(This program is used only if MW/FL, AD 1 and AD 2 LEDs are ALL off in Program 5XX.)

1) Lock in the SET switch on the HKSU .	SET LED on. Station 17 REP LED on. System is in program mode. Normal functions halt on station 17.																			
2) Depress the SPKR key on station 17.	SPKR LED steady on.																			
3) Dial 0 5 on the dial pad.	SPKR LED flashes continuously. An INT, CO or ACB LED will be on according to present data.																			
4) Refer to the System Record Sheet. Using the various keys, turn one associated LED on or off, as required. The detailed meaning of each key/LED is shown below.	An X on the record sheet means the LED should be on. Only one LED is permitted to be on, depressing another key will turn that LED on and turn off the previous LED.																			
NOTE: If any key/LED is not shown, it is not used.																				
	<table border="1"> <thead> <tr> <th>KEY/LED</th> <th>LED ON</th> </tr> </thead> <tbody> <tr> <td>ACB</td> <td>160 seconds</td> </tr> <tr> <td>CO 6</td> <td>128 seconds</td> </tr> <tr> <td>CO 5</td> <td>96 seconds</td> </tr> <tr> <td>CO 4</td> <td>64 seconds</td> </tr> <tr> <td>CO 3</td> <td>48 seconds</td> </tr> <tr> <td>CO 2</td> <td>32 seconds</td> </tr> <tr> <td>CO 1</td> <td>16 seconds</td> </tr> <tr> <td>INT</td> <td>No Recall</td> </tr> </tbody> </table>	KEY/LED	LED ON	ACB	160 seconds	CO 6	128 seconds	CO 5	96 seconds	CO 4	64 seconds	CO 3	48 seconds	CO 2	32 seconds	CO 1	16 seconds	INT	No Recall	
KEY/LED	LED ON																			
ACB	160 seconds																			
CO 6	128 seconds																			
CO 5	96 seconds																			
CO 4	64 seconds																			
CO 3	48 seconds																			
CO 2	32 seconds																			
CO 1	16 seconds																			
INT	No Recall																			
5) Depress the HOLD key to place new data in memory.	All station 17 LEDs (except REP) go off.																			
6A) Go to Step 2 in another program table ... or ... 6B) Transfer data into working memory per Paragraph 02.06 .	SET LED goes off. Station 17 REP LED goes off. New data is stored, previous data is erased.																			

PROGRAMMING PROCEDURES
SECTION 300-006-300
MAY 1986

TABLE 9
PROGRAM 0#5
CAMP-ON TIMEOUT

1) Lock in the SET switch on the HKSU .	SET LED on. Station 17 REP LED on. System is in program mode. Normal functions halt on station 17.		
2) Depress the SPKR key on station 17.	SPKR LED steady on.		
3) Dial 0 # 5 on the dial pad.	SPKR LED flashes continuously. The INT or a CO LED will go on according to present data.		
4) Refer to the System Record Sheet. Using the various keys, turn one associated LED on or off, as required. The detailed meaning of each key/LED is shown below.	An X on the record sheet means the LED should be on. Only one LED is permitted to be on, depressing another key will turn that LED on and turn off the previous LED.		
<i>NOTE: If any key/LED is not shown, it is not used.</i>			
	KEY/LED	LED ON	
	CO 3	64 seconds	
	CO 2	48 seconds	
	CO 1	32 seconds	
	INT	16 seconds	
5) Depress the HOLD key to place new data in memory.	All station 17 LEDs(except REP)go off.		
6A) Go to Step 2 in another program table ... or ... 6B) Transfer data into working memory per Paragraph 02.06 .	SET LED goes off. Station 17 REP LED goes off. New data is stored, previous data is erased.		

TABLE 10
PROGRAM 06
AUTOMATIC RELEASE ON HOLD ENABLE

<p>1) Lock in the SET switch on the HKSU .</p>	<p>SET LED on. Station 17 REP LED on. System is in program mode. Normal functions halt on station 17.</p>
<p>2) Depress the SPKR key on station 17.</p>	<p>SPKR LED steady on.</p>
<p>3) Dial 0 6 on the dial pad.</p>	<p>SPKR LED flashes continuously. CO LEDs go on according to present data.</p>
<p>4) Refer to the System Record Sheet. Using the CO keys, turn the associated LEDs on or off, as required. Each CO key/LED represents itself—that is, if CO 1 LED is on, CO 1 will have AROH during normal operation. If CO 1 LED is off, AROH will not function on that line.</p>	<p>An X on the record sheet means the LED should be on. If the LED is already on, depressing the associated key will turn it off and vice versa. LEDs may be turned off and on until the desired pattern is set.</p>
<p>5) Depress the HOLD key to place new data in memory.</p>	<p>All station 17 LEDs (except REP) go off.</p>
<p>6A) Return to Step 2 in order to continue with this program ... or ... 6B) Go to Step 2 in another program table ... or ... 6C) Transfer data into working memory per Paragraph 02.06.</p>	<p>SET LED goes off. Station 17 REP LED goes off. New data is stored, previous data is erased.</p>

TABLE 11
PROGRAM 07
AUTOMATIC RELEASE ON HOLD (AROH) TIMING

<p>1) Lock in the SET switch on the HKSU.</p>	<p>SET LED on. Station 17 REP LED on. System is in program mode. Normal functions halt on station 17.</p>
<p>2) Depress the SPKR key on station 17.</p>	<p>SPKR LED steady on.</p>
<p>3) Dial 0 7 on the dial pad.</p>	<p>SPKR LED flashes continuously. CO LEDs go on according to present data.</p>
<p>4) Refer to the System Record Sheet. Using the CO keys, turn the associated LEDs on or off, as required. Each CO key/LED represents itself—that is, if CO 1 LED is on, CO 1 will have XB (crossbar) timing for AROH. If CO 1 LED is off, ESS timing will be used on that line.</p>	<p>An X on the record sheet means the LED should be on. If the LED is already on, depressing the associated key will turn it off and vice versa. LEDs may be turned off and on until the desired pattern is set.</p>
<p>5) Depress the HOLD key to place new data in memory.</p>	<p>All station 17 LEDs (except REP) go off.</p>
<p>6A) Return to Step 2 in order to continue with this program ... or ... 6B) Go to Step 2 in another program table ... or ... 6C) Transfer data into working memory per Paragraph 02.06.</p>	<p>SET LED goes off. Station 17 REP LED goes off. New data is stored, previous data is erased.</p>

NOTE:
This program will have no meaning unless AROH is enabled via Program 06.

TABLE 12
PROGRAM 0#8
NIGHT RING OVER EXTERNAL PAGE

1) Lock in the SET switch on the HKSU.	SET LED on. Station 17 REP LED on. System is in program mode. Normal functions halt on station 17.
2) Depress the SPKR key on station 17.	SPKR LED steady on.
3) Dial 0 # 8 on the dial pad.	SPKR LED flashes continuously. CO LEDs go on according to present data.
4) Refer to the System Record Sheet. This program assigns either Ring or No Ring for each CO line in night operation. Using the CO keys, turn the associated LEDs on or off, as required. Each CO key/LED represents itself—that is, if CO1 LED is on, when the system is in night operation, incoming calls over that CO line will ring over the external page; if CO1 LED is off, incoming calls over that CO line will not ring in night operation.	An X on the record sheet means the LED should be on. If the LED is already on, depressing the associated key will turn it off and vice versa. LEDs may be turned off and on until the desired pattern is set. Initialized Data: All LEDs on.
5) Depress the HOLD key to place new data in memory.	All station 17 LEDs (except REP) go off.
6A) Return to Step 2 in order to continue with this program ... or ... 6B) Go to Step 2 in another program table ... or ... 6C) Transfer data into working memory per Paragraph 02.06 .	SET LED goes off. Station 17 REP LED goes off. New data is stored, previous data is erased.

NOTE:
Use this program only if CO2 LED is on in Program 02.

PROGRAMMING PROCEDURES
SECTION 300-006-300
MAY 1986

TABLE 13
PROGRAM 09
SINGLE CO LINE (DIAL 9) GROUP SELECTION

<p>1) Lock in the SET switch on the HKSU.</p>	<p>SET LED on. Station 17 REP LED on. System is in program mode. Normal functions halt on station 17.</p>
<p>2) Depress the SPKR key on station 17.</p>	<p>SPKR LED steady on.</p>
<p>3) Dial 0 9 on the dial pad.</p>	<p>SPKR LED flashes continuously. CO LEDs go on according to present data.</p>
<p>4) Refer to the System Record Sheet. Using the CO keys, turn the associated LEDs on or off, as required. Each CO key/LED represents itself—that is, if CO1 LED is on, CO 1 will be included in the "Dial 9" group for random selection by a single line (OPX) extension or by any station using Trunk Queuing. If CO1 LED is off, CO1 can be accessed only by dialing 7 0 1 at the OPX station or by the CO1 key on an EKT.</p>	<p>An X on the record sheet means the LED should be on. If the LED is already on, depressing the associated key will turn it off and vice versa. LEDs may be turned off and on until the desired pattern is set.</p>
<p>5) Depress the HOLD key to place new data in memory.</p>	<p>All station 17 LEDs (except REP) go off.</p>
<p>6A) Return to Step 2 in order to continue with this program . . . or . . . 6B) Go to Step 2 in another program table . . . or . . . 6C) Transfer data into working memory per Paragraph 02.06.</p>	<p>SET LED goes off. Station 17 REP LED goes off. New data is stored, previous data is erased.</p>

NOTE:
 Use this program only if the AD6 LED is turned off in **Program 01**.

TABLE 14
PROGRAM 09X
FOUR CO LINE (DIAL 91, 92, 93, 94) GROUP SELECTION

1) Lock in the SET switch on the HKSU.	SET LED on. Station 17 REP LED on. System is in program mode. Normal functions halt on station 17.
2) Depress the SPKR key on station 17.	SPKR LED steady on.
3) Dial 0 9 X on the dial pad. (X = 1, 2, 3 or 4 depending upon the group being defined). Dial 0 9 1 for "dial 91" group; 0 9 2 for "dial 92" group, etc.	SPKR LED flashes continuously. CO LEDs go on according to present data.
4) Refer to the System Record Sheet. Using the CO keys, turn the associated LEDs on or off, as required. Each CO key/LED represents itself—that is, if CO1 LED is on, CO 1 will be included in the "Dial 9X" group for random selection by a single line (OPX) extension or by any station using Trunk Queuing. If CO1 LED is off, CO 1 can be accessed only by dialing 7 0 1 at the OPX station or by the CO1 key on an EKT.	An X on the record sheet means the LED should be on. If the LED is already on, depressing the associated key will turn it off and vice versa. LEDs may be turned off and on until the desired pattern is set.
5) Depress the HOLD key to place new data in memory.	All station 17 LEDs (except REP) go off.
6A) Return to Step 2 in order to continue with this program ... or ... 6B) Go to Step 2 in another program table ... or ... 6C) Transfer data into working memory per Paragraph 02.06.	SET LED goes off. Station 17 REP LED goes off. New data is stored, previous data is erased.

NOTE:
Use this program only if the AD6 LED is turned on in Program 01.

**TABLE 15
PROGRAM 0#9
OPL LINE HUNTING**

<p>1) Lock in the SET switch on the HKSU.</p>	<p>SET LED on. Station 17 REP LED on. System is in program mode. Normal functions halt on station 17.</p>
<p>2) Depress the SPKR key on station 17.</p>	<p>SPKR LED steady on.</p>
<p>3) Dial 0 # 9 on the dial pad.</p>	<p>SPKR LED flashes continuously. CO LEDs go on according to present data.</p>
<p>4) Refer to the System Record Sheet. Using the CO keys, turn the associated LEDs on or off, as required. Each CO key/LED represents itself—that is, if COs 1 & 2 LEDs are on, an incoming call at CO2 will ring the CO 1 OPL station if CO1 is idle. Lines must function in groups of three as they appear on the HOLB, <i>and</i> the lowest numbered line <i>must</i> be selected.</p>	<p>An X on the record sheet means the LED should be on. If the LED is already on, depressing the associated key will turn it off and vice versa. LEDs may be turned off and on until the desired pattern is set.</p>
<p>5) Depress the HOLD key to place new data in memory.</p>	<p>All station 17 LEDs (except REP) go off.</p>
<p>6A) Return to Step 2 in order to continue with this program ... or ... 6B) Go to Step 2 in another program table ... or ... 6C) Transfer data into working memory per Paragraph 02.06.</p>	<p>SET LED goes off. Station 17 REP LED goes off. New data is stored, previous data is erased.</p>

TABLE 16
PROGRAM 100
TOLL RESTRICTION SYSTEM PARAMETERS
(DIALING PLAN)

1) Lock in the SET switch on the HKSU.	SET LED on. Station 17 REP LED on. System is in program mode. Normal functions halt on station 17.
2) Depress the SPKR key on station 17.	SPKR LED steady on.
3) Dial 1 0 0 on the dial pad.	SPKR LED flashes continuously. CO LEDs go on according to present data.
4) Refer to the System Record Sheet. Turn the associated LED on for the display plan to be used. Only one LED may be on at one time.	An X on the record sheet means the LED should be on. If the LED is already on, depressing the associated key will turn it off and vice versa. LEDs may be turned off and on until the desired pattern is set.
5) Depress the HOLD key to place new data in memory.	All station 17 LEDs (except REP) go off. New data is stored, previous data is erased.
6A) Go to Step 2 in another program table ... or ... 6B) Transfer data into working memory per Paragraph 02.06 .	SET LED goes off. Station 17 REP LED goes off. New data is stored, previous data is erased.

TABLE 17
PROGRAM 101
TOLL RESTRICTION DISABLE

<p>1) Lock in the SET switch on the HKSU.</p>	<p>SET LED on. Station 17 REP LED on. System is in program mode. Normal functions halt on station 17.</p>
<p>2) Depress the SPKR key on station 17.</p>	<p>SPKR LED steady on.</p>
<p>3) Dial 1 0 1 on the dial pad.</p>	<p>SPKR LED flashes continuously. CO LEDs go on according to present data.</p>
<p>4) Refer to the System Record Sheet. This program either enables or disables the toll restriction for each CO line in the system. Each CO key/LED represents itself—that is, if CO 1 LED is on, toll restriction is not applied to that CO line; if CO1 LED is off, toll restriction is applied to that CO line.</p>	<p>An X on the record sheet means the LED should be on. If the LED is already on, depressing the associated key will turn it off and vice versa. LEDs may be turned off and on until the desired pattern is set. Initialized Data: All LEDs off.</p>
<p>5) Depress the HOLD key to place new data in memory.</p>	<p>All station 17 LEDs (except REP) go off.</p>
<p>6A) Return to Step 2 in order to continue with this program ... or ... 6B) Go to Step 2 in another program table ... or ... 6C) Transfer data into working memory per Paragraph 02.06.</p>	<p>SET LED goes off. Station 17 REP LED goes off. New data is stored, previous data is erased.</p>

TABLE 18
PROGRAM 102
FORCED ACCOUNT CODE CHECK

1) Lock in the SET switch on the HKSU.	SET LED on. Station 17 REP LED on. System is in program mode. Normal functions halt on station 17.
2) Depress the SPKR key on station 17.	SPKR LED steady on.
3) Dial 1 0 2 on the dial pad.	SPKR LED flashes continuously. CO LEDs go on according to present data.
4) Refer to the System Record Sheet. This program determines whether Forced Account Codes will be checked on a CO-line-by-CO-line basis. Using the CO keys, turn their associated LEDs on or off, as required. <ul style="list-style-type: none"> • LED on = Forced Account Codes are checked. • Each CO key/LED represents itself—that is, if the CO 1 LED is on, stations calling out over CO1 will be forced to enter an account code. 	An X on the record sheet means the LED should be on. If the LED is already on, depressing the associated key will turn it off and vice versa. LEDs may be turned off and on until the desired pattern is set. Initialized Data: All LEDs off.
5) Depress the HOLD key to place new data in memory.	All station 17 LEDs (except REP) go off.
6A) Return to Step 2 in order to continue with this program <p style="text-align: center;">... or ...</p> 6B) Go to Step 2 in another program table <p style="text-align: center;">... or ...</p> 6C) Transfer data into working memory per Paragraph 02.06 .	SET LED goes off. Station 17 REP LED goes off. New data is stored, previous data is erased.

NOTE:

Program 0#2 defines account code digit length.

PROGRAMMING PROCEDURES
SECTION 300-006-300
MAY 1986

TABLE 19
PROGRAM 103
EQUAL ACCESS #1

1) Lock in the SET switch on the HKSU.		SET LED on. Station 17 REP LED on. System is in program mode. Normal functions halt on station 17.									
2) Depress the SPKR key on station 17.		SPKR LED steady on.									
3) Dial 1 0 3 on the dial pad.		SPKR LED flashes continuously. CO LEDs indicate present data.									
4) Refer to the System Record Sheet. This program registers the first equal access (OCC) number used by the system. This five-digit number is entered via the dial pad.		As each digit is entered, the entry is verified by LEDs as shown below. Initialized Data: Blank (AD4 flashing).									
	KEY	START	1st Digit	2nd Digit	3rd Digit	4th Digit	5th Digit				
	AD5					Steady	Steady				
	AD3			Steady	Steady						
	AD4	Flash	Steady		Steady		Steady				
Binary Numbers:		1	2	3	4	5	6	7	8	9	0
CO3									X	X	X
CO2					X	X	X	X			
CO1			X	X			X	X			X
INT		X		X		X		X		X	
X = LED on All LEDs off = no data											
5) Depress the HOLD key to place new data in memory.		All station 17 LEDs (except REP) go off. New data is stored, previous data is erased.									
6A) Return to Step 2 in order to continue with this program ... or ...		SET LED goes off. Station 17 REP LED goes off.									
6B) Go to Step 2 in another program table ... or ...											
6C) Transfer data into working memory per Paragraph 02.06 .											

TABLE 20
PROGRAM 104
OCC AUTHORIZATION CODE LENGTH #1

1) Lock in the SET switch on the HKSU.	SET LED on. Station 17 REP LED on. System is in program mode. Normal functions halt on station 17.																																																																		
2) Depress the SPKR key on station 17.	SPKR LED steady on.																																																																		
3) Dial 1 0 4 on the dial pad.	SPKR LED flashes continuously. CO LEDs indicate present data.																																																																		
4) Refer to the System Record Sheet. This program defines the length of the authorization code for OCC #1. This two-digit number is entered via the dial pad.	As each digit is entered, the entry is verified by LEDs as shown below. Initialized Data: Blank (AD1 flashing).																																																																		
	<table border="1" style="width: 100%; border-collapse: collapse; text-align: center;"> <tr> <td style="width: 15%;">KEY</td> <td style="width: 15%;">START</td> <td style="width: 25%;">1st Digit</td> <td style="width: 45%;">2nd Digit</td> </tr> <tr> <td>AD3</td> <td></td> <td></td> <td>Steady</td> </tr> <tr> <td>AD1</td> <td>Flash</td> <td>Steady</td> <td></td> </tr> </table>	KEY	START	1st Digit	2nd Digit	AD3			Steady	AD1	Flash	Steady																																																							
KEY	START	1st Digit	2nd Digit																																																																
AD3			Steady																																																																
AD1	Flash	Steady																																																																	
<table border="1" style="width: 100%; border-collapse: collapse;"> <tr> <td style="width: 35%; text-align: right;">Binary Numbers:</td> <td style="width: 5%;">1</td> <td style="width: 5%;">2</td> <td style="width: 5%;">3</td> <td style="width: 5%;">4</td> <td style="width: 5%;">5</td> <td style="width: 5%;">6</td> <td style="width: 5%;">7</td> <td style="width: 5%;">8</td> <td style="width: 5%;">9</td> <td style="width: 5%;">0</td> </tr> <tr> <td style="text-align: right;">X = LED on</td> <td></td><td></td><td></td><td></td><td></td><td></td><td></td><td>X</td><td>X</td><td>X</td> </tr> <tr> <td style="text-align: right;">CO3</td> <td></td><td></td><td></td><td></td><td></td><td></td><td></td><td></td><td></td><td></td> </tr> <tr> <td style="text-align: right;">CO2</td> <td></td><td></td><td></td><td>X</td><td>X</td><td>X</td><td>X</td><td></td><td></td><td></td> </tr> <tr> <td style="text-align: right;">CO1</td> <td></td><td>X</td><td>X</td><td></td><td></td><td>X</td><td>X</td><td></td><td></td><td>X</td> </tr> <tr> <td style="text-align: right;">INT</td> <td>X</td><td></td><td>X</td><td></td><td>X</td><td></td><td>X</td><td></td><td>X</td><td></td> </tr> </table>	Binary Numbers:	1	2	3	4	5	6	7	8	9	0	X = LED on								X	X	X	CO3											CO2				X	X	X	X				CO1		X	X			X	X			X	INT	X		X		X		X		X		
Binary Numbers:	1	2	3	4	5	6	7	8	9	0																																																									
X = LED on								X	X	X																																																									
CO3																																																																			
CO2				X	X	X	X																																																												
CO1		X	X			X	X			X																																																									
INT	X		X		X		X		X																																																										
5) Depress the HOLD key to place new data in memory.	All station 17 LEDs (except REP) go off. New data is stored, previous data is erased.																																																																		
6A) Return to Step 2 in order to continue with this program ... or ... 6B) Go to Step 2 in another program table ... or ... 6C) Transfer data into working memory per Paragraph 02.06.	SET LED goes off. Station 17 REP LED goes off.																																																																		

PROGRAMMING PROCEDURES
SECTION 300-006-300
MAY 1986

TABLE 21
PROGRAM 105
EQUAL ACCESS #2

1) Lock in the SET switch on the HKSU.		SET LED on. Station 17 REP LED on. System is in program mode. Normal functions halt on station 17.									
2) Depress the SPKR key on station 17.		SPKR LED steady on.									
3) Dial 1 0 5 on the dial pad.		SPKR LED flashes continuously. CO LEDs indicate present data.									
4) Refer to the System Record Sheet. This program registers the second equal access (OCC) number used by the system. This five-digit number is entered via the dial pad.		As each digit is entered, the entry is verified by LEDs as shown below. Initialized Data: Blank (AD4 flashing).									
	KEY	START	1st Digit	2nd Digit	3rd Digit	4th Digit	5th Digit				
	AD5					Steady	Steady				
	AD3			Steady	Steady						
	AD4	Flash	Steady		Steady						Steady
Binary Numbers:		1	2	3	4	5	6	7	8	9	0
CO3									X	X	X
CO2					X	X	X	X			
CO1			X	X			X	X			X
INT		X		X		X		X		X	
X = LED on All LEDs off = no data											
5) Depress the HOLD key to place new data in memory.		All station 17 LEDs (except REP) go off. New data is stored, previous data is erased.									
6A) Return to Step 2 in order to continue with this program ... or ... 6B) Go to Step 2 in another program table ... or ... 6C) Transfer data into working memory per Paragraph 02.06 .		SET LED goes off. Station 17 REP LED goes off.									

TABLE 22
PROGRAM 106
OCC AUTHORIZATION CODE LENGTH #2

1) Lock in the SET switch on the HKSU.	SET LED on. Station 17 REP LED on. System is in program mode. Normal functions halt on station 17.																																																							
2) Depress the SPKR key on station 17.	SPKR LED steady on.																																																							
3) Dial 1 0 6 on the dial pad.	SPKR LED flashes continuously. CO LEDs indicate present data.																																																							
4) Refer to the System Record Sheet. This program defines the length of the authorization code for OCC #2. This two-digit number is entered via the dial pad.	As each digit is entered, the entry is verified by LEDs as shown below. Initialized Data: Blank (AD1 flashing).																																																							
	<table border="1" style="width: 100%; border-collapse: collapse; text-align: center;"> <tr> <td style="width: 15%;">KEY</td> <td style="width: 15%;">START</td> <td style="width: 20%;">1st Digit</td> <td style="width: 20%;">2nd Digit</td> </tr> <tr> <td>AD3</td> <td></td> <td></td> <td>Steady</td> </tr> <tr> <td>AD4</td> <td>Flash</td> <td>Steady</td> <td></td> </tr> </table>	KEY	START	1st Digit	2nd Digit	AD3			Steady	AD4	Flash	Steady																																												
KEY	START	1st Digit	2nd Digit																																																					
AD3			Steady																																																					
AD4	Flash	Steady																																																						
<table style="width: 100%; border-collapse: collapse;"> <tr> <td style="width: 35%; text-align: right;">Binary Numbers:</td> <td style="width: 5%;">1</td> <td style="width: 5%;">2</td> <td style="width: 5%;">3</td> <td style="width: 5%;">4</td> <td style="width: 5%;">5</td> <td style="width: 5%;">6</td> <td style="width: 5%;">7</td> <td style="width: 5%;">8</td> <td style="width: 5%;">9</td> <td style="width: 5%;">0</td> </tr> <tr> <td style="text-align: right;">CO3</td> <td></td> <td></td> <td></td> <td></td> <td></td> <td></td> <td></td> <td>X</td> <td>X</td> <td>X</td> </tr> <tr> <td style="text-align: right;">CO2</td> <td></td> <td></td> <td></td> <td>X</td> <td>X</td> <td>X</td> <td>X</td> <td></td> <td></td> <td></td> </tr> <tr> <td style="text-align: right;">CO1</td> <td></td> <td>X</td> <td>X</td> <td></td> <td></td> <td>X</td> <td>X</td> <td></td> <td></td> <td>X</td> </tr> <tr> <td style="text-align: right;">INT</td> <td>X</td> <td></td> <td>X</td> <td></td> <td>X</td> <td></td> <td>X</td> <td></td> <td>X</td> <td></td> </tr> </table> <p style="margin-left: 20px;">X = LED on All LEDs off = no data</p>	Binary Numbers:	1	2	3	4	5	6	7	8	9	0	CO3								X	X	X	CO2				X	X	X	X				CO1		X	X			X	X			X	INT	X		X		X		X		X		
Binary Numbers:	1	2	3	4	5	6	7	8	9	0																																														
CO3								X	X	X																																														
CO2				X	X	X	X																																																	
CO1		X	X			X	X			X																																														
INT	X		X		X		X		X																																															
5) Depress the HOLD key to place new data in memory.	All station 17 LEDs (except REP) go off. New data is stored, previous data is erased.																																																							
6A) Return to Step 2 in order to continue with this program ... or ... 6B) Go to Step 2 in another program table ... or ... 6C) Transfer data into working memory per Paragraph 02.06 .	SET LED goes off. Station 17 REP LED goes off.																																																							

TABLE 23
PROGRAM 1X0
TOLL RESTRICTION CLASS PARAMETERS

1) Lock in the SET switch on the HKSU.	SET LED on. Station 17 REP LED on. System is in program mode. Normal functions halt on station 17.
2) Depress the SPKR key on station 17.	SPKR LED steady on.
3) Dial 1 X 0 on the dial pad. (X = Restriction class 1 ~ 4)	SPKR LED flashes continuously. The various LEDs (see below) will indicate present data.
4) Refer to the System Record Sheet.	An X on the record sheet means the LED should be on.
5) Depress the HOLD key to place new data in memory.	All station 17 LEDs (except REP) go off.
6A) Go to Step 2 in another program table ... or ... 6B) Transfer data into working memory per Paragraph 02.06 .	SET LED goes off. Station 17 REP LED goes off. New data is stored, previous data is erased.

TABLE 24
PROGRAM 1XY
TOLL RESTRICTION CLASS AREA CODE ENTRY
(LCD TELEPHONE)

1) Lock in the SET switch on the HKSU.	SET LED on. Station 17 REP LED on. System is in program mode. Normal functions halt on station 17. LCD is blank.
2) Depress the SPKR key.	SPKR LED steady on. LCD is blank.
3) Dial 1 X 2 (Allow), 1 X 3 (Deny) or 1 X 4 (Display) as required. (X =Restriction class 1 ~ 4).	SPKR LED flashes continuously. LCD displays dialed number.
4) Press # key.	1 X 2 = LCD is blank. 1 X 3 = LCD is blank. 1 X 4 = LCD displays all allowed codes.
5) Enter first area code in range sequence (start)	LCD displays code entered.
6) Depress * key.*	LCD shifts left to provide space for net code.
7) Enter final area code in range sequence (stop).*	LCD displays code entered.
8) Depress # key.	LCD is blank.
9) Return to step 5 to enter additional area codes.	
10) Depress the HOLD key to place new data in memory.	All station 17 LEDs (except REP) go off.
11A) Go to Step 2 in another program table ... or ... 11B) Transfer data into working memory per Paragraph 02.06	SET LED goes off. Station 17 REP LED goes off. New data is stored, previous data is erased.

*Skip steps 6 and 7 if only one area code in sequence is being entered.

TABLE 25
PROGRAM 1XZ
TOLL RESTRICTION CLASS OFFICE CODE ENTRY
(LCD TELEPHONE REQUIRED)

1) Lock in the SET switch on the HKSU.	SET LED on. Station 17 REP LED on. System is in program mode. Normal functions halt on station 17. LCD is blank.
2) Depress the SPKR key.	SPKR LED steady on. LCD is blank.
3) Dial 1 X 6 (Allow), 1 X 7 (Deny) or 1 X 8 (Display) as required. (X = Restriction class 1 ~ 4).	SPKR LED flashes continuously. LCD displays dialed number.
4) Press # key.	1 X 6 = LCD is blank. 1 X 7 = LCD is blank. 1 X 8 = LCD displays all allowed codes.
5) Enter first area code in range sequence (start).	LCD displays code entered.
6) Depress * key.*	LCD shifts left to provide space for net code.
7) Enter final area code in range sequence (stop).*	LCD displays code entered.
8) Depress # key.	LCD is blank.
9) Return to step 5 to enter additional area codes.	
10) Depress the HOLD key to place new data in memory.	All station 17 LEDs (except REP) go off.
11A) Go to Step 2 in another program table ... or ... 11B) Transfer data into working memory per Paragraph 02.06 .	SET LED goes off. Station 17 REP LED goes off. New data is stored, previous data is erased.

*Skip steps 6 and 7 if only one area code in sequence is being entered.

TABLE 26
PROGRAM 1X1
AREA/OFFICE CODE EXCEPTION TABLE SELECTION

1) Lock in the SET switch on the HKSU.	SET LED on. Station 17 REP LED on. System is in program mode. Normal functions halt on station 17.
2) Depress the SPKR key on station 17.	SPKR LED steady on.
3) Dial 1 X 1 on the dial pad. (X = Restriction class 1 ~ 4)	SPKR LED flashes continuously. The various LEDs (see below) will indicate present data.
4) Refer to the System Record Sheet.	An X on the record sheet means the LED should be on.
5) Depress the HOLD key to place new data in memory.	All station 17 LEDs (except REP) go off.
6A) Go to Step 2 in another program table ... or ... 6B) Transfer data into working memory per Paragraph 02.06.	SET LED goes off. Station 17 REP LED goes off. New data is stored, previous data is erased.

PROGRAMMING PROCEDURES
SECTION 300-006-300
MAY 1986

TABLE 27
PROGRAM 2XY
AREA/OFFICE CODE EXCEPTION TABLE
(LCD TELEPHONE REQUIRED)

1) Lock in the SET switch on the HKSU.	SET LED on. Station 17 REP LED on. System is in program mode. Normal functions halt on station 17. LCD is blank.
2) Depress the SPKR key.	SPKR LED steady on. LCD is blank.
3) Dial 2 X 1 X = Table 1 ~ 8	LCD displays dialed number, then shifts left to provide space for next entry (or displays current area code).
4) Enter area code.	LCD clears and displays area code entered. Binary data is shown on INT, CO1, CO2, CO3 keys/LEDs.
5) Depress the HOLD key.	LCD is blank.
6) Depress the SPKR key.	SPKR LED steady on. LCD is blank.
7) Dial 2 X 2 (Allow), 2 X 3 (Delete) or 2 X 4 (Display). X = Table 1 ~ 8.	SPKR LED flashes continuously. LCD displays dialed number.
8) Depress # key.	2 X 2 = LCD is blank. 2 X 3 = LCD is blank. 2 X 4 = LCD displays all currently programmed office codes.
9) Enter first office code in range sequence (start).	LCD displays code enter.
10) Depress * key.*	LCD shifts left to provide space for net code.
11) Enter final area code in range sequence (stop).*	LCD displays code entered.
12) Depress # key.	LCD is blank.
13) Return to step 9 to enter additional office codes.	
14) Depress the HOLD key to place new data in memory.	All station 17 LEDs (except REP) go off.
15A) Go to Step 2 in another program table ... or ... 15B) Transfer data into working memory per Paragraph 02.06	SET LED goes off. Station 17 REP LED goes off. New data is stored, previous data is erased.

*Skip steps 10 and 11 if only one area code in sequence is being entered.

TABLE 28
PROGRAM 190
PBX BACK-UP

1) Lock in the SET switch on the HKSU.	SET LED on. Station 17 REP LED on. System is in program mode. Normal functions halt on station 17.
2) Depress the SPKR key on station 17.	SPKR LED steady on.
3) Dial 1 9 0 on the dial pad.	SPKR LED flashes continuously. CO LEDs go on according to present data.
4) Refer to the System Record Sheet. Using the CO keys, turn the associated LEDs on or off, as required. Each CO key/LED represents itself—that is, if CO 1 LED is on, the system assumes that the CO 1 line is connected to a PBX line and will cause features such as Toll Restriction and Automatic Dialing to function accordingly.	An X on the record sheet means the LED should be on. If the LED is already on, depressing the associated key will turn it off and vice versa. LEDs may be turned off and on until the desired pattern is set.
5) Depress the HOLD key to place new data in memory.	All station 17 LEDs (except REP) go off.
6A) Return to Step 2 in order to continue with this program ... or ... 6B) Go to Step 2 in another program table ... or ... 6C) Transfer data into working memory per Paragraph 02.06 .	SET LED goes off. Station 17 REP LED goes off. New data is stored, previous data is erased.

TABLE 29
PROGRAM 19X
PBX ACCESS CODES

<p>1) Lock in the SET switch on the HKSU.</p>	<p>SET LED on. Station 17 REP LED on. System is in program mode. Normal functions halt on station 17.</p>																																																																										
<p>2) Depress the SPKR key on station 17.</p>	<p>SPKR LED steady on.</p>																																																																										
<p>3) Dial 1 9 X on the dial pad. X = 1, 2, 3, etc.—the system will store a maximum of eight codes. Dial 1 9 1 (X = 1) to program first access code, 1 9 2 (X = 2) to program second access code, etc.</p>	<p>SPKR LED flashes continuously. AD 1 LED will flash.</p>																																																																										
<p>4) Refer to the System Record Sheet. Using the dial pad, enter the required access code (two digits must be entered.)</p> <ul style="list-style-type: none"> • If the access code is a single digit, enter # as the second digit. • If all combinations following a particular first digit are to be considered access codes (e.g., 91, 92, 93, etc.), depress the RDL (DND) key for the second digit. 	<p>INT, CO 2, 4 & 6 LEDs will light to display data in binary format. AD 1 or AD 3 LED will light steadily to indicate which digit is being displayed.</p>																																																																										
	<p>KEY/LED</p>			<p>Start</p>			<p>1st Digit</p>			<p>2nd Digit</p>																																																																	
	<p>AD 3</p>									<p>Steady</p>																																																																	
	<p>AD 1</p>			<p>Flash</p>			<p>Steady</p>																																																																				
	<p>CO 6</p>						<p>Binary Data</p>			<p>Binary Data</p>																																																																	
	<p>CO 4</p>						<p>Binary Data</p>			<p>Binary Data</p>																																																																	
	<p>CO 2</p>						<p>Binary Data</p>			<p>Binary Data</p>																																																																	
<p>INT</p>						<p>Binary Data</p>			<p>Binary Data</p>																																																																		
<p>NOTES:</p>																																																																											
<p>1. Depressing the # key displays the data without changing it. The first # will display the first digit; the second # will display the second digit, etc.</p>																																																																											
<p>2. To clear existing data without entering a new number, depress the # key two times.</p>																																																																											
<table border="1"> <tr> <td colspan="2">Binary Numbers:</td> <td>1</td><td>2</td><td>3</td><td>4</td><td>5</td><td>6</td><td>7</td><td>8</td><td>9</td><td>0</td><td>DND</td> </tr> <tr> <td rowspan="4">X = LED on All LEDs off = no data</td> <td>CO 6</td> <td></td><td></td><td></td><td></td><td></td><td></td><td></td><td>X</td><td>X</td><td>X</td><td>X</td> </tr> <tr> <td>CO 4</td> <td></td><td></td><td></td><td>X</td><td>X</td><td>X</td><td>X</td><td></td><td></td><td></td><td>X</td> </tr> <tr> <td>CO 2</td> <td></td><td>X</td><td>X</td><td></td><td></td><td>X</td><td>X</td><td></td><td></td><td>X</td><td></td> </tr> <tr> <td>INT</td> <td>X</td><td></td><td>X</td><td></td><td>X</td><td></td><td>X</td><td></td><td>X</td><td></td><td>X</td> </tr> </table>														Binary Numbers:		1	2	3	4	5	6	7	8	9	0	DND	X = LED on All LEDs off = no data	CO 6								X	X	X	X	CO 4				X	X	X	X				X	CO 2		X	X			X	X			X		INT	X		X		X		X		X		X
Binary Numbers:		1	2	3	4	5	6	7	8	9	0	DND																																																															
X = LED on All LEDs off = no data	CO 6								X	X	X	X																																																															
	CO 4				X	X	X	X				X																																																															
	CO 2		X	X			X	X			X																																																																
	INT	X		X		X		X		X		X																																																															
<p>5) Depress the HOLD key to place new data in memory.</p>	<p>All station 17 LEDs (except REP) go off.</p>																																																																										
<p>6A) Return to Step 2 in order to continue with this program or 6B) Go to Step 2 in another program table or 6C) Transfer data into working memory per Paragraph 02.06.</p>	<p>SET LED goes off. Station 17 REP LED goes off. New data is stored, previous data is erased.</p>																																																																										

TABLE 30
PROGRAM 3XX
STATION CO LINE ACCESS

<p>1) Lock in the SET switch on the HKSU.</p>	<p>SET LED on. Station 17 REP LED on. System is in program mode. Normal functions halt on station 17.</p>
<p>2) Depress the SPKR key on station 17.</p>	<p>SPKR LED steady on.</p>
<p>3) Dial 3 X X on the dial pad. XX = the number of the station(s) to be programmed. <i>NOTE:</i> <i>For multiple station programming, refer to Paragraph 02.12.</i></p>	<p>SPKR LED flashes continuously. CO LEDs go on according to present data.</p>
<p>4) Refer to the System Record Sheet. Using the CO keys, turn their associated LEDs on or off, as required.</p> <ul style="list-style-type: none"> • LED on = Access allowed. • Each CO key/LED represents itself—that is, if the CO 1 LED is on, then the station being programmed (XX) is allowed access to CO 1, etc. 	<p>An X on the record sheet means the LED should be on. If the LED is already on, depressing its associated key will turn it off and vice versa. LEDs may be turned off and on until the desired pattern is set.</p>
<p>5) Depress the HOLD key to place new data in memory.</p>	<p>All station 17 LEDs (except REP) go off.</p>
<p>6A) Return to Step 2 in order to continue with this program ... or ... 6B) Go to Step 2 in another program table ... or ... 6C) Transfer data into working memory per Paragraph 02.06.</p>	<p>SET LED goes off. Station 17 REP LED goes off. New data is stored, previous data is erased.</p>

TABLE 31
PROGRAM 4XX
STATION TYPE ASSIGNMENT

<p>1) Lock in the SET switch on the HKSU.</p>	<p>SET LED on. Station 17 REP LED on. System is in program mode. Normal functions halt on station 17.</p>
<p>2) Depress the SPKR key on station 17.</p>	<p>SPKR LED steady on.</p>
<p>3) Dial 4 X X on the dial pad. XX = the number of the station(s) to be programmed. <i>NOTE:</i> <i>For multiple station programming, refer to Paragraph 02.12.</i></p>	<p>SPKR LED flashes continuously. CO LEDs go on according to present data.</p>
<p>4) Refer to the System Record Sheet. Using the CO keys, turn their associated LEDs on or off, as required.</p>	<p>An X on the record sheet means the LED should be on. If the LED is already on, depressing its associated key will turn it off and vice versa. LEDs may be turned off and on until the desired pattern is set.</p>
<p>5) Depress the HOLD key to place new data in memory.</p>	<p>All station 17 LEDs (except REP) go off.</p>
<p>6A) Return to Step 2 in order to continue with this program ... or ... 6B) Go to Step 2 in another program table ... or ... 6C) Transfer data into working memory per Paragraph 02.06.</p>	<p>SET LED goes off. Station 17 REP LED goes off. New data is stored, previous data is erased.</p>

TABLE 32
PROGRAM 4#XX
STATION FLEXIBE KEY ASSIGNMENT

1) Lock in the SET switch on the HKSU.	SET LED on. Station 17 REP LED on. System is in program mode. Normal functions halt on station 17.
2) Depress the SPKR key on station 17.	SPKR LED steady on.
3) Dial 4 # X X on the dial pad. XX = the number of the station(s) to be programmed. <i>NOTE:</i> <i>For multiple station programming, refer to Paragraph 02.12.</i>	SPKR LED flashes continuously.
4) Refer to the System Record Sheet. Depress the key to be programmed. IMPORTANT! A 20-key LCD EKT is highly recommended for this procedure.	The present feature's code number for that key will be displayed by the LCD.
5) Dial in the new feature's number. The detailed meaning of each feature code is shown below.	The new feature's number will be displayed on the LCD.
6) Continue to return to Step 4 until all desired features for chosen station(s) are programmed.	
7) Depress the HOLD key to place new data in memory.	All station 17 LEDs (except REP) go off.
8A) Return to Step 2 in order to continue with this program for additional station(s) ... or ... 8B) Go to Step 2 in another program table ... or ... 8C) Transfer data into working memory per Paragraph 02.06.	SET LED goes off. Station 17 REP LED goes off. New data is stored, previous data is erased.

NOTE:

All codes can only be assigned once per EKT. If assigned more than once, keys become AD keys.

CODE	DESCRIPTION	CODE	DESCRIPTION	CODE	DESCRIPTION
01	CO1	83	CPU1	92XXX	DSS1
02	CO2	84	CPU	93	PRV
03	CO3	85	SAVE	94	ACB
04	CO4	86	DRLK	95	PAU
05	CO5	87	CFD	96	RDL
06	CO6	88	MCO	97	REP
*	ADL1	90	TONE	98	DND
82	CPU2	91XX	DSS1	99	MW/FL

**TABLE 33
PROGRAM 5XX
STATION CLASS OF SERVICE #1**

<p>1) Lock in the SET switch on the HKSU.</p>	<p>SET LED on. Station 17 REP LED on. System is in program mode. Normal functions halt on station 17.</p>
<p>2) Depress the SPKR key on station 17.</p>	<p>SPKR LED steady on.</p>
<p>3) Dial 5 X X on the dial pad. XX = the number of the station(s) to be programmed. <i>NOTE: For multiple station programming, refer to Paragraph 02.12.</i></p>	<p>SPKR LED flashes continuously. CO LEDs go on according to present data.</p>
<p>4) Refer to the System Record Sheet. Using the CO keys, turn their associated LEDs on or off, as required.</p>	<p>An X on the record sheet means the LED should be on. If the LED is already on, depressing its associated key will turn it off and vice versa. LEDs may be turned off and on until the desired pattern is set.</p>
<p>5) Depress the HOLD key to place new data in memory.</p>	<p>All station 17 LEDs (except REP) go off.</p>
<p>6A) Return to Step 2 in order to continue with this program ... or ... 6B) Go to Step 2 in another program table ... or ... 6C) Transfer data into working memory per Paragraph 02.06.</p>	<p>SET LED goes off. Station 17 REP LED goes off. New data is stored, previous data is erased.</p>

TABLE 34
PROGRAM 5#XX
STATION CLASS OF SERVICE #2

<p>1) Lock in the SET switch on the HKSU.</p>	<p>SET LED on. Station 17 REP LED on. System is in program mode. Normal functions halt on station 17.</p>
<p>2) Depress the SPKR key on station 17.</p>	<p>SPKR LED steady on.</p>
<p>3) Dial 5 # X X on the dial pad. XX = the number of the station(s) to be programmed. <i>NOTE:</i> <i>For multiple station programming, refer to Paragraph 02.12.</i></p>	<p>SPKR LED flashes continuously. CO LEDs go on according to present data.</p>
<p>4) Refer to the System Record Sheet. Using the CO keys, turn their associated LEDs on or off, as required.</p>	<p>An X on the record sheet means the LED should be on. If the LED is already on, depressing its associated key will turn it off and vice versa. LEDs may be turned off and on until the desired pattern is set.</p>
<p>5) Depress the HOLD key to place new data in memory.</p>	<p>All station 17 LEDs (except REP) go off.</p>
<p>6A) Return to Step 2 in order to continue with this program ... or ... 6B) Go to Step 2 in another program table ... or ... 6C) Transfer data into working memory per Paragraph 02.06.</p>	<p>SET LED goes off. Station 17 REP LED goes off. New data is stored, previous data is erased.</p>

TABLE 35
PROGRAM 6XX
STATION TOLL RESTRICTION CLASS

<p>1) Lock in the SET switch on the HKSU.</p>	<p>SET LED on. Station 17 REP LED on. System is in program mode. Normal functions halt on station 17.</p>				
<p>2) Depress the SPKR key on station 17.</p>	<p>SPKR LED steady on.</p>				
<p>3) Dial 6 XX on the dial pad. XX = the number of the station(s) to be programmed. <i>NOTE:</i> <i>For multiple station programming, refer to Paragraph 02.12.</i></p>	<p>SPKR LED flashes continuously. CO LEDs go on according to present data.</p>				
<p>4) Refer to the System Record Sheet. Using the CO keys, turn their associated LEDs on or off, as required. The detailed meaning of each key/LED is shown below.</p>	<p>An X on the record sheet means the LED should be on. If the LED is already on, depressing its associated key will turn it off and vice versa. LEDs may be turned off and on until the desired pattern is set.</p>				
	<p>KEY/LED</p>	<p>FEATURE</p>	<p>LED ON</p>	<p>LED OFF</p>	
	CO6	Class 4*	Selected	None	
	CO5	Class 3*	Selected	None	
	CO4	Class 2*	Selected	None	
	CO3	Class 1*	Selected	None	
	CO2	Restrict 0 or 1 as 1st and 2nd digit	Selected	None	
	CO1	Allow 1 + Office Code only	Selected	None	
	INT	No restriction	Selected	—	
<p>5) Depress the HOLD key to place new data in memory.</p>	<p>All station 17 LEDs (except REP) go off.</p>				
<p>6A) Return to Step 2 in order to continue with this program ... or ... 6B) Go to Step 2 in another program table ... or ... 6C) Transfer data into working memory per Paragraph 02.06.</p>	<p>SET LED goes off. Station 17 REP LED goes off. New data is stored, previous data is erased.</p>				

* See Toll Restriction Programs 100, 1X1, 1XY, 1XZ and 2XY.

TABLE 36
PROGRAM 7XX
STATION OUTGOING CALL RESTRICTION

<p>1) Lock in the SET switch on the HKSU.</p>	<p>SET LED on. Station 17 REP LED on. System is in program mode. Normal functions halt on station 17.</p>
<p>2) Depress the SPKR key on station 17.</p>	<p>SPKR LED steady on.</p>
<p>3) Dial 7 X X on the dial pad. XX = the number of the station(s) to be programmed. <i>NOTE:</i> <i>For multiple station programming, refer to Paragraph 02.12.</i></p>	<p>SPKR LED flashes continuously. CO LEDs indicate present data.</p>
<p>4) Refer to the System Record Sheet. Using the CO keys, turn their associated LEDs on or off, as required.</p> <ul style="list-style-type: none"> ● LED on = Restricted outgoing calls. ● Each CO key/LED represents itself—that is, if CO1 LED is on, then the station being programmed (XX) is restricted from outgoing calls on CO1, etc. 	<p>An X on the record sheet means the LED should be on. If the LED is already on, depressing the associated key will turn it off and vice versa. LEDs may be turned off and on until the desired pattern is set.</p>
<p>5) Depress the HOLD key to place new data in memory.</p>	<p>All station 17 LEDs (except REP) go off. New data is stored, previous data is erased.</p>
<p>6A) Return to Step 2 in order to continue with this program ... or ... 6B) Go to Step 2 in another program table ... or ... 6C) Transfer data into working memory per Paragraph 02.06.</p>	<p>SET LED goes off. Station 17 REP LED goes off.</p>

TABLE 37
PROGRAM 8XX
CO RINGING ASSIGNMENTS-DAY

<p>1) Lock in the SET switch on the HKSU.</p>	<p>SET LED on. Station 17 REP LED on. System is in program mode. Normal functions halt on station 17.</p>
<p>2) Depress the SPKR key on station 17.</p>	<p>SPKR LED steady on.</p>
<p>3) Dial 3 XX on the dial pad. XX = the number of the station(s) to be programmed. <i>NOTE:</i> <i>For multiple station programming, refer to Paragraph 02.12.</i></p>	<p>SPKR LED flashes continuously. CO LEDs indicate present data.</p>
<p><i>NOTES:</i></p> <ol style="list-style-type: none"> 1. Any station(s) designated to ring must be allowed access via Program 3XX. 2. A maximum of eight stations may be assigned to ring for any given CO line. If more are assigned, the lowest eight station numbers will ring—the others will be ignored. 	
<p>4) Refer to the System Record Sheet. Using the CO keys, turn their associated LEDs on or off, as required.</p> <ul style="list-style-type: none"> • LED on = Ring in DAY mode. • Each CO key/LED represents itself—that is, if CO 1 LED is on, then the station being programmed (XX) will ring when a call comes in on CO 1 in the DAY mode, etc. 	<p>An X on the record sheet means the LED should be on. If the LED is already on, depressing its associated key will turn it off and vice versa. LEDs may be turned off and on until the desired pattern is set.</p>
<p>5) Depress the HOLD key to place new data in memory.</p>	<p>All station 17 LEDs (except REP) go off. New data is stored, previous data is erased.</p>
<p>6A) Return to Step 2 in order to continue with this program ... or ... 6B) Go to Step 2 in another program table ... or ... 6C) Transfer data into working memory per Paragraph 02.06.</p>	<p>SET LED goes off. Station 17 REP LED goes off.</p>

TABLE 38
PROGRAM 8#XX
CO RINGING ASSIGNMENTS-DAY 2

<p>1) Lock in the SET switch on the HKSU.</p>	<p>SET LED on. Station 17 REP LED on. System is in program mode. Normal functions halt on station 17.</p>
<p>2) Depress the SPKR key on station 17.</p>	<p>SPKR LED steady on.</p>
<p>3) Dial 8 # X X on the dial pad. XX = the number of the station(s) to be programmed. <i>NOTE:</i> <i>For multiple station programming, refer to Paragraph 02.12.</i></p>	<p>SPKR LED flashes continuously. CO LEDs indicate present data.</p>
<p><i>NOTES:</i> 1. Any station(s) designated to ring must be allowed access via Program 3XX. 2. A maximum of eight stations may be assigned to ring for any given CO line. If more are assigned, the lowest eight station numbers will ring—the others will be ignored.</p>	
<p>4) Refer to the System Record Sheet. Using the CO keys, turn their associated LEDs on or off, as required.</p> <ul style="list-style-type: none"> • LED on = Ring in DAY 2 mode. • Each CO key/LED represents itself—that is, if CO 1 LED is on, then the station being programmed (XX) will ring when a call comes in on CO 1 in the DAY 2 mode, etc. 	<p>An X on the record sheet means the LED should be on. If the LED is already on, depressing its associated key will turn it off and vice versa. LEDs may be turned off and on until the desired pattern is set.</p>
<p>5) Depress the HOLD key to place new data in memory.</p>	<p>All station 17 LEDs (except REP) go off. New data is stored, previous data is erased.</p>
<p>6A) Return to Step 2 in order to continue with this program ... or ... 6B) Go to Step 2 in another program table ... or ... 6C) Transfer data into working memory per Paragraph 02.06.</p>	<p>SET LED goes off. Station 17 REP LED goes off.</p>

TABLE 39
PROGRAM 9XX
CO RINGING ASSIGNMENTS-NITE

<p>1) Lock in the SET switch on the HKSU.</p>	<p>SET LED on. Station 17 REP LED on. System is in program mode. Normal functions halt on station 17.</p>
<p>2) Depress the SPKR key on station 17.</p>	<p>SPKR LED steady on.</p>
<p>3) Dial 9 XX on the dial pad. XX = the number of the station(s) to be programmed. <i>NOTE:</i> <i>For multiple station programming, refer to Paragraph 02.12.</i></p>	<p>SPKR LED flashes continuously. CO LEDs indicate present data.</p>
<p><i>NOTES:</i></p> <ol style="list-style-type: none"> 1. Any station(s) designated to ring must be allowed access via Program 3XX. 2. A maximum of eight stations may be assigned to ring for any given CO line. If more are assigned, the lowest eight station numbers will ring—the others will be ignored. 	
<p>4) Refer to the System Record Sheet. Using the CO keys, turn their associated LEDs on or off, as required.</p> <ul style="list-style-type: none"> • LED on = Ring in NITE mode. • Each CO key/LED represents itself—that is, if CO 1 LED is on, then the station being programmed (XX) will ring when a call comes in on CO 1 in the NITE mode, etc. 	<p>An X on the record sheet means the LED should be on. If the LED is already on, depressing its associated key will turn it off and vice versa. LEDs may be turned off and on until the desired pattern is set.</p>
<p>5) Depress the HOLD key to place new data in memory.</p>	<p>All station 17 LEDs (except REP) go off. New data is stored, previous data is erased.</p>
<p>6A) Return to Step 2 in order to continue with this program ... or ... 6B) Go to Step 2 in another program table ... or ... 6C) Transfer data into working memory per Paragraph 02.06.</p>	<p>SET LED goes off. Station 17 REP LED goes off.</p>

***Strata[®] VI_e*
SYSTEM RECORD**

APPENDIX 1

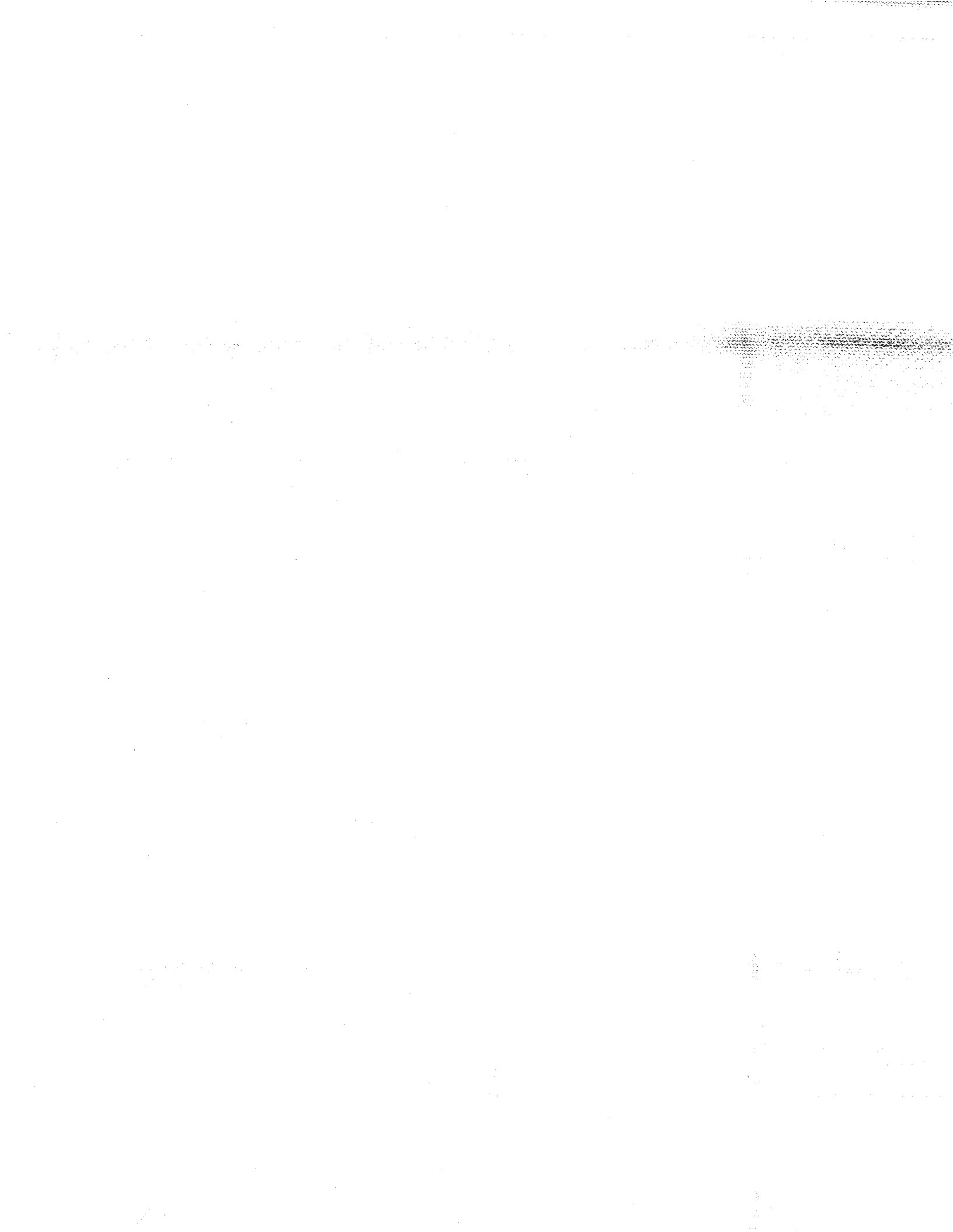

TABLE 1
SYSTEM RECORD SHEET
PROGRAM 01-SYSTEM ASSIGNMENTS (Basic)

KEY/LED	X	LED ON	LED OFF
PAU		Transfer Privacy	Alternate point answer of transferred CO line
AD7		System Speed Dial Override Toll Restriction	Restricted
AD6		Four CO Line Groups (91 ~ 94)	One CO Line Group (9)
AD5		Two CO Conferencing—Inhibit	Allowed
AD3		DP Make Ratio 33%	40%
AD2		MF Signal Time 160ms	80ms
MW/FL		Non-Privacy	Privacy
ACB		Station 17/10-key EKT	Station 17/20-key EKT
CO6		Incoming Call Abandon (8 seconds)	6 seconds
CO5		3-sec. Pause After Flash	1.5-sec. Pause
CO4		Insert Pause After Flash	No Pause
CO3		3-sec. Pause (<input type="checkbox"/> MW/FL or <input type="checkbox"/> PAU key)	1.5 sec. Pause
CO 2		0.5-sec. Flash Timing	2.0-sec. Flash
INT		Tone First	Voice First

X = Select (LED on) Initialized Data: All LEDs off

PROGRAM 02—SYSTEM ASSIGNMENTS (Options)

KEY/LED	X	LED ON	LED OFF
DND		OPX#21 Busy	Not busy
CO4		Display the dialed number (1 minute)	15 seconds
CO2		Night Ring over External Page Allowed	Not Allowed
CO1		BGM over External Page Allowed	Not Allowed
INT		External Page Included with All Call Page	Not Included

Initialized Data: All LEDs off

PROGRAM 0#2—ACCOUNT CODE DIGIT LENGTH (4 to 15 digit length)

--	--

Initialized Data: 6 digits

PROGRAM 03-SYSTEM ASSIGNMENTS (Options)

KEY/LED	X	LED ON	LED OFF
PAU		Door Lock Time (6 seconds)	3 seconds
AD7		Door Phone C/Alarm	Door Phone
AD6		Door Phone B/Door Lock	Door Phone
AD5		Door Phone C Busy	Door Phone
AD4		Door Phone B Busy	Door Phone
AD3		Station #14 is Door Phone	Station #14 is EKT
AD2		Station #13 is Door Phone	Station #13 is EKT
AD1		Station #10 Alarm Key	AD 1 Key
MW/FL		Station #10 DND Key	Nite Key
DND		3-Ring Mode	2-Ring Mode
CO4		Message Center Station #12	Not Equipped
CO3		Message Center Station #11	Not Equipped
CO2		Message Center Station #10	Not Equipped

Initialized Data: CO2 on; all other LEDs off

PROGRAM 04—VCOU OUTPUTS

KEY/LED	X	LED ON	LED OFF
CO6		DP	MF
CO5		DP	MF
CO4		DP	MF
CO3		DP	MF
CO2		DP	MF
CO1		DP	MF

Initialized Data: All LEDs off

PROGRAM 05
AUTOMATIC RECALL FROM HOLD TIMING

KEY/LED	X	TIME
ACB		160 seconds
CO6		128 seconds
CO5		96 seconds
CO4		64 seconds
CO3		48 seconds
CO2		32 seconds
CO1		16 seconds
INT		No Recall

X = Select (LED on). Initialized Data: CO2 LED on

NOTE:

Used only if AD1, AD2 & AD3 LEDs in Program 5#XX are all off.

PROGRAM 0#5
CAMP-ON TIMEOUT

KEY/LED	X	TIME
CO3		64 seconds
CO2		48 seconds
CO1		32 seconds
INT		16 seconds

X = Select (LED on) Initialized Data: CO 1 LED on

PROGRAM 06
AUTOMATIC RELEASE ON HOLD ENABLE

KEY/LED	X
CO6	
CO5	
CO4	
CO3	
CO2	
CO1	

X = Enable (LED on)
 Initialized Data: All LEDs off

PROGRAM 07
AUTOMATIC RELEASE ON HOLD TIMING

KEY/LED	X
CO6	
CO5	
CO4	
CO3	
CO2	
CO1	

X = XB (LED on) Blank = ESS
 Initialized Data: All LEDs off

PROGRAM 0#8—NIGHT RING OVER EXTERNAL PAGE

KEY/LED	X	LED ON	LED OFF
CO6		Ring	No Ring
CO5		Ring	No Ring
CO4		Ring	No Ring
CO3		Ring	No Ring
CO2		Ring	No Ring
CO1		Ring	No Ring

Initialized Data: All LEDs off

NOTE:
Program 02 CO2 LED on.

PROGRAM 09
SINGLE CO LINE (DIAL 9)
GROUP SELECTION (OPX, Trunk Queuing)

KEY/LED	X
CO6	X
CO5	X
CO4	X
CO3	X
CO2	X
CO1	X

X = Include in "Dial 9" group (LED on)
 Initialized Data: All LEDs on

NOTE:
 Used only if AD6 LED is off in Program 01
 (Single CO Line Group).

PROGRAM 09X
FOUR CO LINE GROUP SELECTION
(Dial 91, 92, 93, 94—OPX, Trunk Queuing)

CO LINE	GROUP			
	091	092	093	094
CO6	X			
CO5	X			
CO4	X			
CO3	X			
CO2	X			
CO1	X			

X = Include in group (LED on)
 Initialized Data:

091—All LEDs on 092 ~ 094—All LEDs off

**NOTE:*
 Used only if AD6 LED is on in Program 01
 (Four CO Line Groups).

PROGRAM 0#9
OPL LINE HUNTING (HOLB)

KEY/LED	X
CO6	X
CO5	X
CO4	X
CO3	X
CO2	X
CO1	X

X = Hunting
 Initialized Data: All LEDs on

PROGRAM 100—TOLL RESTRICTION SYSTEM PARAMETERS
(Dialing Plan)

KEY/LED	X	LED ON	LED OFF
CO2		1 + A/C + NXX and NXX	
CO1		1 + A/C + NNX and 1 + NNX	
INT		A/C + NNX and 1 + NNX	

Initialized Data: INT LED on

PROGRAM 101—TOLL RESTRICTION DISABLE

KEY/LED	X	LED ON	LED OFF
CO6		Disable	Enable
CO5		Disable	Enable
CO4		Disable	Enable
CO3		Disable	Enable
CO2		Disable	Enable
CO1		Disable	Enable

Initialized Data: All LEDs off

PROGRAM 102—FORCED ACCOUNT CODE CHECK

KEY/LED	X	LED ON	LED OFF
CO6		Check	No Check
CO5		Check	No Check
CO4		Check	No Check
CO3		Check	No Check
CO2		Check	No Check
CO1		Check	No Check

Initialized Data: All LEDs off

NOTE:
Program 0#2 defines number of digits in account code.

**PROGRAMS 103, 104, 105 & 106
 EQUAL ACCESS NUMBERS 1 & 2
 OCC AUTHORIZATION CODE LENGTHS (1 & 2)**

PROGRAM	ITEM	ENTRY
103	Equal Access* Number 1	
104	OCC Authorization** Code Digit Length #1	
105	Equal Access* Number 2	
106	OCC Authorization** Code Digit Length #2	

X = 0 ~ 9

*Enter the equal access code or Other Common Carrier directory number (five digits: 10XXX).

**Enter the number of digits in the OCC Authorization Code (00 ~ 16).

PROGRAM 1X0—TOLL RESTRICTION CLASS PARAMETERS

X = class 1 ~ 4

KEY/LED	X	LED ON	LED OFF
CO2		Area Code + 555 + XXXX Allowed	Not Allowed
CO1		"01" or "011" Overseas Restricted	Allowed
INT		"0" + Restricted	Allowed

Initialized Data: All LEDs off

PROGRAM 1X1—TOLL RESTRICTION CLASS
AREA/OFFICE CODE EXCEPTION TABLE SELECTION

X = class 1 ~ 4

KEY/LED	X	LED ON	LED OFF
ACB		Area/Office Code Table 8 selected	Not Selected
CO6		Area/Office Code Table 7 selected	Not Selected
CO5		Area/Office Code Table 6 selected	Not Selected
CO4		Area/Office Code Table 5 selected	Not Selected
CO3		Area/Office Code Table 4 selected	Not Selected
CO2		Area/Office Code Table 3 selected	Not Selected
CO1		Area/Office Code Table 2 selected	Not Selected
INT		Area/Office Code Table 1 selected	Not Selected

Initialized Data: All LEDs off

NOTE: Use multiple sheets as required. Sheet _____ of _____.

**PROGRAM 190
 PBX BACKUP**

CO LINE	X
CO6	
CO5	
CO4	
CO3	
CO2	
CO1	

X = Connected to PBX line
 (LED on)

Initialized Data: All LEDs off

**PROGRAM 19X
 PBX ACCESS CODES**

CODES	1st DIGIT	2nd DIGIT
#1 (191)		
#2 (192)		
#3 (193)		
#4 (194)		
#5 (195)		
#6 (196)		
#7 (197)		
#8 (198)		

Enter the Access Codes (Maximum: 8)
 Initialized Data: AD1 flashing

NOTE:

If the access code is a single digit, enter "*" in the second column. If all combinations following a particular 1st digit are to be considered access codes (e.g., 91, 92, 93, etc.), enter "D" (don't care) in the 2nd column.

PROGRAM 3XX—STATION CO LINE ACCESS

KEY/LED	FEATURE	STATION NUMBERS																								
		10	11	12	13	14	15	16	17	18	19	20	21	22	23	24	25									
CO6	Allow Access																									
CO 5	Allow Access																									
CO 4	Allow Access																									
CO 3	Allow Access																									
CO 2	Allow Access																									
CO 1	Allow Access																									

X = Select (LED on) Initialized Data: All LEDs on

PROGRAM 4XX—STATION TYPE ASSIGNMENT

KEY/LED	FEATURE	STATION NUMBERS																								
		10	11	12	13	14	15	16	17	18	19	20	21	22	23	24	25									
AD2	Start at CO4																									
AD1	Start at CO1																									
MW/FL	Top to Bottom																									
CO1	10-key																									
INT	20-key																									

XX = Station number

Initialized Data: CO1 and AD1 LEDs on; all other LEDs off

PROGRAM 4#XX—STATION FLEXIBLE KEY ASSIGNMENTS

STATION KEY								
19								
18								
17								
16								
15								
14								
13								
12								
11								
10								
9								
8								
7								
6								
5								
4								
3								
2								
1								
0	INT	INT	INT	INT	INT	INT	INT	INT

NOTES:

1. Each code (except * for AD) can only be assigned once per EKT. If assigned more than once, keys become AD keys. Refer to Table 32 for feature codes.
2. Use multiple sheets as required. Sheet _____ of _____.

PROGRAM 5XX—STATION CLASS OF SERVICE #1

KEY/LED	FEATURE	STATION NUMBERS																								
		10	11	12	13	14	15	16	17	18	19	20	21	22	23	24	25									
PAU	Privacy Override Allowed																									
AD7	DND Override Allowed [2]																									
AD6	Executive Override Allowed [3]																									
AD3	Door Phone C ring																									
AD2	Door Phone B ring																									
AD1	Door Phone A ring																									
MW/FL	Group Page 4																									
DND	Group Page 3																									
ACB	Group Page 2																									
CO6	Group Page 1																									
CO5	All Call Page Allowed																									
CO4	Room Monitor without Warning Tone																									
CO3	Handsfree Answerback Allowed																									
CO2	MIC on at start of call																									
CO1	MIC key lock																									
INT	Speakerphone Enable																									

Initialized Data: INT and CO5 LEDs on; all other LEDs off

PROGRAM 5#XX—STATION CLASS OF SERVICE #2

KEY/LED	FEATURE	STATION NUMBERS																								
		10	11	12	13	14	15	16	17	18	19	20	21	22	23	24	25									
AD7	Station-to-Station Message Waiting with LCD Allowed																									
AD5	Forced Account Code required																									
AD3	Hold Recall Time Code*																									
AD2	Hold Recall Time Code*																									
AD1	Hold Recall Time Code*																									
ACB	Automatic off-hook selection; Group 94 or 9 (see NOTE)																									
CO6	Automatic off-hook selection; Group 93 or 9 (see NOTE)																									
CO5	Automatic off-hook selection; Group 92 or 9 (see NOTE)																									
CO4	Automatic off-hook selection; Group 91 or 9 (see NOTE)																									
CO3	Automatic off-hook selection; CO1 Position																									
CO2	Automatic off-hook selection; INT																									
CO1	Ringin Line Preference																									
INT	Automatic Dialing Allowed																									

Initialized Data: AD7, CO1, INT LEDs on; all other LEDs off

NOTE:
Only one selection possible per station; lowest selection has priority.

***Hold Recall Time Code**

KEY/LED	Prog. 05	16 Sec.	32 Sec.	48 Sec.	64 Sec.	96 Sec.	128 Sec.	160 Sec.
AD3					X	X	X	X
AD2			X	X			X	X
AD1		X		X		X		X

PROGRAM 6XX—STATION TOLL RESTRICTION CLASS

KEY/LED	FEATURE	STATION NUMBERS																								
		10	11	12	13	14	15	16	17	18	19	20	21	22	23	24	25									
CO6	Class 4*																									
CO5	Class 3*																									
CO4	Class 2*																									
CO3	Class 1*																									
CO2	Restrict 0 or 1, 1st and 2nd digit																									
CO1	Allow 1 + O/C only																									
INT	No restriction																									

Initialized Data: INT LED on; all other LEDs off

* See Toll Restriction Programs 100, 1X1, 1XY, 1XZ and 2XY.

PROGRAM 7XX—STATION OUTGOING CALL RESTRICTION

KEY/LED	FEATURE	STATION NUMBERS																								
		10	11	12	13	14	15	16	17	18	19	20	21	22	23	24	25									
CO 6	Restricted																									
CO 5	Restricted																									
CO 4	Restricted																									
CO 3	Restricted																									
CO 2	Restricted																									
CO 1	Restricted																									

X = Select (LED on) Initialized Data: All LEDs off

PROGRAM 8XX—CO RINGING ASSIGNMENTS-DAY

KEY/LED	FEATURE	STATION NUMBERS																								
		10	11	12	13	14	15	16	17	18	19	20	21	22	23	24	25									
CO 6	Ring in DAY																									
CO 5	Ring in DAY																									
CO 4	Ring in DAY																									
CO 3	Ring in DAY																									
CO 2	Ring in DAY																									
CO 1	Ring in DAY																									

X = Select (LED on) Initialized Data: Station 10—all LEDs on; all other LEDs off
NOTE:

Each line can ring on only eight stations. If more than eight are programmed, only the eight stations with the lowest station numbers will ring.

PROGRAM 8#XX—CO RINGING ASSIGNMENTS-DAY 2

KEY/LED	FEATURE	STATION NUMBERS																								
		10	11	12	13	14	15	16	17	18	19	20	21	22	23	24	25									
CO 6	Ring in DAY 2																									
CO 5	Ring in DAY 2																									
CO 4	Ring in DAY 2																									
CO 3	Ring in DAY 2																									
CO 2	Ring in DAY 2																									
CO 1	Ring in DAY 2																									

X = Select (LED on) Initialized Data: All LEDs off

NOTE:

Each line can ring on only eight stations. If more than eight are programmed, only the eight stations with the lowest station numbers will ring.

PROGRAM 9XX—CO RINGING ASSIGNMENTS-NIGHT

KEY/LED	FEATURE	STATION NUMBERS															
		10	11	12	13	14	15	16	17	18	19	20	21	22	23	24	25
CO 6	Ring in NIGHT																
CO 5	Ring in NIGHT																
CO 4	Ring in NIGHT																
CO 3	Ring in NIGHT																
CO 2	Ring in NIGHT																
CO 1	Ring in NIGHT																

X = Select (LED on) Initialized Data: Station 10—all LEDs on; all other LEDs off
NOTE:
Each line can ring on only eight stations. If more than eight are programmed, only the eight stations with the lowest station numbers will ring.

TB 000-8603
November 1, 1986

Page 1 of 1

Carbon Handset Installation

All 6000-series electronic key telephones (EKTs) are factory-equipped with dynamic handsets. If a carbon handset is desired, an EKT modification is necessary. With the exception of the Single-Line EKT, the following modification is applicable to all 6000-series EKTs.

- 1) Remove the four screws holding the EKT base cover.
- 2) Remove the base cover.
- 3) On the exposed PCB, cut jumpers **W2** and **W3** (also marked "CARBON"). See Figure 1.

NOTE:

Figure 1 shows the locations of the **W2** and **W3** jumpers for both handsfree answerback (HFU) and speakerphone (SPF) EKTs.

- 4) Reinstall the base cover and its four screws.
- 5) Replace the dynamic handset with the carbon handset.

