

**Panasonic**  
ideas for life



## Digital Proprietary Telephones

### Quick Reference Guide

**MODELS**  
KX-DT343  
KX-DT346





<KX-DT346>

# Panasonic®

Digital Proprietary Telephones

## Quick Reference Guide

Model **KX-DT343**  
**KX-DT346**

### ***Important Information***

---

**When using the KX-DT300 series, keep the following conditions in mind.**

- If there is any problem, unplug the extension line and connect a known working phone. If the known working phone operates properly, have the defective phone repaired by a specified Panasonic Factory Service Centre. If the known working phone does not operate properly, check the Panasonic Phone System series Business Telephone Systems and the internal extension wiring.
- Keep the unit away from heating appliances and electrical noise generating devices such as fluorescent lamps, motors and televisions. These noise sources can interfere with the performance of the unit.
- This unit should be kept free of dust, moisture, high temperature (more than 40 °C) and vibration, and should not be exposed to direct sunlight.
- Do not use benzine, thinner, or similar products, or any abrasive powder to clean the cabinet. Wipe it with a soft cloth.
- Do not use any handset other than a Panasonic handset.
- Do not disassemble this product. Dangerous electrical shock could result. The unit must only be disassembled and repaired by qualified service technicians.
- When a failure occurs, which exposes any internal parts, disconnect the telephone line cord immediately and return this unit to service centre.
- Never attempt to insert wires, pins, etc, into the vents or other holes of this unit.

#### **WARNING:**

**TO PREVENT THE RISK OF FIRE OR ELECTRIC SHOCK, DO NOT EXPOSE THIS PRODUCT TO RAIN OR MOISTURE.**

**THIS HANDSET EARPIECE IS MAGNETISED AND MAY RETAIN SMALL FERROUS OBJECTS.**

#### **IMPORTANT NOTICE:**

- Under power failure conditions, this telephone may not operate. Please ensure that a separate telephone, not dependent on local power, is available for use in an emergency.
- This Class B digital apparatus complies with Canadian ICES-003.

#### **Note:**

- In this manual, the suffix of each model number is omitted.
- Displays are described in English as samples.

# Table of Contents



<b>Features for the Digital Proprietary Telephones.....</b>	Setting Features .....	10
<b>4</b>	<b>Location of Controls .....</b>	<b>12</b>
<b>Features List .....</b>	<b>Setting .....</b>	<b>14</b>
<b>5</b>	<b>Connection.....</b>	<b>15</b>
<b>Using the Display Proprietary Telephone..</b>	<b>Wall Mounting .....</b>	<b>16</b>
<b>7</b>	<b>Installing the KX-DT301/KX-NT303.....</b>	<b>17</b>
Using the Call Log or Directories .....		
7		
Accessing the System Features .....		
8		
<b>Settings on the Programming Mode.....</b>		
<b>10</b>		

## Before Initial Use

Thank you for purchasing a Panasonic Digital Proprietary Telephone (DPT). Please read this manual carefully before using this product and save this manual for future use. For more details, please refer to the manuals of the PBX.

**Note:** In this manual, the suffix of each model number is omitted unless necessary.

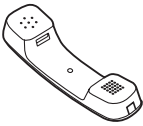
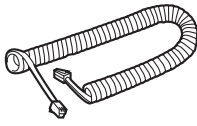
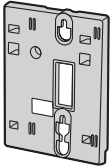
## Accessories (included)

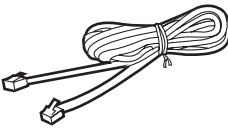
<input type="checkbox"/> Handset: 1  	<input type="checkbox"/> Handset Cord: 1  	<input type="checkbox"/> Wall Mounting Adaptor*1: 1  
<input type="checkbox"/> Screws for wall: 2  	<input type="checkbox"/> Telephone Line Cord: 1  	

\*1 This telephone comes with the wall mounting adaptor already attached. To remove the adaptor, refer to step 1 on page 16.

## ***Features for the Digital Proprietary Telephones***

This unit supports the following optional devices and features:

	<b>KX-DT343</b>	<b>KX-DT346</b>
<b>Features</b>		
<b>Display</b>	3-Line	6-Line
<b>Flexible Buttons</b>	24	24
<b>LCD Backlight</b>	✓	✓
<b>Options</b>		
<b>KX-NT303 Add-on 12 Key Module</b>	✓	✓
<b>KX-NT307 (PSLP1528) Bluetooth<sup>®</sup> Module</b> <sup>*1 *2 *3</sup>	✓	✓
<b>KX-DT301 USB Module</b> <sup>*3</sup>	✓	✓
<b>KX-DT390 DSS Console (with 60 keys)</b> <sup>*2</sup>	✓	✓

✓: Available

\*1 The availability of the Bluetooth Module depends on the software version of the connected PBX. Consult your dealer for more details.

\*2 For information on connecting, refer to the each included manual.







\*3 When connecting DPTs via Digital XDP, this optional device cannot be used.

### **Trademark:**























The Bluetooth<sup>®</sup> word mark and logos are owned by the Bluetooth SIG, Inc. and any use of such marks by Panasonic Corporation is under licence.

# Features List

## Icon Meanings

 = Flexible button   
  = Off-hook   
  = On-hook  
 = Feature number   
  = Talk   
 C.  = Confirmation Tone

## Making Calls

Calling	
<b>To an extension</b>  ► <b>extension no.</b> ► 	<b>To an outside party</b>  ►  ► <b>outside phone no.</b> ► 
Redial	
 ► REDIAL ►  ► 	
Quick Dialing	
 ► <b>quick dialing no.</b> ► 	
One-touch Dialing	
<b>To store</b> PAUSE  ►  ► ② ► <b>desired no.* (max. 32 digits)</b> ► AUTO DIAL  STORE ► PAUSE  <small>* Enter outside line access number before outside phone number.</small>	
<b>To dial</b>  ► <i>(One-touch Dialing)</i>  assigned as a One-touch Dialing button ► 	
Personal Speed Dialing	
<b>To store</b>  ► * 3 0 ► <b>personal speed dialing no. (2 digits)</b> ► <b>desired phone no.* (max. 32 digits)</b> ► #  C. Tone  <small>* Enter outside line access number before outside phone number.</small>	
<b>To dial</b>  ► AUTO DIAL  STORE ► * ► <b>personal speed dialing no. (2 digits)</b> ► 	

# Features List

## System Speed Dialling

### To dial



## Doorphone Call



## During a Conversation

### Call Hold

#### To hold



#### To retrieve a call at the holding extension



#### To retrieve an outside call from another extension



### Call Transfer

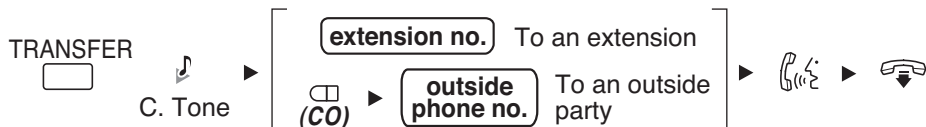

## Useful Features

### Multiple Party Conversation

#### To add other parties during a conversation (i.e., conference)



#### To leave a conference



# Using the Display Proprietary Telephone



## ◆◆ Using the Call Log or Directories

You can make a call with the call log or directories as follows:

- Outgoing Call Log
- Incoming Call Log
- Extension Number Directory
- System Speed Dialling Directory
- Personal Speed Dialling Directory

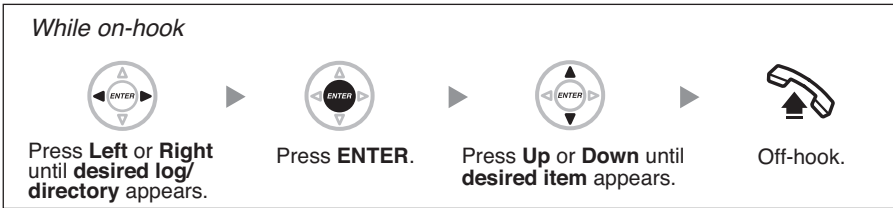
### ◆ Calling with a call log or directory



- To cancel or exit, press **CANCEL**  or **EXIT** .

### ◆ Clearing the log information

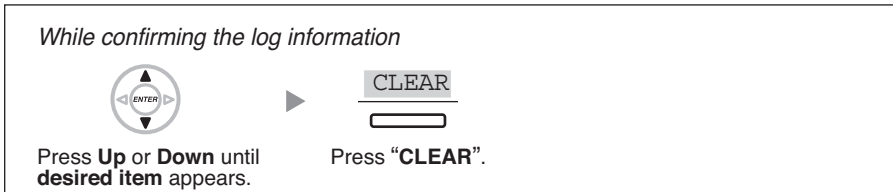

### ◆ Storing the caller's information for the Personal Speed Dialling Directory

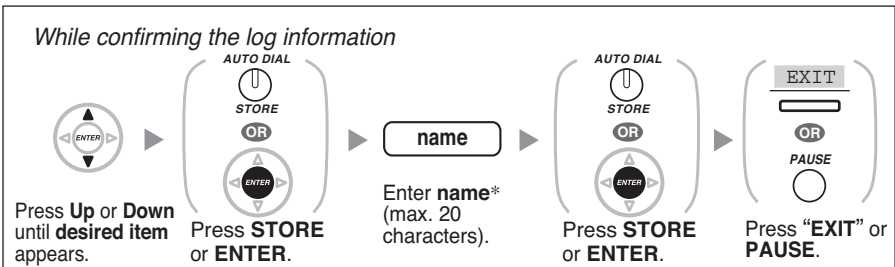

- \* To enter characters, refer to "Entering Characters".

# Using the Display Proprietary Telephone

## ◆ Storing names and numbers for the Personal Speed Dialing Directory

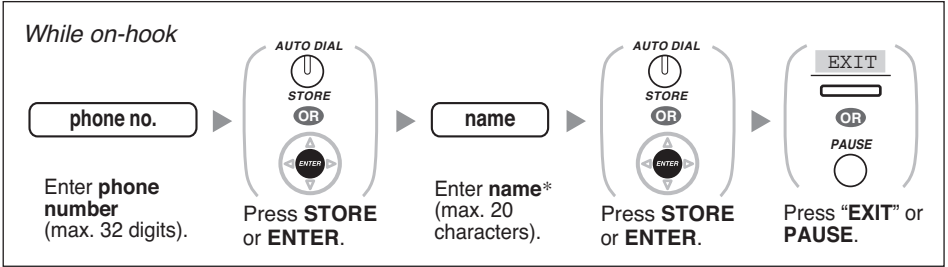

- \* To enter characters, refer to "Entering Characters".

## ◆◆ Accessing the System Features

You can access these features with the "Feature Access" menu:

- Automatic Callback**
- Group Call Pickup**
- Directed Call Pickup**
- Doorphone Call**
- Door Open**
- External Background Music**
- Paging**



- For further information, refer to the Business Telephone System User Manual.



# Accessing Features Using the Display

**Table 1 (Standard mode)**

Times Buttons	1	2	3	4	5	6	7	8	9
<b>1</b>	!	?	"	1					
<b>2</b>	A	B	C	a	b	c	2		
<b>3</b>	D	E	F	d	e	f	3		
<b>4</b>	G	H	I	g	h	i	4		
<b>5</b>	J	K	L	j	k	l	5		
<b>6</b>	M	N	O	m	n	o	6		
<b>7</b>	P	Q	R	S	p	q	r	s	7
<b>8</b>	T	U	V	t	u	v	8		
<b>9</b>	W	X	Y	Z	w	x	y	z	9
<b>0</b>	(space)	.	,	'	:	;	0		
<b>*</b>	/	+	-	=	<	>	*		
<b>#</b>	\$	%	&	@	(	)	€	£	#

**Table 2 (Option mode)**

Times Buttons	1	2	3	4	5	6	7	8	9	10	11	12	13	14	15
<b>1</b>	!	?	"	ä	ö	ü	1								
<b>2</b>	A	B	C	a	b	c	À	Á	Â	Ã	Ä	Å	Æ	Ç	2
<b>3</b>	D	E	F	d	e	f	Ð	È	É	Ê	Ë	3			
<b>4</b>	G	H	I	g	h	i	Ï	Í	Î	Ï	4				
<b>5</b>	J	K	L	j	k	l	5								
<b>6</b>	M	N	O	m	n	o	Ñ	Ò	Ó	Ô	Õ	Ö	Ø	Œ	6
<b>7</b>	P	Q	R	S	p	q	r	s	ß	7					
<b>8</b>	T	U	V	t	u	v	Û	Ú	Û	Ü	8				
<b>9</b>	W	X	Y	Z	w	x	y	z	Ý	9					
<b>0</b>	(space)	.	,	'	:	;	0								
<b>*</b>	/	+	-	=	<	>	*								
<b>#</b>	\$	%	&	@	(	)	€	£	#						

# Settings on the Programming Mode

## ◆◆ Setting Features

You can customize many features of your telephone as shown in the following tables. Original settings are shown in the grey boxes. For later reference, place a check mark in the boxes below to indicate your customized settings.

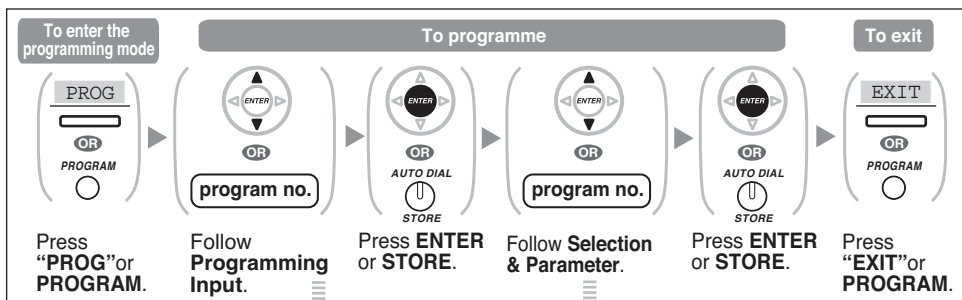

Item	Programming Input	Selection & Parameter	
Would you like to turn on the display backlight of the KX-DT343/KX-DT346? (Display Backlight Selection)	0 4 [Backlight]	0	<input type="checkbox"/> Yes—ON in use [Automatic]
		1	<input type="checkbox"/> Yes—always ON [Always On]
		2	<input type="checkbox"/> No—always OFF [Always Off]
How do you prefer to receive an intercom call? (Alternate Receiving—Ring/Voice)	2 1 [Voice Call]	0	<input type="checkbox"/> Ringing [Tone Call]
		1	<input type="checkbox"/> Directly—The party's voice is heard without ringing. [Voice Call]
		2	<input type="checkbox"/> Ring only—Prohibiting the caller switching to the voice mode. [Voice Call Deny]
Do you prefer to receive call waiting for outside calls?	3 0 [C.Wait Extrnl]	0	<input type="checkbox"/> No (No Tone) [CW Tone Off]
		1	<input type="checkbox"/> Yes (Tone) [CW Tone On]
Which type of call waiting for intercom calls do you prefer? (Call Waiting Selection)	3 1 [C.Wait Intrnl]	0	<input type="checkbox"/> No call [CW Tone Off]
		1	<input type="checkbox"/> Tone [CW Tone On]
		2	<input type="checkbox"/> Voice announcement through the built-in speaker [OHCA (Announce)]
		3	<input type="checkbox"/> Voice announcement through the handset [Whisper OHCA]
Which type of call waiting tone do you prefer? (Call Waiting Tone Type Selection)	3 2 [C.Wait Tone]	0	<input type="checkbox"/> Tone 1 [CW Tone 1]
		1	<input type="checkbox"/> Tone 2 [CW Tone 2]

# Settings on the Programming Mode

Item	Programming Input	Selection & Parameter			
Would you like to show a message on the caller's telephone display? (Absent Message)	<div style="border: 1px solid black; padding: 2px; display: inline-block;">4</div> <div style="border: 1px solid black; padding: 2px; display: inline-block;">0</div> [Absent Msg]	<div style="border: 1px solid black; padding: 2px; display: inline-block;">0</div>	<input type="checkbox"/> <b>No-Off</b> [Absent Msg Off]		
		message no. (1-8)	<input type="checkbox"/> Yes—Shows the selected message.		
		<div style="border: 1px solid black; padding: 2px; display: inline-block;">9</div>	<input type="checkbox"/> Yes—Shows your personal message.		
Where are your incoming calls forwarded or refused? (Call Forwarding [FWD]/Do Not Disturb [DND])	<div style="border: 1px solid black; padding: 5px; display: inline-block;"> <div style="border: 1px solid black; padding: 2px; display: inline-block;">5</div> <div style="border: 1px solid black; padding: 2px; display: inline-block;">0</div>                          OR                          FWD/DND  </div> (for both calls) [Fwd/DND Both]	<div style="border: 1px solid black; padding: 2px; display: inline-block;">0</div>	<input type="checkbox"/> <b>Off</b> [Fwd/DND Off]		
		<div style="border: 1px solid black; padding: 2px; display: inline-block;">1</div>	<input type="checkbox"/> Do Not Disturb (DND) [Do Not Disturb]		
		<div style="border: 1px solid black; padding: 2px; display: inline-block;">2</div> + desired no. (max. 32 digits)	<input type="checkbox"/> All—Forward all calls [Fwd All:]		
		<div style="border: 1px solid black; padding: 2px; display: inline-block;">5</div> <div style="border: 1px solid black; padding: 2px; display: inline-block;">1</div> (for outside calls) [Fwd/DND Extnl]	<div style="border: 1px solid black; padding: 2px; display: inline-block;">3</div> + desired no. (max. 32 digits)	<input type="checkbox"/> Busy—Forwarded when your extension is busy. [Fwd Busy:]	
		<div style="border: 1px solid black; padding: 2px; display: inline-block;">5</div> <div style="border: 1px solid black; padding: 2px; display: inline-block;">2</div> (for intercom calls) [Fwd/DND Intnl]	<div style="border: 1px solid black; padding: 2px; display: inline-block;">4</div> + desired no. (max. 32 digits)	<input type="checkbox"/> No Answer—Forwarded when you do not answer. [Fwd N/A:]	
			<div style="border: 1px solid black; padding: 2px; display: inline-block;">5</div> + desired no. (max. 32 digits)	<input type="checkbox"/> Busy/No Answer—Forwarded when you do not answer or when your extension is busy. [Fwd B/NA:]	
Do you use the headset? (Headset Operation)	<div style="border: 1px solid black; padding: 2px; display: inline-block;">6</div> <div style="border: 1px solid black; padding: 2px; display: inline-block;">1</div> [Headset Mode]	<div style="border: 1px solid black; padding: 2px; display: inline-block;">0</div>	<input type="checkbox"/> <b>No-Headset off</b> [Headset Mode Off]		
		<div style="border: 1px solid black; padding: 2px; display: inline-block;">1</div>	<input type="checkbox"/> Yes—Headset on [Headset Mode On]		
Would you like to set your extension PIN or change a stored extension PIN to new one? (Extension PIN [Personal Identification Number])	<div style="border: 1px solid black; padding: 2px; display: inline-block;">9</div> <div style="border: 1px solid black; padding: 2px; display: inline-block;">0</div> [Extension PIN]	extension PIN (max. 10 digits) + ENTER/STORE + same PIN	To set an extension PIN	<b>WARNING</b> When a third party discovers the password (extension PIN) of the Business Telephone System, there will be a risk that they will make fraudulent phone calls using the telephone line, and the cost will be charged to your own account. In order to avoid this problem, we strongly recommend the following points: a) Carefully maintain the secrecy of the PIN. b) Specify a complicated PIN as long and random as you can make it. c) Change the PIN frequently.	
		stored extension PIN + new PIN (max. 10 digits) + ENTER/STORE + same PIN	To change a stored extension PIN to new one		
Would you like to prevent others from seeing your personal directory and call log? (Directory and Call Log Lock)	<div style="border: 1px solid black; padding: 2px; display: inline-block;">9</div> <div style="border: 1px solid black; padding: 2px; display: inline-block;">2</div> [Display Lock]	extension PIN (max. 10 digits) + <div style="border: 1px solid black; padding: 2px; display: inline-block;">0</div>	<input type="checkbox"/> <b>To unlock</b> [Display Lock Off]		
		extension PIN (max. 10 digits) + <div style="border: 1px solid black; padding: 2px; display: inline-block;">1</div>	<input type="checkbox"/> <b>To lock</b> [Display Lock On]		



- If nothing is entered for one minute in the programming mode, the telephone returns to normal status.
- To exit the mode at any time, lift the handset.
- For further information on “Settings on the Programming Mode”, refer to the Business Telephone System User Manual.

# Location of Controls

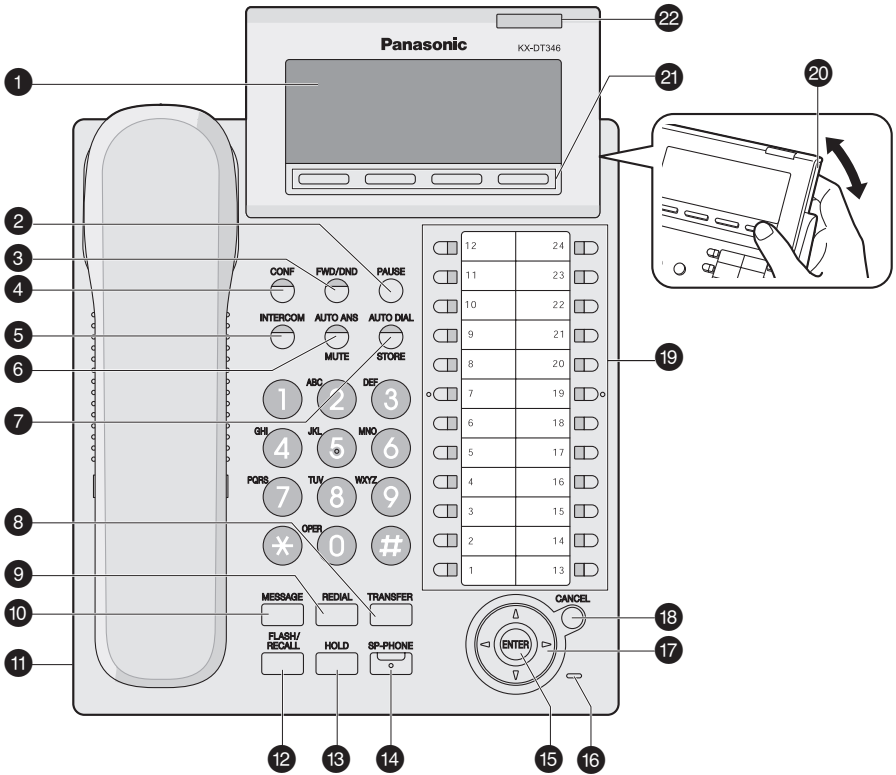

<KX-DT346>











- 1 LCD (Liquid Crystal Display)**
- 2 PAUSE:** Used to insert a pause when storing a telephone number. This button is also used for programming this unit.
- 3 FWD/DND (Call Forwarding/Do Not Disturb):** Used to set Call Forwarding or Do Not Disturb on your extension.
- 4 CONF (Conference):** Used to establish a multiple party conversation.
- 5 INTERCOM:** Used to make or receive intercom calls.
- 6 AUTO ANS (Auto Answer)/MUTE:** Used to receive an incoming call in hands-free mode or mute the microphone/handset during a conversation.
- 7 AUTO DIAL/STORE:** Used for System/Personal Speed Dialing or storing programme changes.

## *Location of Controls*

---

- 8 **TRANSFER:** Used to transfer a call to another party.
- 9 **REDIAL:** Used to redial the last dialed number.
- 10 **MESSAGE:** Used to leave a message waiting indication or call back the party who left the message waiting indication.
- 11 **Headset Jack**
- 12 **FLASH/RECALL:** Used to disconnect the current call and make another call without hanging up.
- 13 **HOLD:** Used to place a call on hold.
- 14 **SP-PHONE (Speakerphone):** Used for performing hands-free operations.
- 15 **ENTER:** Used to assign the selected item.
- 16 **Microphone:** Used for hands-free conversations.
- 17 **Navigator Key:** Used to adjust the volume and the display contrast or select desired items.
- 18 **CANCEL:** Used to cancel the selected item.
- 19 **Flexible Buttons:** Used to seize an outside line or perform a feature that has been assigned to the key.
- 20 **LCD Panel:** Can be adjusted to the desired angle.
- 21 **Soft Buttons (S1-S4):** S1-S4 (located from left to right) are used to select the item displayed on the bottom line of the display.
- 22 **Message/Ringer Lamp:** When you receive an intercom call, the lamp flashes green, and for an outside call, the lamp flashes red. When someone has left you a message, the lamp stays red.

# Settings

<b>Speaker volume</b>	<i>While in a hands-free conversation</i>	 <p>Press <b>Up</b> to increase or <b>Down</b> to decrease the volume.</p>
<b>Handset/Headset volume*<sup>1</sup></b>	<i>While using the handset or headset</i>	
<b>Ringer volume</b>	<i>While on-hook or receiving a call</i>	
<b>LCD Contrast</b>	<i>While on-hook</i>	
	PAUSE  ► 0 1 ►  ►  ►  ► PAUSE 	
<b>Ring Tone</b>	PAUSE  ► $\left( \begin{array}{c} \text{CO} \\ \text{OR} \\ \text{INTERCOM} \end{array} \right)$ ► $\left( \begin{array}{cc} 0 & 1 \\ 3 & 0 \end{array} \right)$ ► $\left( \begin{array}{c} \text{Directional pad icon} \\ \text{OR} \\ \text{AUTO DIAL} \\ \text{STORE} \end{array} \right)$ ► PAUSE  <p>Press <b>2 times.</b></p>	
<b>LCD Backlight</b>	<i>While on-hook</i>	
	PAUSE  ► 0 4 ► $\left( \begin{array}{c} \text{Directional pad icon} \\ \text{OR} \\ \text{AUTO DIAL} \\ \text{STORE} \end{array} \right)$ ► $\left( \begin{array}{l} 0 \text{ Automatic} \\ 1 \text{ Always ON} \\ 2 \text{ Always OFF} \end{array} \right)$ ► $\left( \begin{array}{c} \text{Directional pad icon} \\ \text{OR} \\ \text{AUTO DIAL} \\ \text{STORE} \end{array} \right)$ ► PAUSE 	

\*<sup>1</sup> If you hear your own voice through the handset or headset, decrease the volume.

<Back view>

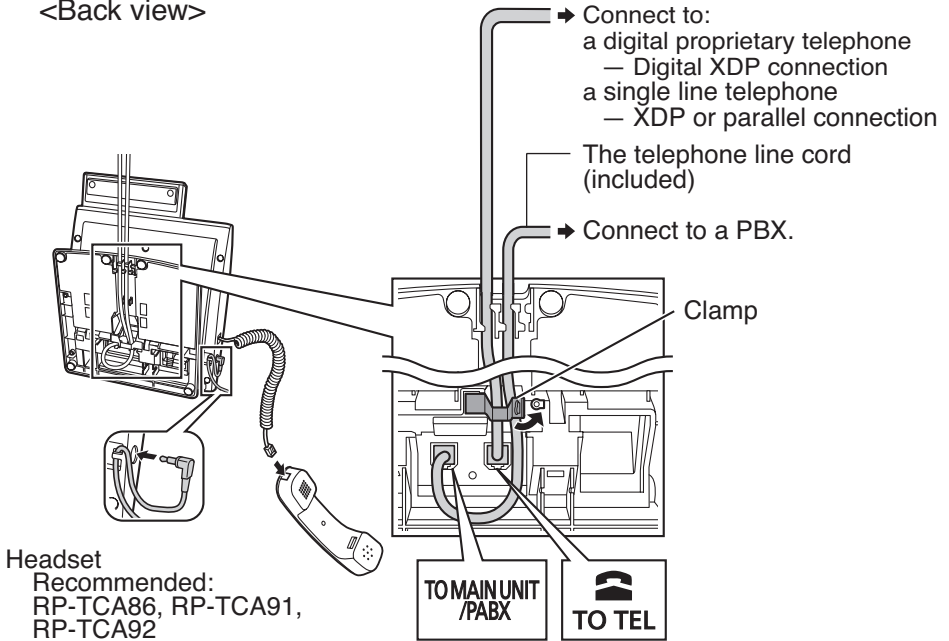

- Consult your dealer for more details about XDP and Digital XDP.

## CAUTION:

### When connecting a headset

- Ensure that the headset cord is wound around the hook to prevent damage to the connector.

### When connecting cords

- Ensure the cords are inserted in the grooves, and are clamped to prevent damage to the connectors.

# Wall Mounting

1. Remove the wall mounting adaptor from the unit as shown.
2. Set the operation board to level 1, then connect and secure the telephone line cords.
  - The cords can also be run from the top of the unit.

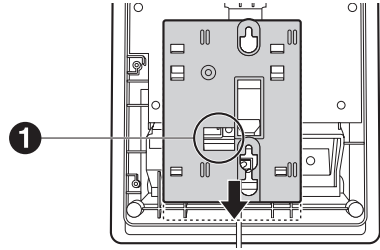

3. Attach the wall mounting adaptor as shown.
  - Make sure the cords are not pinched by the wall mounting adaptor. When running the cords from the top of the unit, look through the opening in the wall mounting adaptor (1) to confirm that the cords are not being pinched.

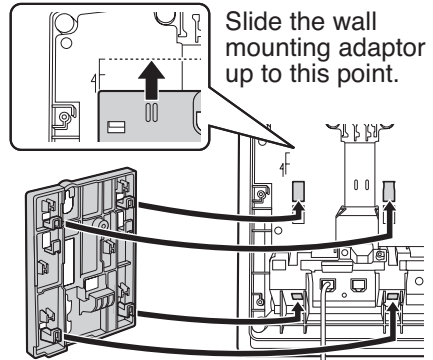

4. Drive the 2 screws (included) into the wall either 83 mm or 100 mm apart, and mount the unit on the wall.
  - Make sure that the wall that the unit will be attached to is strong enough to support the unit (approx. 1.65 kg [3.64 lb]).
  - Make sure the cords are securely fastened to the wall.
  - When this unit is no longer in use, make sure to detach it from the wall.

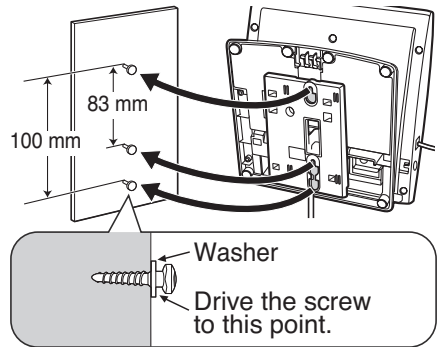



# Installing KX-DT301/KX-NT303

## CAUTION:

- To prevent damage to the telephone, be sure to unplug the extension line before you set up or remove the KX-DT301 (USB Module) or the KX-NT303 (Add-on 12 Key Module).
- Connect the KX-NT303 first when installing both the KX-DT301 and the KX-NT303.

## KX-NT303

The Add-on 12 Key Module allows 12 additional flexible buttons to be added to this unit. These buttons are used to seize an outside line, make a call using One-touch Dialling, or perform a feature that has been assigned to the key.



<with a KX-DT346>

1. Open the cover.

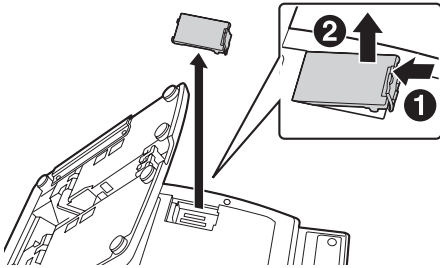

2. Attach the KX-NT303 to your unit with the screws (included with KX-NT303).

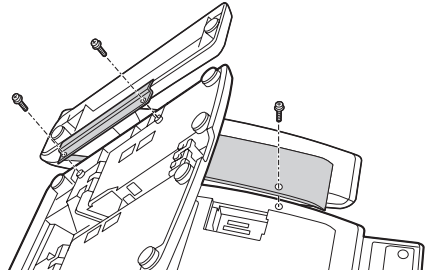

3. Plug the flat cable into the connector (1), then bend the cable slightly as shown (2).

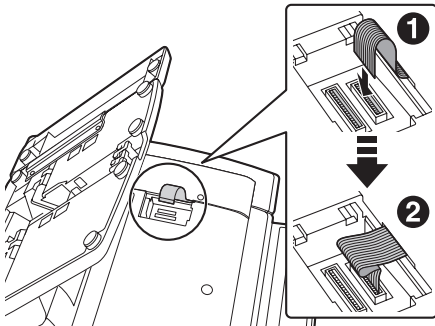

4. Close the cover.

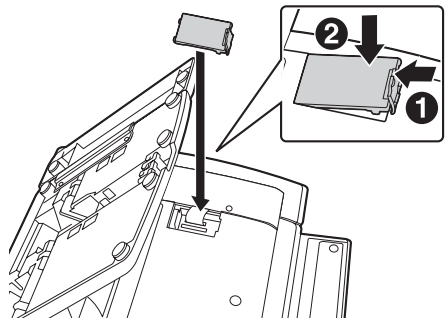

# Installing KX-DT301/KX-NT303

## KX-DT301

The USB Module can be connected between the DPT and the personal computer through USB interface to implement personal CTI (Computer Telephony Integration).

1. Open the cover.

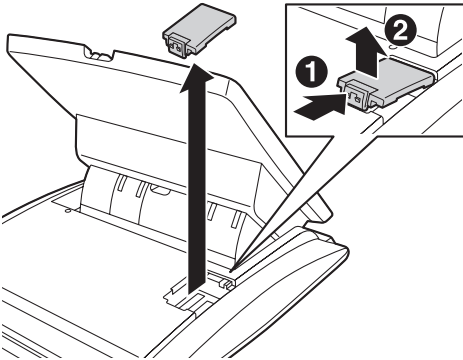

2. Plug the flat cable into the connector as shown.

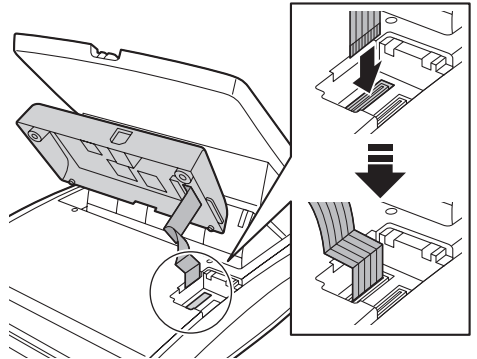

3. Close the cover.

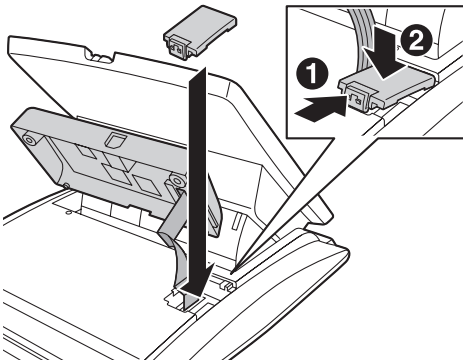

4. Connect the USB cable to the USB port.

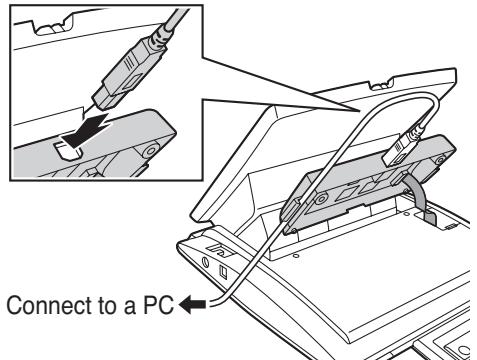

- Ensure that the USB cable goes through the cable guide.
- Please use a USB cable shorter than 3 m.

## ***Installing KX-DT301/KX-NT303***

- 5.** Insert the protrusions on the KX-DT301 into the 2 holes in the unit.

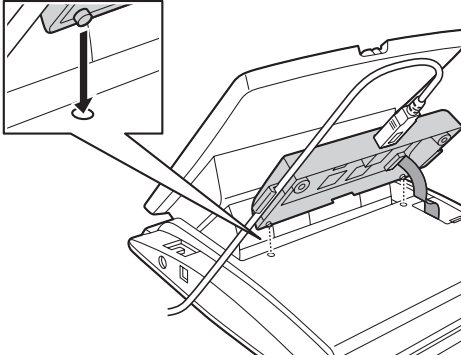

- 6.** Attach the KX-DT301 to your unit with the screws (included with KX-DT301).

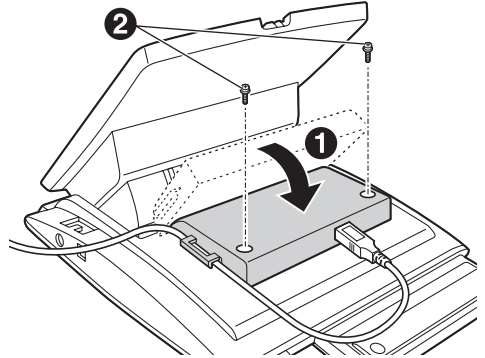

- 7.** Install the USB driver. Refer to Installation Manual on the CD-ROM included with KX-DT301.

**Panasonic Canada Inc.**

5770 Ambler Drive, Mississauga, ON L4W 2T3  
[www.panasonic.ca](http://www.panasonic.ca)

**PSQX46842A** KK1208YHO©