

NEC

DS2000

Hardware Manual

80000INS07
April 2001 (2106)

Printed in U.S.A.

1. Installing the
Cabinet

2. PCB Installation

3. Installing
Extensions and Trunks

4. Optional
Equipment

5. Maintenance
Options and SMDR

6. Specifications
and Parts

This manual has been developed by NEC America, Inc. It is intended for the use of its customers and service personnel, and should be read in its entirety before attempting to install or program the system. Any comments or suggestions for improving this manual would be appreciated. Forward your remarks to:

NEC America, Inc., Corporate Networks Group

4 Forest Parkway
Shelton, CT 06484
cng.nec.com

Nothing contained in this manual shall be deemed to be, and this manual does not constitute, a warranty of, or representation with respect to, any of the equipment covered. This manual is subject to change without notice and NEC America, Inc. has no obligation to provide any updates or corrections to this manual. Further, NEC America, Inc. also reserves the right, without prior notice, to make changes in equipment design or components as it deems appropriate. No representation is made that this manual is complete or accurate in all respects and NEC America, Inc. shall not be liable for any errors or omissions. In no event shall NEC America, Inc. be liable for any incidental or consequential damages in connection with the use of this manual. This document contains proprietary information that is protected by copyright. All rights are reserved. No part of this document may be photocopied or reproduced without prior written consent of NEC America, Inc.

©2001 by NEC America, Inc.. All Rights Reserved.
Printed in U.S.A.

Section 1, INSTALLING THE CABINET

In this section . . .	Page
Installing the Cabinet	1-3
Unpacking	1-3
Before Installing	1-3
Site Requirements	1-3
Planning the Installation for a 4 Slot Main Equipment Cabinet	1-4
Planning the Installation for an 8 Slot Main Equipment Cabinet	1-5
Removing the Cover	1-7
Unpacking the Wall Mount Bracket	1-8
Mounting the Wall Mount Bracket	1-8
Hanging the Cabinet	1-9
Grounding the Cabinet	1-11
Removing the Right Side Panel	1-11
Attaching the Ground Wires	1-13

In this section . . .	Page
RFI Suppressor Assemblies	1-14
Installing the RFI Suppressor Assemblies	1-14
Power Supply Installation	1-16
Installing the Power Supply	1-16
System Configuration - U Slot	1-17
U Slot Configuration Guidelines	1-17
System Load Factor Calculations	1-18
U Slot Default Settings	1-19
System Configuration - Fixed Slot	1-20
Fixed Slot Configuration Guidelines	1-20
Fixed Slot Default Settings	1-20

— For Your Notes —

INSTALLING THE CABINET

Unpacking

Unpack the equipment and check it against your equipment lists. Inspect for physical damage. If you are not sure about a component's function, review the Product Description Manual. Contact your Sales Representative if you have additional questions.

Have the appropriate tools for the job on hand, including: a test set, a punch down tool and a digital voltmeter.

Before Installing

Make sure you have a building plan showing the location of the common equipment, extensions, the telco demarcation and earth ground. In addition, the installation site must meet the requirements outlined in the Standard Practices Manual.

Site Requirements

The common equipment is contained in the wall-mounted Main Equipment Cabinet. Choose a central location for the cabinet that allows enough space for the equipment — and provides enough room for you to comfortably work. The Installation Layout (Figures 1-1 and 1-2) shows you *about* how much space your system requires.

INSTALLING THE CABINET

Planning the Installation for a 4 Slot Main Equipment Cabinet (Figure 1-1)

Before installing the common equipment, you should mount a Main Distribution Frame (MDF) plywood backboard in a centrally located spot. A 1/2 sheet of plywood (4' x 4') should be more than adequate. Mount this backboard using suitable fasteners, taking care to adhere to standard installation practices and local codes.

The equipment cabinet requires a three-prong, dedicated 110 VAC 60 Hz circuit (NEMA 5-15 receptacle) located within 7 feet of the AC receptacle.

Normally, you install the extension and trunk blocks to the right of the Main Cabinet. Telco should also install the RJ21X to the right of the Main Cabinet.

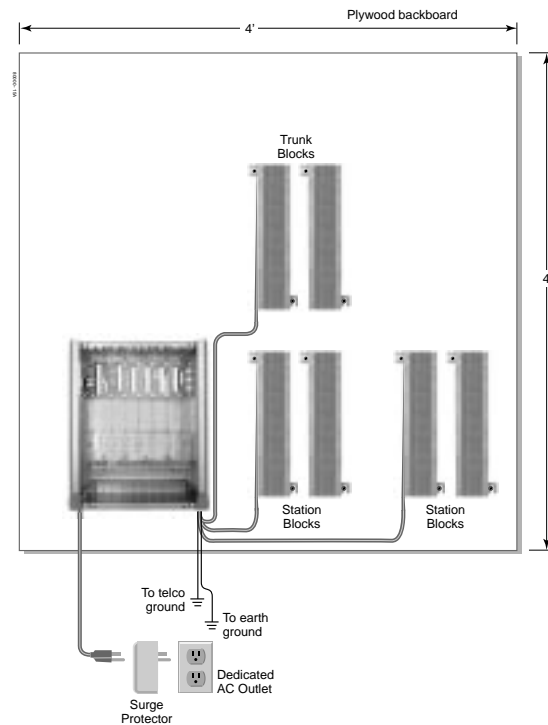

Figure 1-1 4 SLOT INSTALLATION LAYOUT

INSTALLING THE CABINET

Planning the Installation for an 8 Slot Main Equipment Cabinet (Figure 1-2)

Before installing the common equipment, you should mount a Main Distribution Frame (MDF) plywood backboard in a centrally located spot. A full sheet of plywood (8' x 4') should be more than adequate. Mount this backboard using suitable fasteners, taking care to adhere to standard installation practices and local codes.

The equipment cabinet requires a three-prong, dedicated 110 VAC 60 Hz circuit (NEMA 5-15 receptacle) located within 7 feet of the AC receptacle.

Normally, you install the extension and trunk blocks to the right of the Main Cabinet. Telco should also install the RJ21X to the right of the Main Cabinet.

INSTALLING THE CABINET

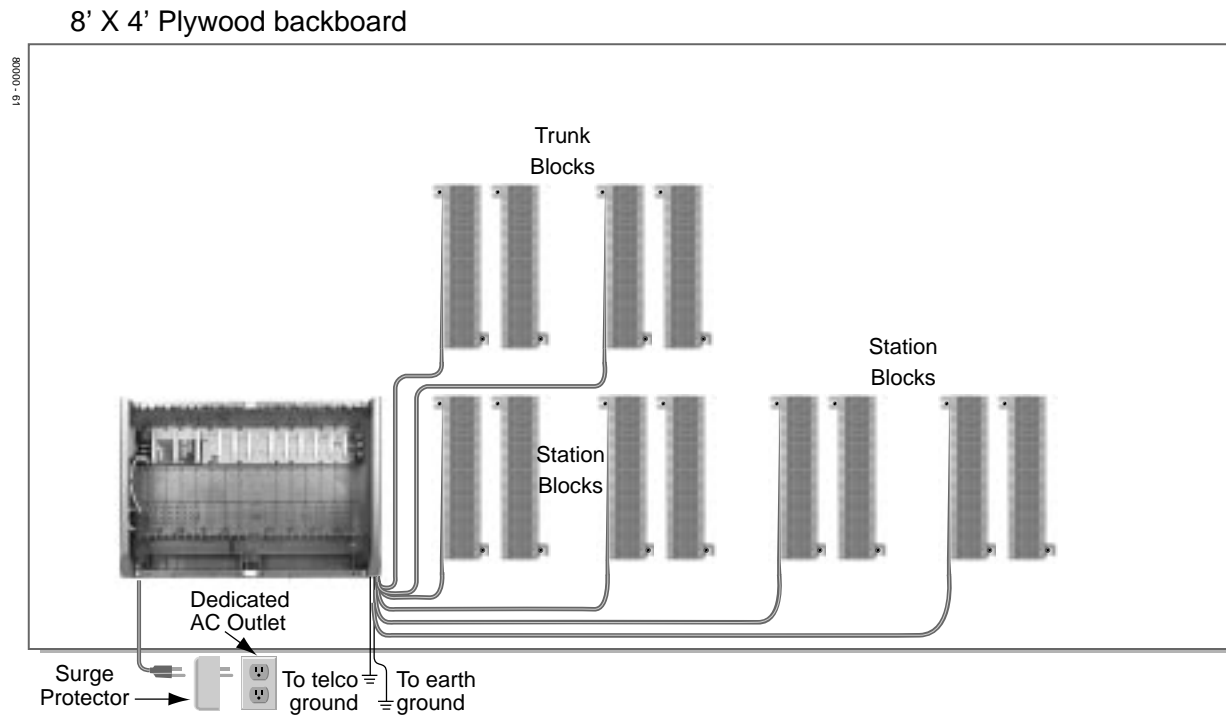

Figure 1-2 8 SLOT INSTALLATION LAYOUT

INSTALLING THE CABINET

Removing the Cover (Figure 1-3)

Before wall-mounting, remove the cover on the Main Equipment Cabinet.

1. Unscrew the two captive screws on the front of the cabinet cover.
2. Lift up slightly on the front of the cover — then gently slide the cover back to remove it.

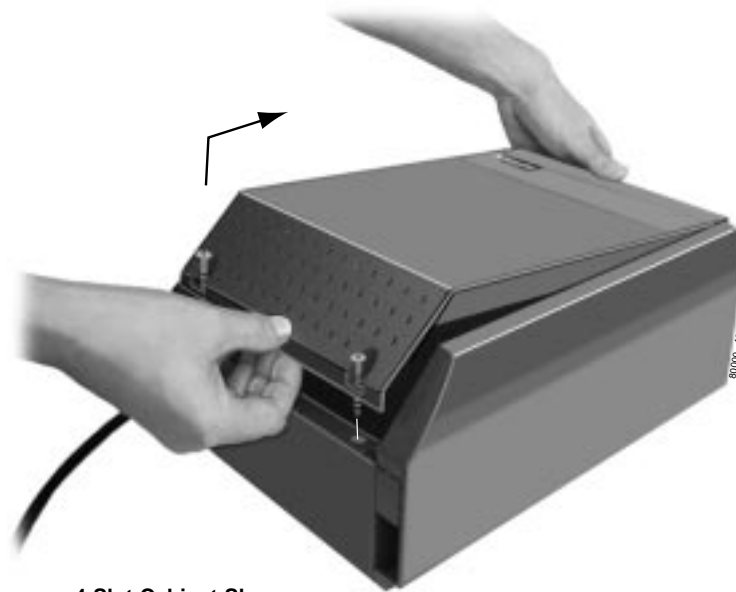

4 Slot Cabinet Shown

Figure 1-3 REMOVING THE COVER

INSTALLING THE CABINET

Unpacking the Wall Mount Bracket (Figure 1-4)

The wall mount bracket and screws are taped to the packing material in the Main Equipment Cabinet box. Unpack the wall mount bracket and mounting screws.



Figure 1-4 WALL MOUNT BRACKET

Mounting the Wall Mount Bracket (Figure 1-5)

Mount the wall mount bracket on the MDF in a convenient location, about 12" higher than where you want the bottom of the cabinet to line up.



Figure 1-5 MOUNTING THE WALL MOUNT BRACKET

INSTALLING THE CABINET

Hanging the Cabinet (Figures 1-6 and 1-7)

1. Hang the Main Equipment Cabinet on the wall mount hanger as shown:
 - See Figure 1-6 when hanging a 4 slot cabinet.
 - See Figure 1-7 when hanging an 8 slot cabinet.
2. Using the remaining screws that were packed with the hanger, secure the cabinet to the plywood backboard.

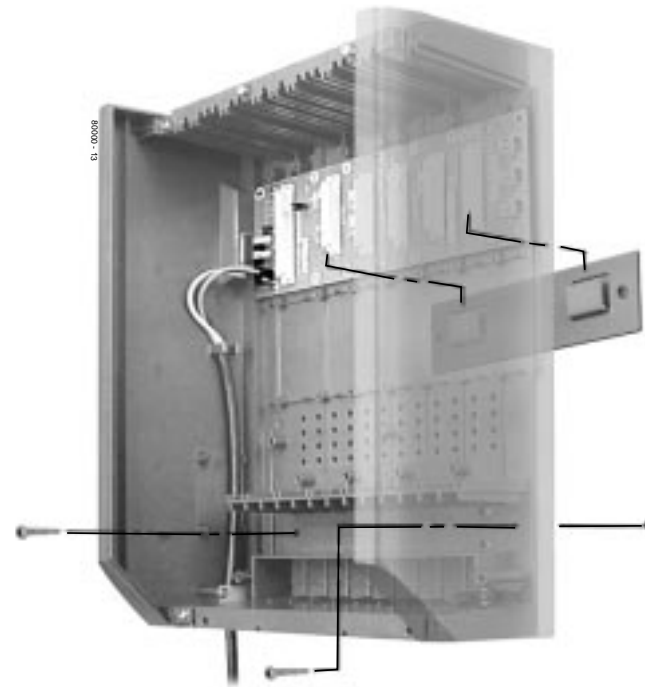

Figure 1-6 HANGING THE 4 SLOT CABINET

1-9

1. Installing the
Cabinet

INSTALLING THE CABINET

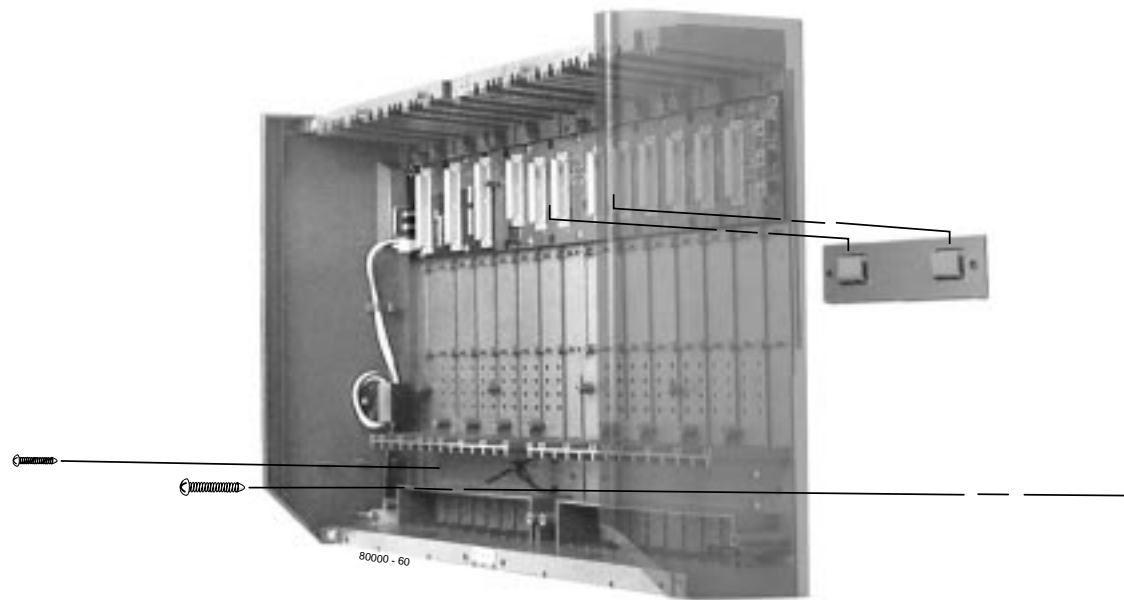

Figure 1-7 HANGING THE 8 SLOT CABINET

GROUNDING THE CABINET

Removing the Right Side Panel (Figure 1-8)

Remove the cabinet right side panel to gain easy access to the ground lugs and system cabling. The cabinet has two ground connections: ETH (Earth Ground) and PBXG (PBX Ground).

1. Remove the two screws that secure the right side panel to the cabinet.
2. Carefully slide the right side panel down until it swings clear of the cabinet.

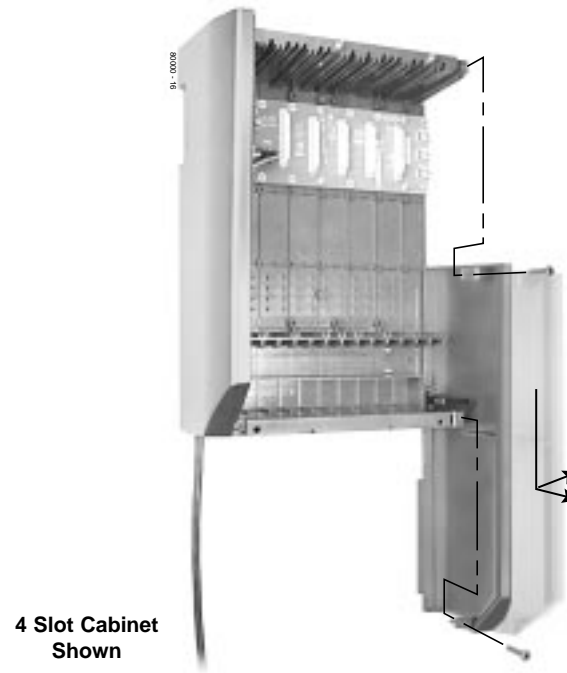

Figure 1-8 REMOVING THE SIDE PANELS

1-11

1. Installing the
Cabinet

GROUNDING THE CABINET

— For Your Notes —

GROUNDING THE CABINET

Attaching the Ground Wires (Figure 1-9)

The system provides two ground terminations. Each ground connects from the system to the ground termination using 12 AWG stranded copper wire (see Figure 1-9).

- Use the ETH (Earth Ground) for safety/system ground. You **must** connect ETH to a known earth ground.
- Use the PBXG (PBX Ground) if you have trunks that require telco ground (such as ground start trunks). This ground is not required for loop start trunks.

1. Remove the lug on the ground connection you want to connect.
2. Follow Figure 1-10 and run the ground wire(s) through the RFI Suppressor Assembly as shown.
3. For Earth Ground:
Run a ground wire from the ETH lug to a known earth ground.
For PBX Ground:
Run a ground wire from the PBXG lug to the telco ground.
4. Crimp ring terminals as required to the ground wires.
5. Reinstall and firmly tighten the lug(s) removed in step 1 above.

Do not plug in the power cord or reinstall the right side panel until all PCB installation and cabling are complete.

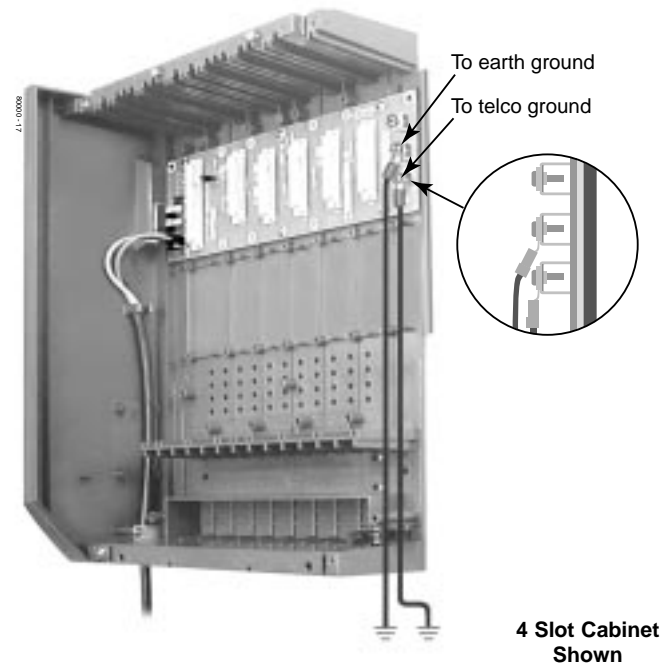

Figure 1-9 ATTACHING THE GROUND WIRES

w!!

he
RS-
f-
onal
able.
s

g.,
nly
0021.

RFI SUPPRESSOR ASSEMBLIES

Installing RFI Suppressor Assemblies (Figure 1-10)

You must install RFI Suppressor Assemblies as follows. The suppressors *must* be mounted inside the cabinet and as close to the appropriate PCB as possible.

- **For Station and Trunk Cables**

- Only install these assemblies if you are installing **non-A** station and trunk PCBs in a 4 slot cabinet. If you have a mixture of A and non-A PCBs, you only need to install the assemblies on the non-A PCBs.
- RFI assemblies on station and trunk cables are not required with 8 slot cabinets, since these cabinets use only **A** PCBs.

- **For Ground Wires**

- You must install a separate RFI assembly for the ground wire(s) in all systems.
- If your system has 2 ground wires, install them both in the same assembly.

- **For CPU Connections**

- You must install a separate RFI assembly for the CPU mod jack and RS-232 cables in all systems. Install both cables in the same assembly.

RFI SUPPRESSOR ASSEMBLIES

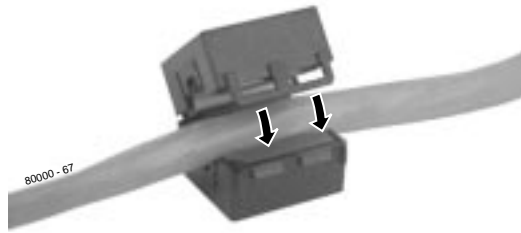

For Station and Trunk Cables

- Required only when using non-A station and trunk PCBs in 4 slot cabinets:
 - 16DSTU PCB P/N 80021
 - 8ASTU PCB P/N 80041
 - 4ASTU PCB P/N 80040
 - 4ATRU PCB P/N 80010
 - 8ATRU PCB P/N 80011
- Not required for 8 slot cabinets. All 8 slot cabinets must use A station and trunk PCBs.

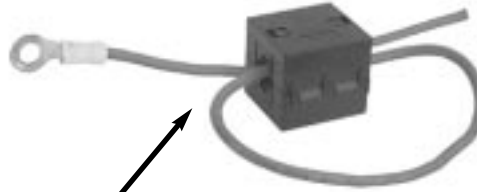

For Ground Wire(s)

- Required for all installations.



For CPU Connections

- Required on CPU mod jack and RS-232 cables for all installations.

Figure 1-10 INSTALLING RFI SUPPRESSOR ASSEMBLIES

POWER SUPPLY INSTALLATION

Installing the Power Supply (Figures 1-11 and 1-12)

The power supply provides the DC power sources required to operate the system:

1. Slide the power supply into the CN101 slot as shown at right.
2. Using a long-shaft phillips head screwdriver, tighten the two screws that secure the power supply.

An 8 slot cabinet may require up to 3 power supplies, using slots CN101, CN102 and CN103. Refer to System Configuration on page 1-17 for more.



Figure 1-11 POWER SUPPLY

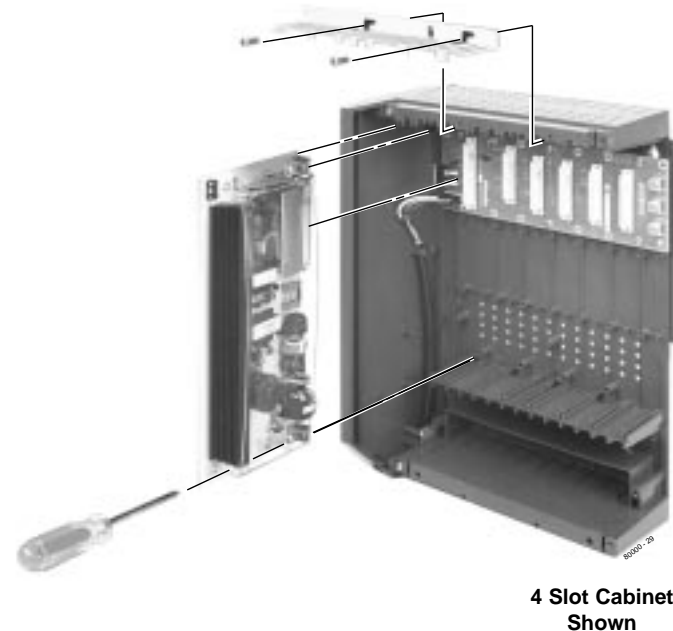

Figure 1-12 Installing the Power Supply

SYSTEM CONFIGURATION - U SLOT

U Slot Configuration Guidelines

U Slot systems use software version 02.**.** or higher.

The total number of components you can install and connect depends on power supply capacity and the System Load Factor. Review the Configuration Guidelines at right and *System Load Factor Calculations* on page 1-18 when configuring your system. Also read *U Slot Default Settings* on page 1-19. You may find that the default setup is adequate for your needs.

Also see *Where to Install the PCBs in your U Slot System* on page 2-2.

Notes for U Slot Software

- *U Slot (02.nn.nn) software is available with both 4 and 8 slot cabinets.*

4 Slot Cabinets

- Do not install more than 2 16DSTU PCBs installed under any circumstances.
- The first 16DSTU PCB you install must be in the first slot.
- You can install up to **40 extensions** maximum, as follows:
 - (2) 16DSTU PCBs = 32 digital extensions
 - (1) 8ASTU PCB = 8 analog extensionsTotal = 40 extensions
- You can install up to **24 trunks** maximum, as follows:
 - (3) 8ASTU PCBs = 24 analog trunks
- Maximum configuration is **48 ports**.
- The total of all extensions and trunks cannot exceed **48**.
- Always use the System Load Factor Table to check your system configuration.

8 Slot Cabinets

- Do not install more than 2 16DSTU PCBs for each power supply.
- The first 16DSTU PCB you install must be in the first slot (CN1).
- You can install up to **96 extensions** maximum.
- You can install up to **48 trunks** maximum.
- The total of all extensions and trunks installed cannot exceed **104**.
- Maximum configuration is **104 ports**.
- 8-slot cabinet **require**. A series PCBs, as follows:
 - CPU PCB P/N 80025A
 - Power Supply P/N 80005A
 - 16DSTU Digital Station PCB P/N 80021A
 - 8 ASTU 8 Port Analog Station PCB P/N 80041A
 - 4ASTU 4 Port Analog Station PCB P/N 80040A
 - 8ATRU 8 Port Analog Trunk PCB P/N 80011A
 - 4ATRU 4 Port Analog Trunk PCB P/N 80010A
- Always use the System Load Factor Table to check your system configuration.

1. Installing the Cabinet

SYSTEM CONFIGURATION - U SLOT

System Load Factor Calculations

To check your system configuration:

1. In the table at right, indicate the quantity for each item installed in the **Qty** column.
2. For each item, multiply the **Qty** times the Load Factor and enter the value in the **Total Load** column.
3. Add all the values in the **Total Load** column and enter the value in **Item 1**.
4. Determine the System Load Factor capacity of the power supplies installed in your system and enter the total in **Item 2**.

A 4-slot cabinet can have only 1 power supply. An 8-slot cabinet can have up to 3 power supplies. You cannot have more than two 16DSTU PCBs per power supply, regardless of System Load Factor calculations.

Exceeding the System Load Factor will cause the system's power supplies to automatically shut down.

5. Compare the entry in **Item 2** to your entry in **Item 1**. **Item 1** must always be equal to or less than the entry in **Item 2**.

Do not operate your system if the System Load Factor total (**Item 1**) exceeds the allowable value (**Item 2**).

System Load Factor Calculations			
Description	Load Factor	Qty	Total Load
16DSTU PCB	16		
4ASTU PCB	8		
8ASTU PCB	12		
110-Button DSS Console	2		
24-Button DSS Console	1		
Total DSS Consoles installed cannot exceed 4.			
2-OPX Module	3		
Item 1: Total load for this configuration:			
Item 2: If you have <u>one</u> power supply installed, enter 48. If you have <u>two</u> power supplies installed, enter 80. If you have <u>three</u> power supplies installed, enter 112. (2 16DSTU PCBs maximum per power supply)			
Note: An 8-Slot Cabinet can have up to 3 power supplies. You cannot have more than two 16DSTU PCBs per power supply, regardless of System Load Factor calculations.			

SYSTEM CONFIGURATION - U SLOT

U Slot Default Settings

If you have a U Slot system (software version 02.**.**), following are the default configurations. If you have a fixed slot system (software 01.**.**), turn to page 1-20.

- **4 Slot Cabinet with CPU P/N 80025**

Default configuration: 16 trunks x 32 extensions

Slot CN1 = 16 DSTU PCB (Extensions 300-315)

Slot CN2 = 16 DSTU PCB (Extensions 316-331)

Slot CN3 = 8 ATRU PCB (Trunks 1-8)

Slot CN4 = 8 ATRU PCB (Trunks 9-16)

- **4 Slot Cabinet with CPU P/N 80025A**

Default configuration: 0 trunks x 64 extensions

Slot CN1 = 16 DSTU PCB (Extensions 300-315)

Slot CN2 = 16 DSTU PCB (Extensions 316-331)

Slot CN3 = 16 DSTU PCB (Extensions 332-347)

Slot CN4 = 16 DSTU PCB (Extensions 348-363)

Notes on this configuration:

1. Slots CN5-CN8 are not available.
2. **You cannot install this configuration as is**; it has too many 16DSTU PCBs. You must use **9902: Slot Control** to reconfigure your PCBs. See your system's *Release Notes* or *Software Manual* for more on using **9902: Slot Control**.

- **8 Slot Cabinet with CPU P/N 80025A**

Default configuration: 24 trunks x 80 extensions

Slot CN1 = 16 DSTU PCB (Extensions 300-315)

Slot CN2 = 16 DSTU PCB (Extensions 316-331)

Slot CN3 = 16 DSTU PCB (Extensions 332-347)

Slot CN4 = 16 DSTU PCB (Extensions 348-363)

Slot CN5 = 16 DSTU PCB (Extensions 364-379)

Slot CN6 = 8 ATRU PCB (Trunks 1-8)

Slot CN7 = 8 ATRU PCB (Trunks 9-16)

Slot CN8 = 8 ATRU PCB (Trunks 17-24)

Notes on this configuration:

1. This configuration requires 3 power supplies.
2. 8 Slot cabinets **require** A version PCBs.

SYSTEM CONFIGURATION - FIXED SLOT

Fixed Slot Configuration Guidelines

Fixed Slot systems use software version 01.**.**. The maximum configuration of your fixed slot system is 16 trunks and 32 extensions. Also see *Where to Install the PCBs in your Fixed Slot System* on page 2-5.

Load factor in your fixed slot system is an issue only if you have DSS Consoles and 2-OPX Modules installed (see the *System Load Factor Calculations* chart on page 1-18).

Exceeding the load factor will cause your system's power supply to automatically shut down.

Fixed Slot Default Settings

If you have a Fixed Slot system (software version 01.**.**), following is the default configuration. If you have a U Slot system (software 02.**.**), turn to page 1-17.

- **4 Slot Cabinet with Fixed Slot Software and CPU P/N 80025**

Default configuration: 16 trunks x 32 extensions

Slot CN1 = 16 DSTU PCB (Extensions 300-315)

Slot CN2 = 16 DSTU PCB (Extensions 316-331)

Slot CN3 = 8 ATRU PCB (Trunks 1-8)

Slot CN4 = 8 ATRU PCB (Trunks 9-16)

Notes on this configuration:

1. You can plug DSTU PCBs only into slots CN1 and CN2.
1. You can only plug an ASTU PCB only into slot CN2 (in place of the second DSTU PCB).
2. Install ATRU PCBs only into slots CN3 and CN4.

Notes for Fixed Slot Software

- *Fixed slot (01.nn.nn) software is only compatible with 4 slot cabinets.*
- Fixed slot software is no longer available, but you may encounter it in existing installations.
- You can plug 16DSTU PCBs only into slots CN1 and CN2. Do not install more than 2 16DSTU PCBs under any circumstances.
- You can plug an ASTU PCB only into slot CN2 (in place of the second DSTU PCB).
- Install ATRU PCBs only into slots CN3 and CN4.
- System Load Factor in Fixed Slot systems is only an issue if you have DSS Consoles and 2-OPX Modules installed. Note that you cannot install more than 4 DSS Consoles, regardless of System Load Factor.
- The *Release Notes* that came with your system indicate if it uses Fixed Slot software.
- Check your system's *Hardware Manual* for more installation details.
- Maximum configuration for 4-slot cabinets with Fixed Slot software is **16 trunks, 32 extensions and 48 ports.**

Section 2, PCB INSTALLATION AND STARTUP

In this section . . .	Page
PCB Location - U Slot	2-2
Where to Install the PCBs in your U Slot System.	2-2
PCB Location - Fixed Slot	2-5
Where to Install the PCBs in your Fixed Slot System.	2-5
Installing PCBs	2-7
Central Processing Unit (CPU) PCB.	2-7
Installing the CPU	2-8
Digital Station (16DSTU) PCB.	2-9
Analog Station (8ASTU and 4ASTU) PCBs.	2-10

In this section . . .	Page
Installing PCBs (cont'd)	
Analog Trunk (8ATRU and 4ATRU) PCB	2-11
8 Circuit Caller ID Daughter Board	2-12
4 Circuit Caller ID Daughter Board	2-14
Connecting Blocks	2-16
Working with 8-Pin Jacks	2-16
Punching Down the Cables.	2-16
Making your own Cables	2-16

!! Important !!
Install telephones connected to DSTU and ASTU PCBs as on-premise extensions only.

PCB LOCATION - U SLOT

Where to Install the PCBs in your U Slot System (Figures 2-1 and 2-2)

Review *System Configuration - U Slot* on page 1-17 before installing any PCBs.

- When installing PCBs in a U Slot 4 slot system, follow Figure 2-1. You **must** install a 16DSTU in slot CN1.
- When Installing PCBs in a U Slot 8 slot system, follow Figure 2-2. You **must** install a 16DSTU in slot CN1.

Item	Description	Location	Max.
CPU	Central Processing Unit	CN0	1
16DSTU	16 Digital Stations	CN1	1
All other PCBs		CN2-CN8	7

Caution

Do not plug in the CPU PCB hot (i.e., with the system power applied).

You can plug in ASTU and ATRU PCBs hot as required.

You can plug in DSTU PCBs hot provided you first disconnect the station cabling from the PCB.

PCB LOCATION - U SLOT

Defaults shown

!! Important Note for 4 Slot Cabinets with CPU P/N 80025A !!

Your system slot assignments must be reprogrammed:

- Using 9902 - Slot Control, **delete slots 2-8** and reprogram your slot assignments as required.
Even though your system has only 4 slots, slots 2-8 exist the data base and must be reprogrammed.
- Slot 1 is permanently assigned as the system's first 16DSTU PCB and cannot be changed.

**Default U Slot
setup with CPU
P/N 80025A**

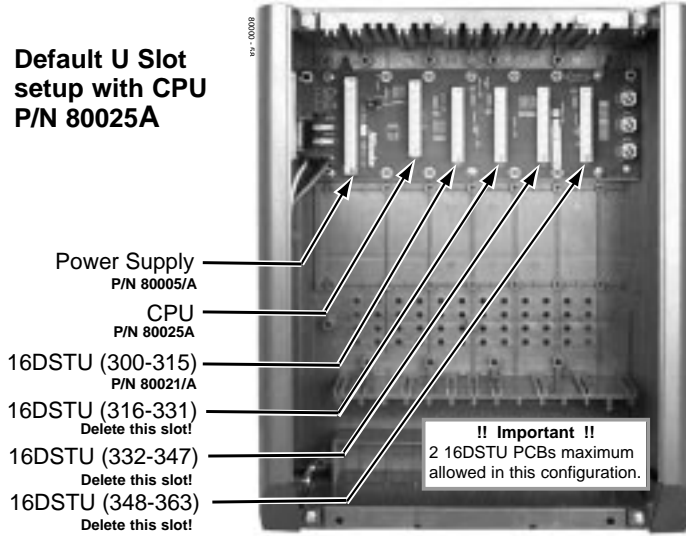

**Default U Slot
setup with CPU
P/N 80025**

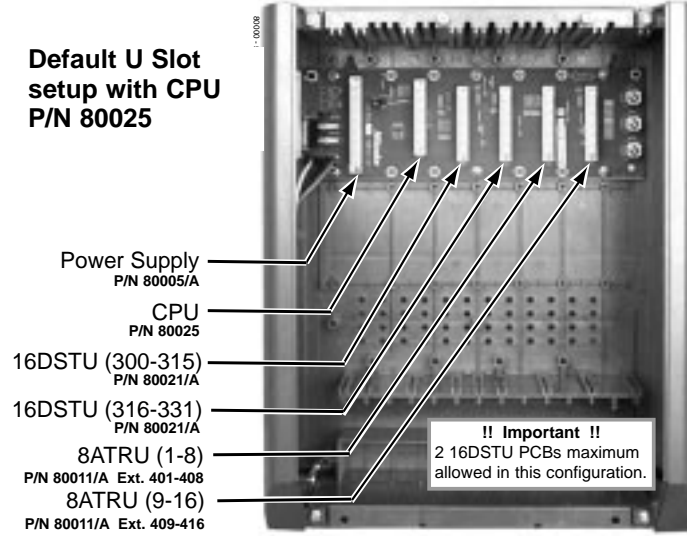

Figure 2-1 4 SLOT PCB LOCATION

PCB LOCATION - U SLOT

!! Important !!

When plugging in PCBs:

- Use the default assignments shown in the illustration below.
- OR
- Using **9902 - Slot Control**, **delete slots 2-8** and reprogram your slot assignments as required.
- Slot 1 is permanently assigned as the system's first 16DSTU PCB and cannot be changed.

Defaults shown

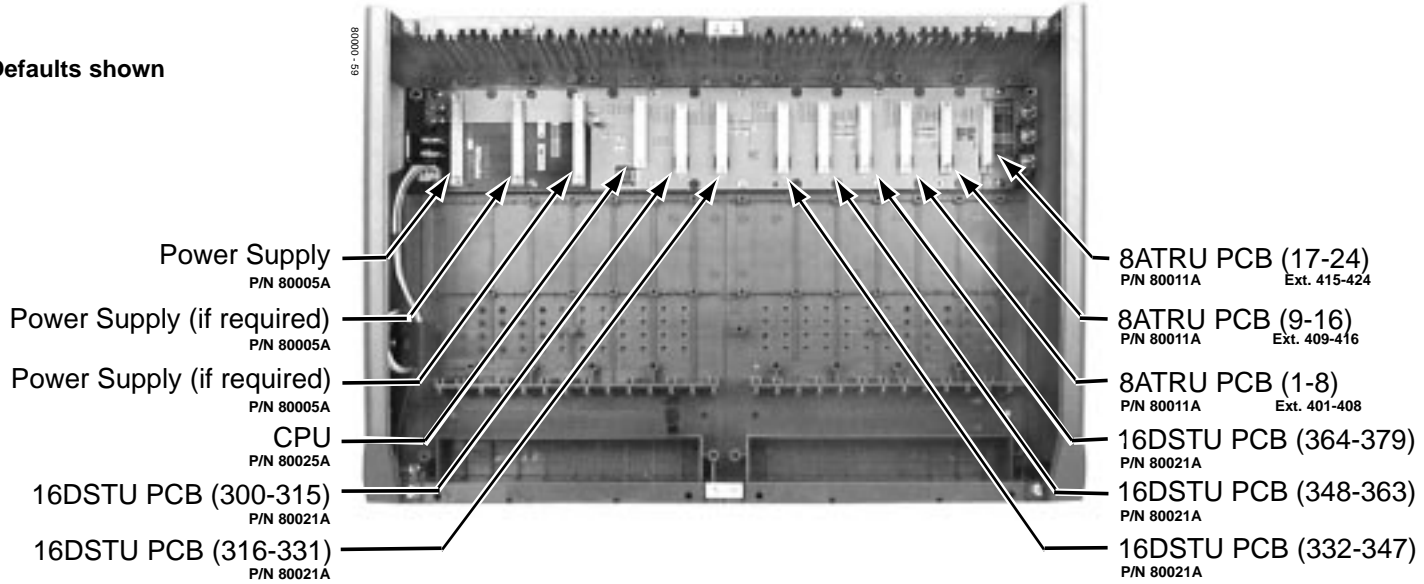

Figure 2-2 8 SLOT PCB LOCATION

PCB LOCATION - FIXED SLOT

— For Your Notes —

INSTALLING PCBs

Central Processing Unit (CPU) PCB (Figure 2-4)

The CPU provides:

- The system's central processing, stored program and memory for the customer's site-specific data.
- PC Card interface.
- Conference circuits, DTMF receivers and DTMF generators.
- External music input and on-board synthesized music source.
- External paging output and associated relay.
- Real Time Clock
- Battery for short term (14 day) backup of the customer's site-specific data.

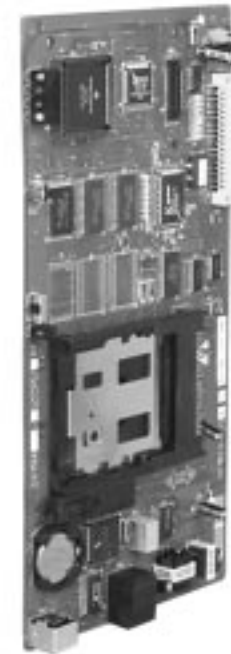

Figure 2-4 CPU PCB

INSTALLING PCBs

Installing the CPU (Figures 2-5 and 2-6)

CPU PCB installs in the CN0 slot in the Main Equipment Cabinet.

● **To install the CPU PCB:**

1. Slide the Mode Switch to the RUN position (see Figure 2-5).
2. Insert the battery into the battery clips.
3. Plug the CPU into slot CN0 (see Figure 2-6).

Refer to *Part 4, Installing Optional Equipment* for instructions on connecting the music source, External Paging and the auxiliary relay.

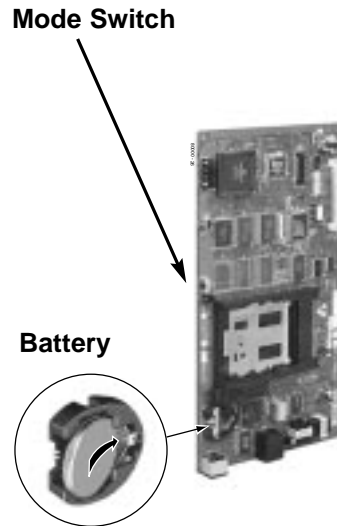

Figure 2-5 Setting up the CPU

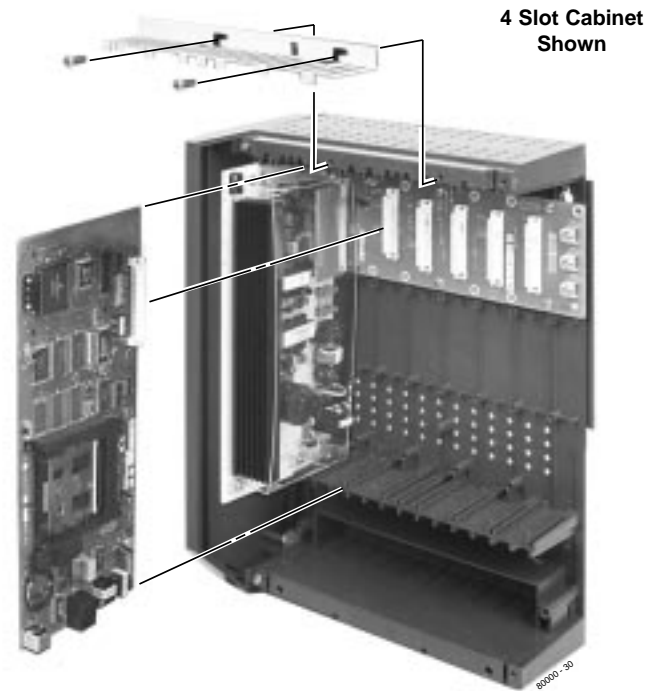

Figure 2-6 INSTALLING THE CPU

INSTALLING PCBs

Digital Station (16DSTU) PCB (Figures 2-6 and 2-7)

The 16DSTU provides connection for 16 digital telephones. Refer to *Section 3, Installing Extensions and Trunks* for wiring instructions.

● **To install the 16DSTU PCB:**

1. Plug the 16DSTU PCB for extensions 300-315 into slot CN1.
2. Plug in additional 16DSTU PCBs as required. See *System Configuration* in Section 1 for more.
3. Set the mode switch on each installed 16DSTU to RUN.

Mode Switch

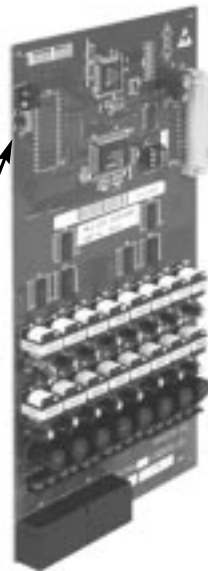

Figure 2-6 DIGITAL STATION (16DSTU) PCB

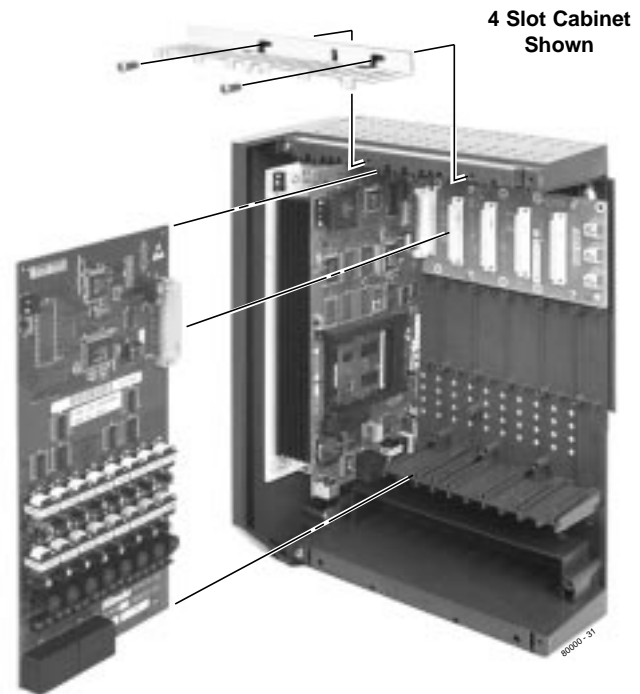

Figure 2-7 INSTALLING THE 16DSTU PCB

2-9

INSTALLING PCBS

Analog Station (8ASTU and 4ASTU) PCBs (Figures 2-8 and 2-9)

The 8ASTU PCB provides connection for 8 analog extensions. The 4ASTU PCB connects 4 analog extensions. Refer to *Section 3, Installing Extensions and Trunks* for wiring instructions.

● **To install the ASTU PCB:**

1. Plug in ASTU PCBs as required.
In U Slot systems, see System Configuration in Section 1.
In Fixed Slot systems, you can only plug an ASTU PCB into slot CN2.
An 8ASTU PCB provides analog extensions 316-323. A 4ASTU PCB provides analog extensions 316-319.
2. Set the mode switch on the ASTU to RUN.

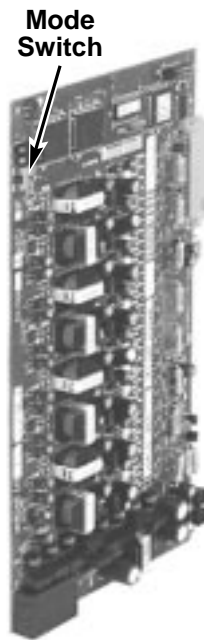

Figure 2-8 ANALOG STATION (ASTU) PCB

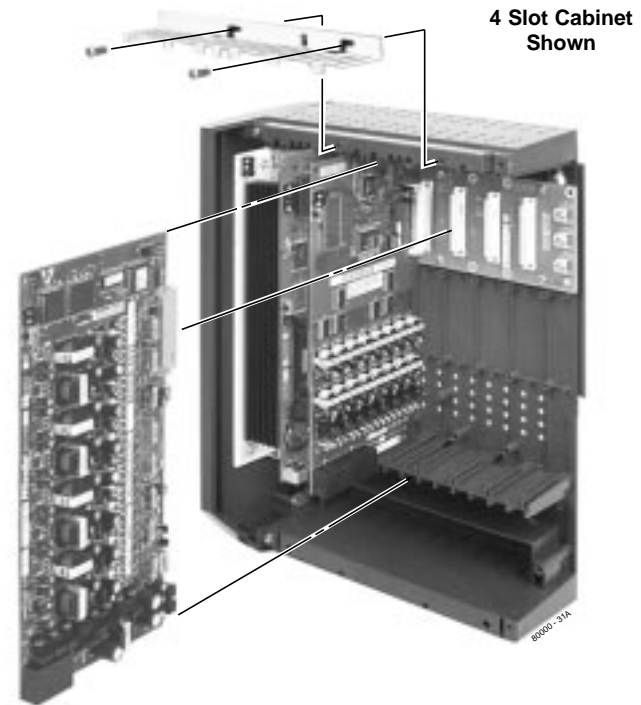

Figure 2-9 INSTALLING THE ASTU PCB

INSTALLING PCBs

Analog Trunk (8ATRU and 4ATRU) PCBs (Figures 2-10 and 2-11)

The 8ATRU provides connection for 8 loop start analog trunks. The 4ATRU PCB connects 4 loop start analog trunks. Refer to *Section 3, Installing Extensions and Trunks* for wiring instructions.

● **To install ATRU PCBs:**

1. Install ATRU PCBs as required.

In U Slot systems, see System Configuration in Section 1.

In Fixed Slot systems, plug the 8ATRU PCB for trunks 1-8 into slot CN3. Plug the 8ATRU PCB for trunks 9-16 into slot CN4.

In Fixed Slot systems, a 4ATRU PCB enables the first 4 trunks (1-4) but disables the second 4 (5-8).

With 2 4ATRU PCBs installed, you system has trunks 1-4 and 9-12.

3. Set the mode switch on each installed 8ATRU to RUN.

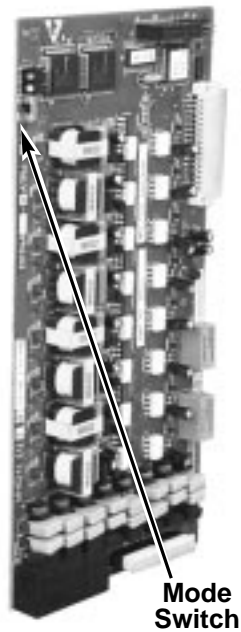

Figure 2-10 ANALOG TRUNK (ATRU) PCB

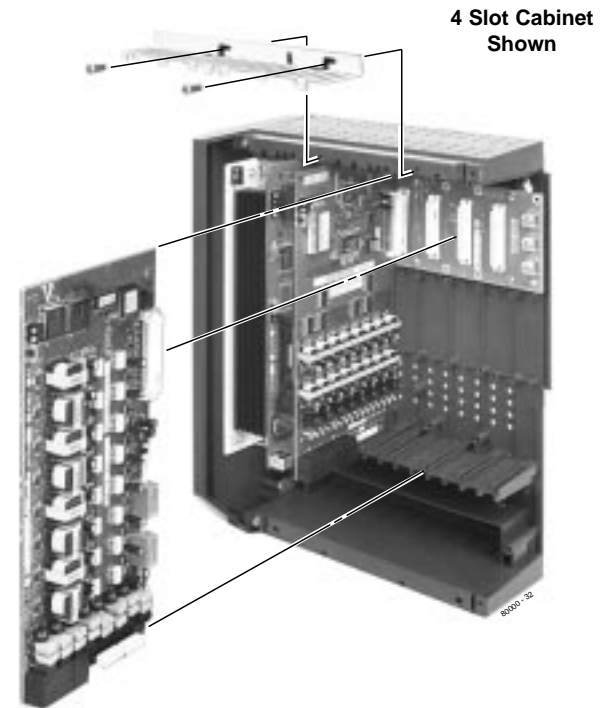

Figure 2-11 INSTALLING THE 8ATRU PCB

2-11

INSTALLING PCBs

8 Circuit Caller ID Daughter Board (Figure 2-12)

For Caller ID capability, install 8 circuit Caller ID PCB daughter boards (P/N 80013) on the 8ATRU PCBs (P/N 80011A). The Caller ID PCB provides Caller ID capability for all eight trunk circuits on the 8ATRU PCB. Every 8ATRU PCB in the system can have a Caller ID daughter board.

If you are installing Caller ID on an 8ATRU PCB in the last slot, you may have to adjust your system's ground wire connection so it won't obstruct the daughter board.

● To install ATRU PCBs:

1. Remove the metal bracket that holds the PCBs in place.
2. Remove the 8ATRU PCB.
3. Remove the headers from 8ATRU PCB connectors CN3 and CN4 and store in a safe place (see Figure 2-12).
4. Align the Caller ID PCB standoffs over the holes located in the 8ATRU PCB.

Note that the CN2 connector on the Caller ID PCB should be above the CN3 connector on the 8ATRU PCB. CN3 on the Caller ID PCB should be above CN4 on the 8ATRU PCB. CN1 on the Caller ID PCB should be above CN2.

5. Push the PCB down until the standoffs snap into place.
6. Plug the 8ATRU PCB back into the system cabinet.
7. Refer to your system's *Software Manual* for additional feature information and any required system programming.

INSTALLING PCBs

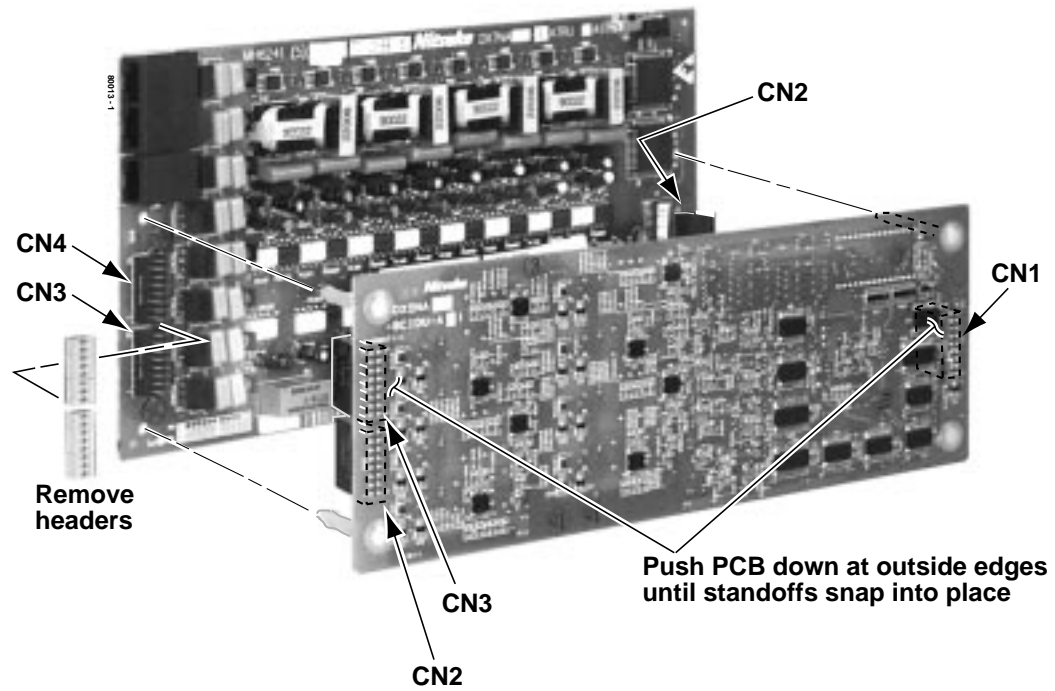

Figure 2-12 INSTALLING THE 8 CIRCUIT CALLER ID DAUGHTER BOARD

2. PCB Installation

INSTALLING PCBs

4 Circuit Caller ID Daughter Board (Figure 2-13)

For Caller ID capability, install 4 circuit Caller ID PCB daughter boards (P/N 92012) on the 4ATRU PCBs (P/N 80010A). The Caller ID PCB provides Caller ID capability for all four trunk circuits on the 4ATRU PCB. Every 4ATRU PCB in the system can have a Caller ID daughter board.

If you are installing Caller ID on a 4ATRU PCB in the last slot, you may have to adjust your system's ground wire connection so it won't obstruct the daughter board.

● To install ATRU PCBs:

If you install a P/N 92012 Caller ID PCB on an 8ATRU PCB P/N 80011A, you will get Caller ID service only on the first four PCB trunk circuits.

1. Remove the metal bracket that holds the PCBs in place.
2. Remove the 4ATRU PCB.
3. Remove the headers from 4ATRU PCB connector CN3 and store in a safe place (see Figure 2-13).
4. Align the Caller ID PCB standoffs over the holes located in the 4ATRU PCB.

Note that the CN2 connector on the Caller ID PCB should be above the CN3 connector on the 4ATRU PCB. CN1 on the Caller ID PCB should be above CN2.

5. Push the PCB down until the standoffs snap into place.
6. Plug the 4ATRU PCB back into the system cabinet.
7. Refer to your system's *Software Manual* for additional feature information and any required system programming.

INSTALLING PCBs

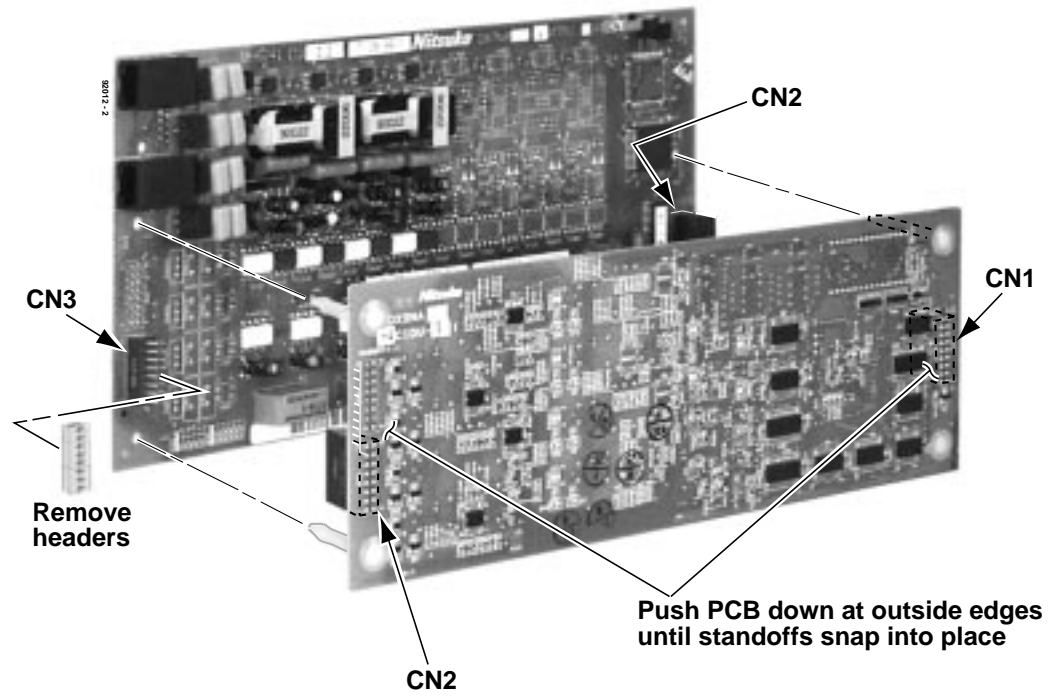

Figure 2-13 INSTALLING THE 4 CIRCUIT CALLER ID DAUGHTER BOARD

CONNECTING BLOCKS

Working With 8-Pin Jacks

The system uses 8-pin mod jacks to connect extensions, trunks and optional equipment. Using the Installation Cable (P/N 80892) makes it easy to connect the PCBs to standard 66M1-50 connecting blocks. These cables have 6 8-pin modular jacks on one end and are unterminated on the other. In general, each cabinet needs:

- One 66M1-50 block and Installation Cable (P/N 80892) for extensions and optional equipment.
- One 66M1-50 block and Installation Cable (P/N 80892) for trunks.

Note: Depending on your PCB configuration and local codes, you may need an additional 66M1-50 block and Installation Cable (P/N 80892) for optional equipment.

Punching Down the Cables (Figures 2-14 to 2-18)

The Installation Cables have 6 8-pin jacks installed on one end and are unterminated on the other. Each 8-pin jack connects 4 extensions or 4 trunks.

1. For each 66M1-50 block, punch down the Installation Cable in standard color-code order.
 - Use Figure 2-14 when connecting extensions.
 - Use Figure 2-15 when connecting trunks.
2. After you have punched down your cables, route them through the side of the cabinet and secure them with the strain relief (Figure 2-16).
3. If you are using non-A PCBs (e.g., 16DSTU PCB P/N 80021) in a 4 Slot Cabinet, be sure to install RFI Suppressor Assemblies on each station and trunk cable. Follow Figure 2-17 and snap an assembly around each 50-pin cable.

You cannot use non-A PCBs in an 8 Slot Cabinet.

Making your own Cables (Figure 2-18)

If you want to make your own cables (instead of using Installation Cable P/N 80892), follow the pinouts in Figure 2-18.

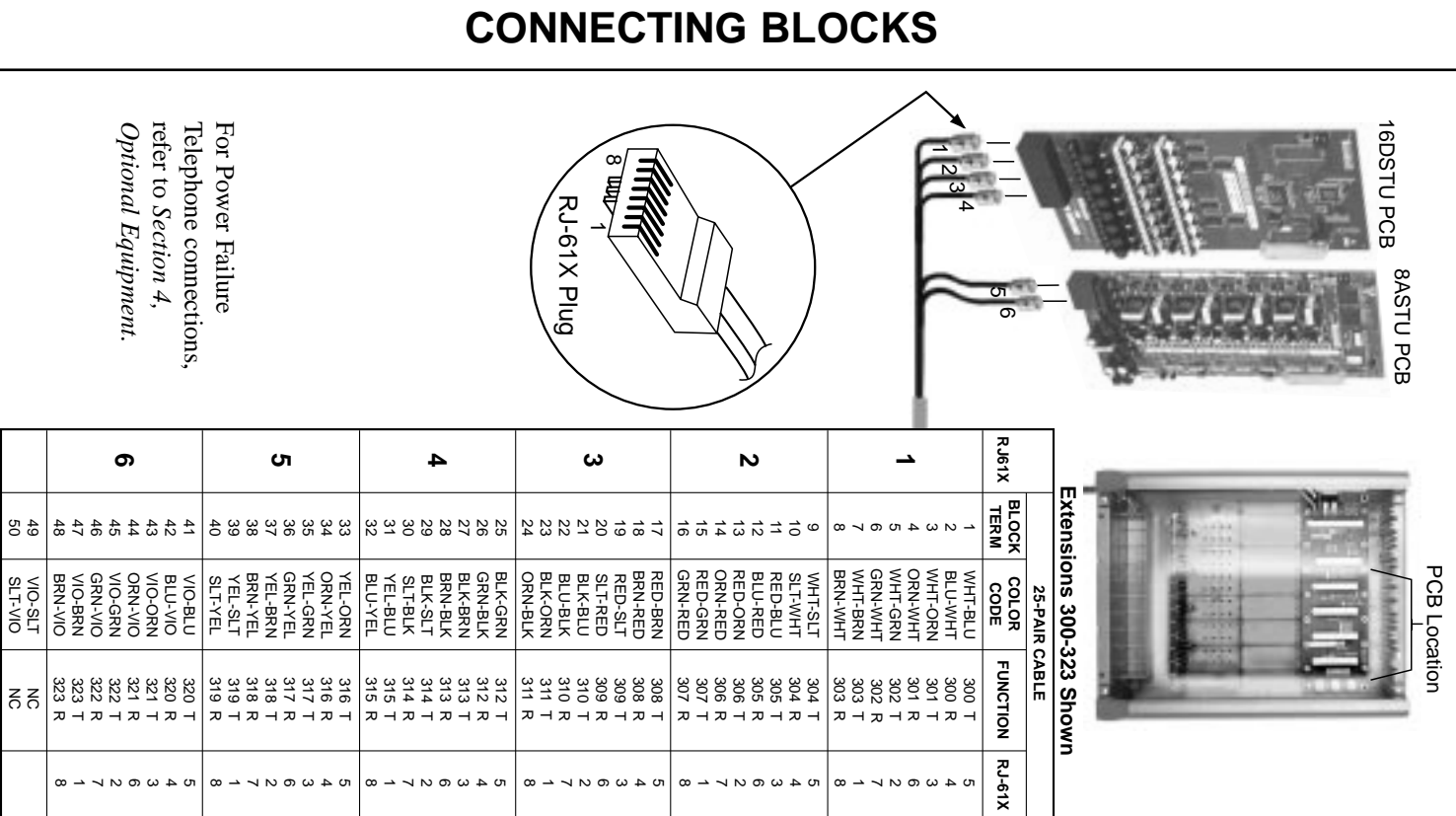
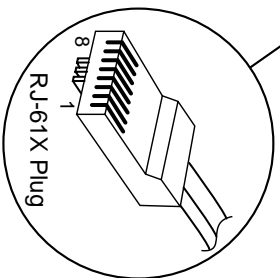
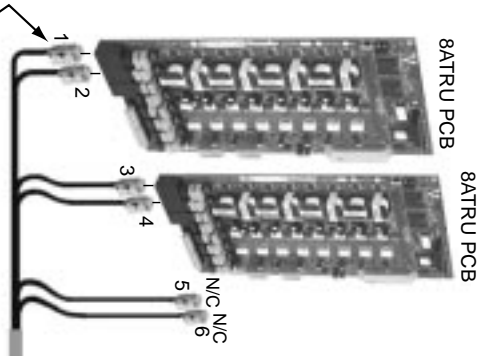
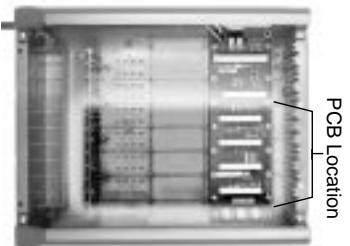

Figure 2-14 CONNECTING EXTENSIONS

2. PCB Installation

For Power Failure Telephone connections, refer to Section 4, *Optional Equipment*.



RJ61X	25-PAIR CABLE			RJ-61X
	BLOCK TERM	COLOR CODE	FUNCTION	
1	1	WHT-BLU	1 T	5
	2	BLU-WHT	1 R	4
	3	WHT-ORN	2 T	3
	4	ORN-WHT	2 R	6
	5	WHT-GRN	3 T	2
	6	GRN-WHT	3 R	7
	7	WHT-BRN	4 T	1
	8	BRN-WHT	4 R	8
2	9	WHT-SLT	5 T	5
	10	SLT-WHT	5 R	4
	11	RED-BLU	6 T	3
	12	BLU-RED	6 R	6
	13	RED-ORN	7 T	2
	14	ORN-RED	7 R	7
	15	RED-GRN	8 T	1
	16	GRN-RED	8 R	8
3	17	RED-BRN	9 T	5
	18	BRN-RED	9 R	4
	19	RED-SLT	10 T	3
	20	SLT-RED	10 R	6
	21	BLK-BLU	11 T	2
	22	BLU-BLK	11 R	7
	23	BLK-ORN	12 T	1
	24	ORN-BLK	12 R	8
4	25	BLK-GRN	13 T	5
	26	GRN-BLK	13 R	4
	27	BLK-BRN	14 T	3
	28	BRN-BLK	14 R	6
	29	BLK-SLT	15 T	2
	30	SLT-BLK	15 R	7
	31	YEL-BLU	16 T	1
	32	BLU-YEL	16 R	8
NC	33	YEL-ORN		5
	34	ORN-YEL		4
	35	YEL-GRN		3
	36	GRN-YEL		6
	37	YEL-BRN		2
	38	BRN-YEL		7
	39	YEL-SLT		1
	40	SLT-YEL		8
	41	VIO-BLU		5
	42	BLU-VIO		4
	43	VIO-ORN		3
	44	ORN-VIO		6
	45	VIO-GRN		2
	46	GRN-VIO		7
	47	VIO-BRN		1
	48	BRN-VIO		8
	49	VIO-SLT		
	50	SLT-VIO		

Figure 2-15 CONNECTING TRUNKS

CONNECTING BLOCKS

803037-20

CONNECTING BLOCKS

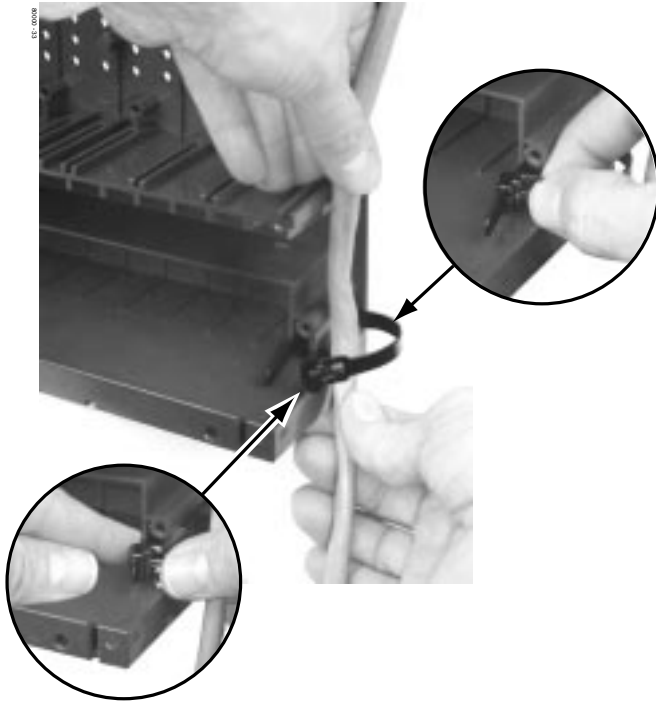

Figure 2-16 SECURING THE CABLES

2. PCB Installation

!! If you are using non-A PCBs in a 4 Slot Cabinet, install RFI Suppressor Assemblies on your station and trunk cables as shown below !!

The suppressors *must* be mounted inside the cabinet and as close to the appropriate PCB as possible.



Figure 2-17 INSTALLING THE RFI SUPPRESSOR

CONNECTING BLOCKS

The following products should help if you make your own cables:

- Suttle SE-266-8K 8 Position Modular Plug (requires an SE-166 or SE-166-6 modular crimping tool).
- Hubbell BRFTP4P Snap-On 8 Position Modular Plug (does not require a special crimping tool).

Check with your local supplier for other comparable products.

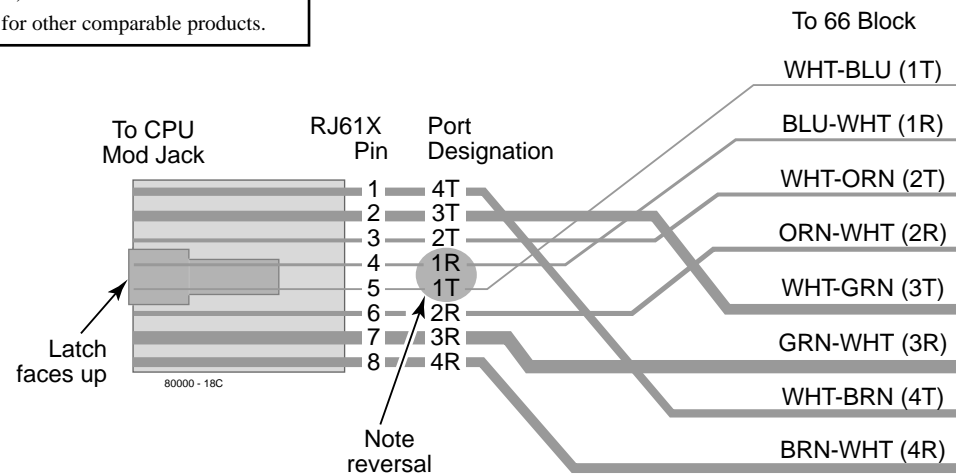

Figure 2-18 8-PIN (RJ61X) JACK PINOUTS

Section 3, INSTALLING EXTENSIONS AND TRUNKS

In this section . . .	Page
Connecting Extensions	3-2
Connecting Extensions	3-2
Connecting Trunks	3-3
Connecting Analog Trunks	3-3
Power Up and System LEDs	3-4
Power Up	3-4
Finishing the Installation	3-6
Reinstalling the Side Panel	3-6
Reinstalling the Front Cover	3-7

CONNECTING EXTENSIONS

Connecting Extensions (Figure 3-1)

Each 16DSTU PCB connects 16 digital extensions. Each 8ASTU PCB connects 8 analog extensions. Each 4ASTU PCB connects 4 analog extensions.

1. Using Figure 2-14 as a guide, insert the mod jacks into the appropriate connector on the PCB.
2. Install a modular jack for each extension within 6 feet of the telephone's location.
3. For each extension, run one-pair 24 AWG station cable from the cross-connect block to the modular jack.
4. Terminate the station cable WHT/BLU - BLU/WHT leads to the RED and GRN lugs in the modular jack.
5. Back at the main equipment location, run one pair of cross-connect wire between the pins on the B block and cross-connect block to complete the connection.
6. Install bridging clips as required.

You can also connect analog extensions to 2-OPX modules. See page 4-16 for more.

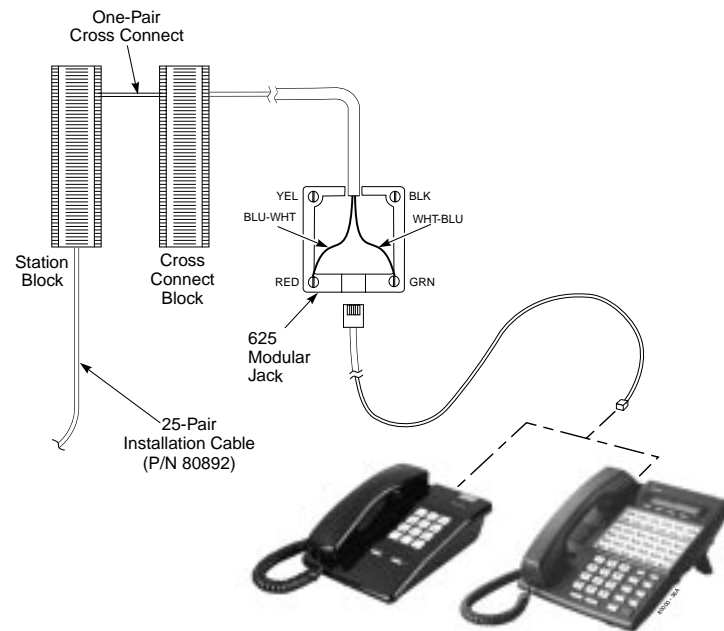

Figure 3-1 CONNECTING EXTENSIONS

CONNECTING TRUNKS

Connecting Analog Trunks (Figure 3-2)

Each 8ATRU PCB connects 8 loop start CO trunks. Each 4 ATRU PCB connects 4 loop start CO trunks.

In Fixed Slot systems, a 4ATRU PCB enables the first 4 trunks (1-4) but disables the second 4 (5-8). With 2 4ATRU PCBs installed, your system has trunks 1-4 and 9-12.

1. Using Figure 2-15 as a guide, insert the mod jacks into the appropriate connector on the PCB.
2. For each trunk, run one pair cross-connect wire between the pins on the cross-connect block and the CPE (customer side) of the telco's RJ21X.
3. Install bridging clips as required.

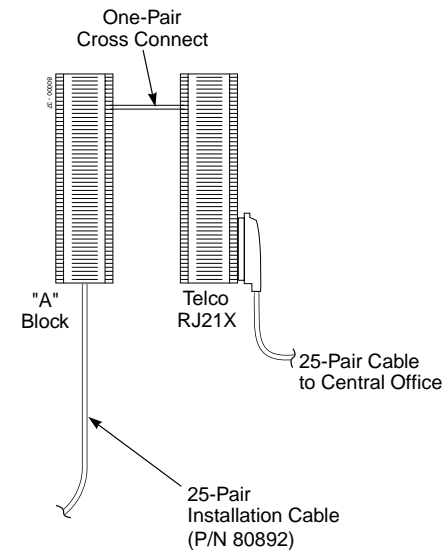

Figure 3-2 CONNECTING ANALOG TRUNKS

3-3

POWER UP AND SYSTEM LEDS

Power-Up (Figures 3-3 to 3-5)

Now that all the PCBs you need are installed and you have cabled the system, you can now power-up. You do not need to reattach the right side panel before powering up the system. Leaving the right side panel removed makes the station and trunk cabling more accessible.

● To power up the system:

- 1. Make sure the system is properly grounded and the PCB bracket is reinstalled and secured.
- 2. Install surge protectors in the AC outlet you intend to use for system power.
- 3. Plug the main cabinet's AC power cord into its surge protector.
- 4. Turn on the main cabinet power switch.

After about 30 seconds, verify that the PCB LEDs agree with the illustrations at right and on page 3-5.

▣ indicates the LEDs normal (i.e., system OK) status.

+ 5 V DC (Green)
▣ On: +5 V DC power present
Off: +5 V DC power not present

- 5 V DC (Green)
▣ On: -5 V DC power present
Off: -5 V DC power not present

- 40 V DC (Green)
▣ On: -40 V DC power present
Off: -40 V DC power not present

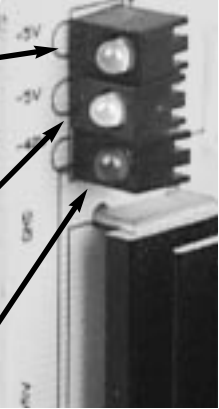
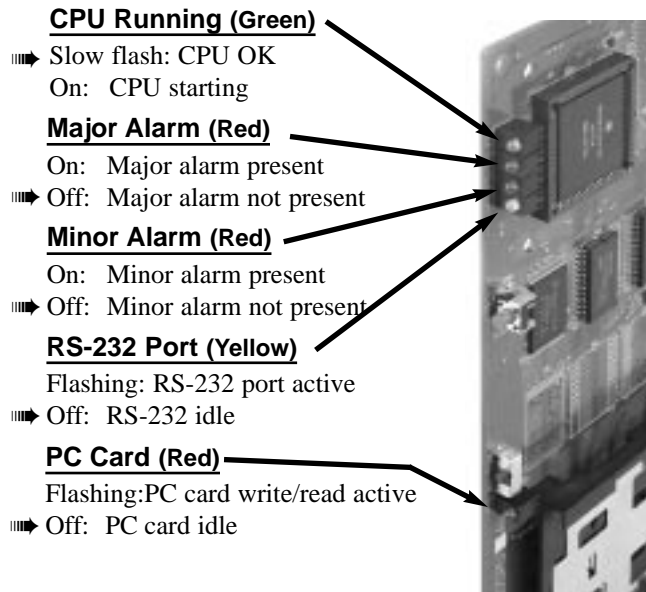

Figure 3-3 POWER SUPPLY STATUS LEDS

POWER UP AND SYSTEM LEDS

▣ indicates the LEDs normal (i.e., system OK) status.



3-4 CPU STATUS LEDS

▣ indicates the LEDs normal (i.e., system OK) status.

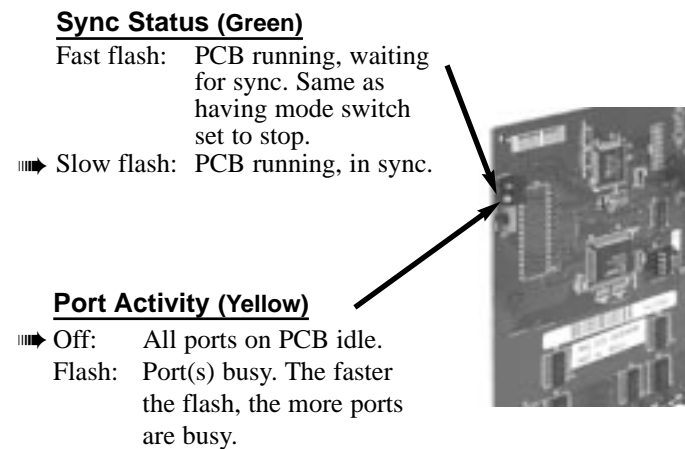

Figure 3-5 DSTU, ASTU and ATRU STATUS LEDS

3-5

FINISHING THE INSTALLATION

Reinstalling the Side Panel (Figure 3-6)

- **To reinstall the side panel:**

1. Carefully realign the right side panel and slide it into position.
2. Reattach the two screws that secure the right side panel to the cabinet.

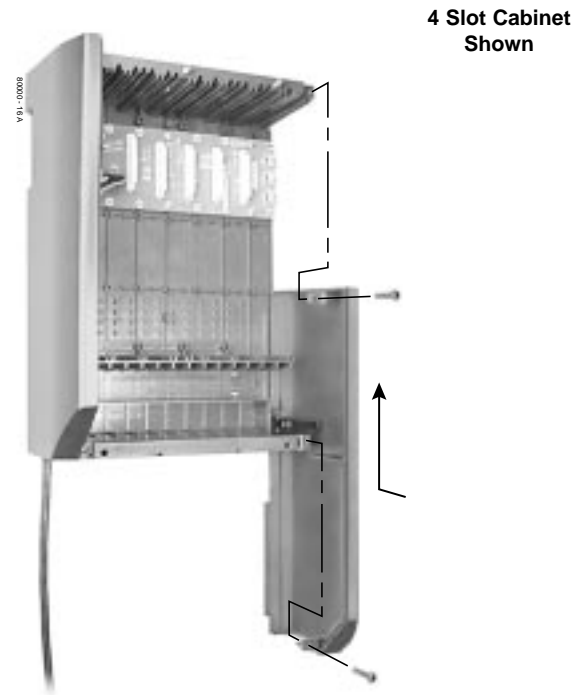

Figure 3-6 REINSTALLING THE SIDE PANELS

FINISHING THE INSTALLATION

Reinstalling the Front Cover (Figure 3-7)

● **To reinstall the front cover:**

1. Hook the tabs on the rear of the cover into their associated slots.
2. Push the front of the cover into place.
3. Screw in the two captive screws that secure the cover to the cabinet.

4 Slot Cabinet
Shown



Figure 3-7 REINSTALLING THE FRONT COVER

3-7

— For Your Notes —

Section 4, INSTALLING OPTIONAL EQUIPMENT

In this section . . .	Page
External Paging	4-2
Installing External Paging	4-2
Door Box	4-4
Installing the Digital Door Box	4-4
Programming the Digital Door Box	4-6
Operating the Digital Door Box	4-7
CPRU Relays	4-8
Connecting to the CPRU Relays	4-8
Music Sources	4-10
Installing a Music Source	4-10
Programming Background Music	4-10
Programming Music on Hold	4-10
Power Failure Telephones	4-12
Power Failure Cut-Through	4-12

In this section . . .	Page
DSS Console	4-14
Installing a DSS Console	4-14
Programming DSS Consoles	4-14
2-OPX Module	4-16
Installing the 2-OPX Module	4-16
Programming 2-OPX Modules	4-16
Wall Mounting the 2-OPX Module	4-18
Wall-Mount Kit	4-20
Installing the Wall-Mount Kit	4-20
Installing the Wall-Mount Handset Hanger	4-20
Wall-Mounting a Key Telephone	4-21
Desk Stand	4-25
Using the Desk Stand	4-25
REJ Recording Jack	4-26
Installing the REJ Recording Jack	4-26

EXTERNAL PAGING

Installing External Paging (Figure 4-1)

The CPU provides an External Paging output. You connect the CPU Paging output to audio inputs on customer provided Paging systems.

● **To connect an External Paging amplifier:**

1. Find an available connector in a station cable and make sure it is correctly punched down at the 66M1-50 block.

Follow standard color code order. Be sure the block is properly cross-connected.

2. For the connector chosen, locate pins 1T and 1R (see Figure 4-1) and connect the music source.
3. Plug the modular jack into the CPU modular connector.

Be sure the connected Paging equipment is compatible with the following CPU page output specifications:

Output Impedance: 600 Ohms

Output Level: 0 dBr @ 1.0 kHz

EXTERNAL PAGING

The following products should help if you make your own cables:

- Suttle SE-266-8K 8 Position Modular Plug (requires an SE-166 or SE-166-6 modular crimping tool).
- Hubbell BRFTP4P Snap-On 8 Position Modular Plug (does not require a special crimping tool).

Check with your local supplier for other comparable products.

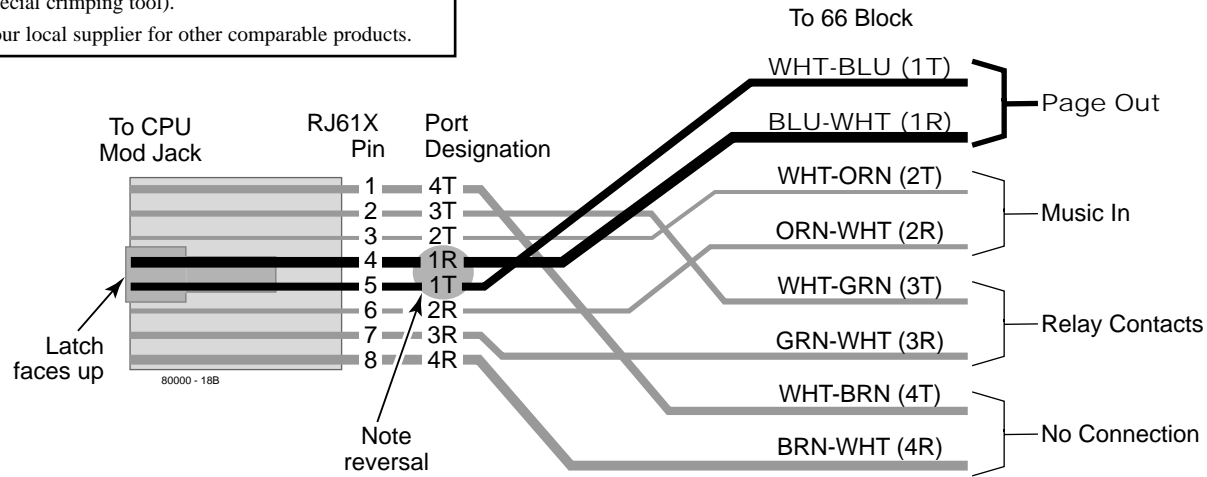

Figure 4-1 CONNECTING EXTERNAL PAGING

DOOR BOX

Installing the Digital Door Box (Figure 4-2)

The Digital Door Box (P/N 80560) is a self-contained Intercom unit typically used to monitor an entrance door. A visitor at the door can press the Door Box call button (like a door bell). The Door Box then sends chime tones to all extensions programmed to receive chimes. To answer the chime, the called extension user just lifts the handset. This lets the extension user talk to the visitor at the Door Box. The Door Box is convenient to have at a delivery entrance, for example. It is not necessary to have company personnel monitor the delivery entrance; they just answer the Door Box chimes instead.

The number of Door Boxes you can install is limited by the System Load Factor. (see page 1-16).

The Door Box is a weather-tight unit, with an operating temperature range of 0 to 45 degrees C (32 to 113 degrees F) and a relative humidity of 10-95%, non-condensing. It is not intended for outdoor installation.

Any available 16DSTU PCB port can support a Digital Door Box.

● To install the Digital Door Box:

1. Snap open the Door Box case.
2. Punch down one end of a two-pair twisted station cable on the extension block as shown in Figure 4-2.
3. Run the station cable through the hole in the back of the Door Box.

When wall mounting, use the two holes in the base of the Door Box for the mounting screws.

4. Strip the conductors back about 1/2 inch and connect to the Door Box terminals.
5. Snap the Door Box cover back onto the base.

Also see *Programming the Door Box* on page 4-6 and *Operating the Door Box* on page 4-7.

DOOR BOX

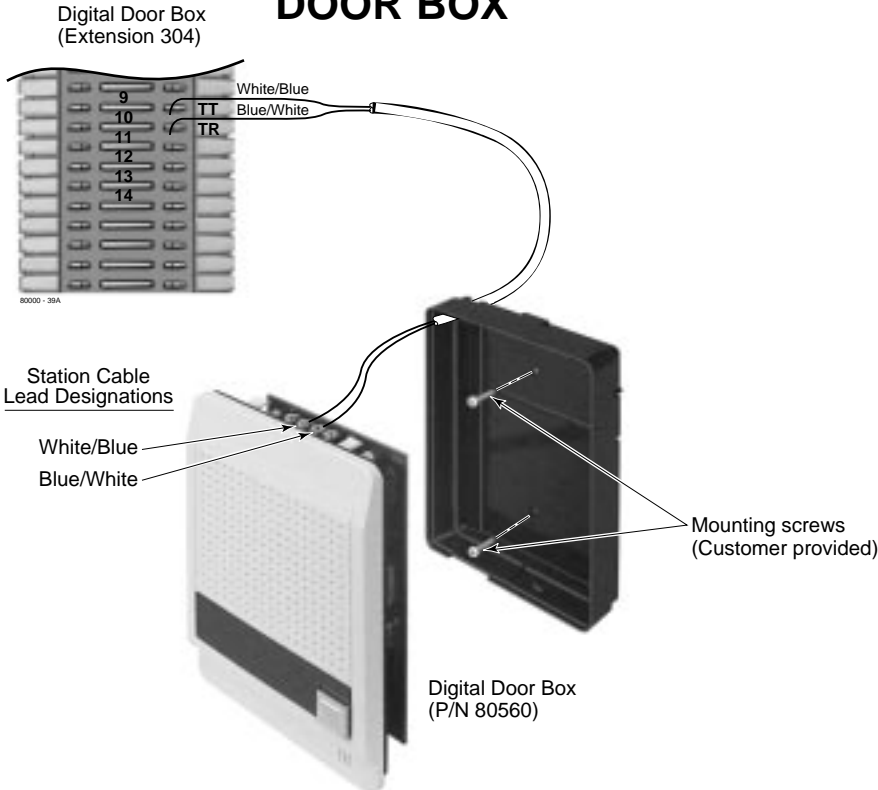

Figure 4-2 CONNECTING A DOOR BOX

4. Optional Equipment

DOOR BOX

Programming the Digital Door Box

Door Box Setup

You must assign the circuit type and chime pattern to each installed Door Box.

- In **1801: Extension Circuit Type**, enter 10 to assign the extension as a Door Box.
- In **1801: Door Chime**, enter the Door Chime type.

0 = Normal Ring Group ringing.

1 = Low pitch chime pattern.

2 = Mid range pitch chime pattern.

3 = High pitch chime pattern.

If you enter Door Chime type 0 (normal ring) above, you can set up Call Coverage keys for the Ring Group. This allows extensions that are not members of the Ring Group to answer Door Box calls. Extensions with Call Coverage keys to the Door Box Ring Group can also activate the relay (see Door Box Relay Control below).

Door Box Ringing

When a visitor at the door presses the Door Box call button, the Door Box with alert (chime) all the extensions in the Ring Group to which the Door Box belongs. For example, if the

Door Box and extensions 301 and 302 are in Ring Group 1, pressing the call button alerts 301 and 302.

- In **1802: Ring Group Number**, assign the Door Box and the extensions that should alert to the same Ring Group.
- In **0511: Ring Group Master Extension Numbers and Names**, assign a Ring Group master number to the Ring Group assigned in the previous step.

Door Box Relay Control

If the relay on the CPRU controls the strike for the door, the keyset that answers the Door Box chimes can remotely open and close the strike. Refer to *Connecting to the CPRU Relays* on page 4-8 for more on setting up this option.

- In **1801: Relay Owner**, enter 1 to assign the CPRU PCB relay to the Door Box (see Operating the Door Box below). Enter 0 to disable the CPRU PCB relay for Door Box calls.
- In **0401: Door Unlock Time**, enter the interval that the CPRU relay should remain closed after the keyset user activates (closes) the relay. After this interval, the CPRU automatically returns to its idle (open) state.

DOOR BOX

Operating the Door Box

To place a call from the Door Box:

1. Press the Door Box call button.
2. When someone inside the building answers your call, speak toward the Door Box.

To place a call to the Door Box:

1. Lift handset and press **ICM**.
2. Dial the Door Box extension number.

To answer the Door Box chimes from a keyset:

1. Lift handset or press **SPK**.

To control the CPRU relay which in turn controls the door strike:

Once set up in programming, this option is available to any member of the Door Box Ring Group as well as any extension with a Call Coverage Key for the Door Box Ring Group.

1. To open the relay, press **FLASH** key or **OPEN** soft key.
2. To close the relay, press **FLASH** key again or **CLOSE** soft key.

CPRU RELAYS

Connecting to the CPRU Relays (Figure 4-3)

Any keyset extension that receives Door Box chimes can control the CPRU relay, which in turn typically enables an electric strike on an entrance door next to a Door Box. After answering the Door Box chimes, the extension user can press a FLASH or a soft key to enable the associated relay. The visitor at the door can then enter without having an employee open the entrance for them.

● **To connect to the CPRU Relays:**

1. Find an available connector in a station cable and make sure it is correctly punched down at the 66M1-50 block.

Follow standard color code order. Be sure the block is properly cross-connected.

2. For the connector chosen, locate pins 3T and 3R (see Figure 4-3) and connect to the device the relays will control.
3. Plug the modular jack into the CPU modular connector.

Be sure the equipment connected to the relays is compatible with the following CPU relay specifications:

Contact Configuration . . .Normally open

Maximum Load60 mA @ 30 VDC
10 mA @ 90 VDC

Maximum Initial Contact Resistance . .50 mOhms

CPRU RELAYS

The following products should help if you make your own cables:

- Suttle SE-266-8K 8 Position Modular Plug (requires an SE-166 or SE-166-6 modular crimping tool).
- Hubbell BRFTP4P Snap-On 8 Position Modular Plug (does not require a special crimping tool).

Check with your local supplier for other comparable products.

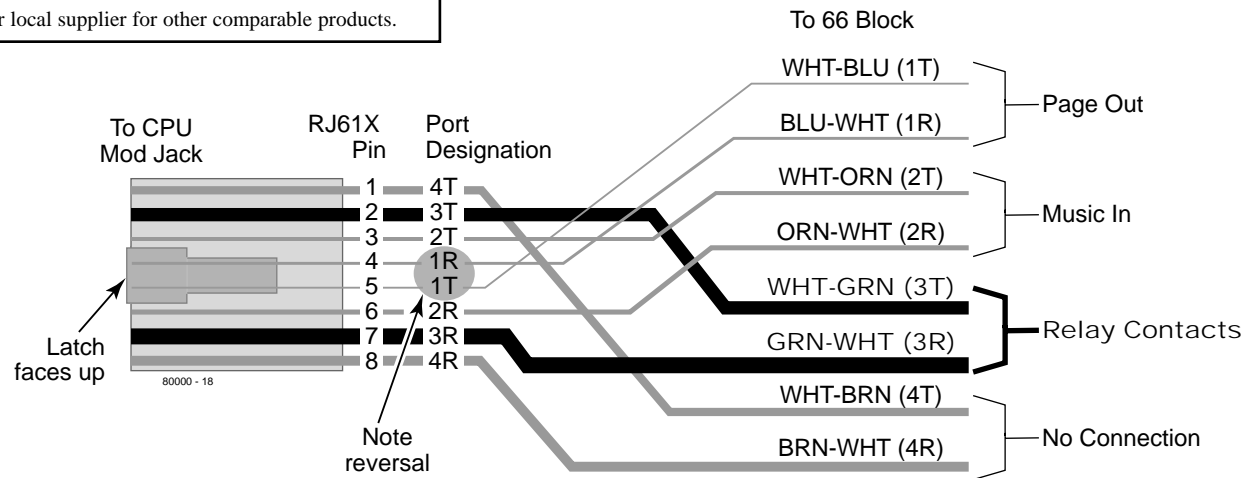

Figure 4-3 CONNECTING CONTROL RELAYS

4. Optional Equipment

MUSIC SOURCES

Installing a Music Source (Figure 4-4)

The CPU provides connection for a customer provided music source. Use this music source for Background Music and Music on Hold.

● **To connect a music source:**

1. Find an available connector in a station cable and make sure it is correctly punched down at the 66M1-50 block.

Follow standard color code order. Be sure the block is properly cross-connected.

2. For the connector chosen, locate pins 2T and 2R (see Figure 4-4) and connect the music source.
3. Plug the modular jack into the CPU modular connector.

Be sure the connected music source is compatible with the following CPU music input specifications:

Input Impedance: 10K Ohms
Output Level: +18 dBr (+/- 2 dBr) @ 1.0 kHz

Programming Background Music

● **0201: Background Music**

Enter Y to enable Background Music system-wide.

● **1802: BGM**

Enter Y to enable Background Music at the extension.

Programming Music on Hold

● **0201: Music on Hold**

Enter Y to enable Music on Hold system-wide.

● **0201: MOH on Transfer**

Enter Y to enable Music on Hold for transferred calls.

MUSIC SOURCES

- The following products should help if you make your own cables:
- Suttle SE-266-8K 8 Position Modular Plug (requires an SE-166 or SE-166-6 modular crimping tool).
 - Hubbell BRFTP4P Snap-On 8 Position Modular Plug (does not require a special crimping tool).
- Check with your local supplier for other comparable products.

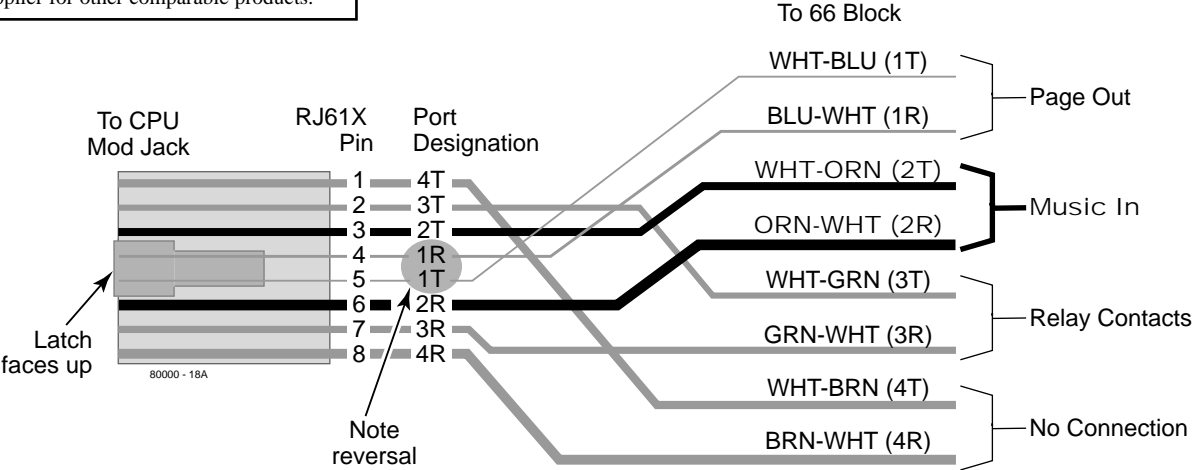

Figure 4-4 INSTALLING A MUSIC SOURCE

4. Optional Equipment

POWER FAILURE TELEPHONES

Power Failure Cut-Through (Figure 4-5)

When system AC power fails, the 8ATRU PCB automatically cuts through the first 2 trunk circuits to 2 Power Failure Telephone connections.

● To install Power Failure Cut-Through:

1. Locate an available 8-pin jack in a trunk (A) block or station (B) block.

Local codes may prevent you from using a DDK connector on the A block for optional equipment.

2. For the 8-pin jack chosen, cross-connect the associated wire pair from the A or B block to the cross-connect block.
3. Install a modular jack for each Power Failure Telephone within six feet of the telephone's location.
4. For each Power Failure Telephone, run one-pair of 24 AWG station cable from the cross-connect block to the telephone's modular jack.
5. Terminate the station cable WHT/BLU - BLU/WHT leads to the RED and GRN lugs in the modular jack.
6. Install bridging clips as required.

● To test the Power Failure Telephone:

1. Connect a Power Failure Telephone per Figure 4-5.
2. Power down the system.
3. At the Power Failure Telephone, lift the handset.

You should hear dial tone on the trunk you connected in Figure 4-5.

4. Place a test call.

If power is restored while a cut-through call is in progress, the call is maintained until the user hangs up the Power Failure Cut-Through telephone.

POWER FAILURE TELEPHONES

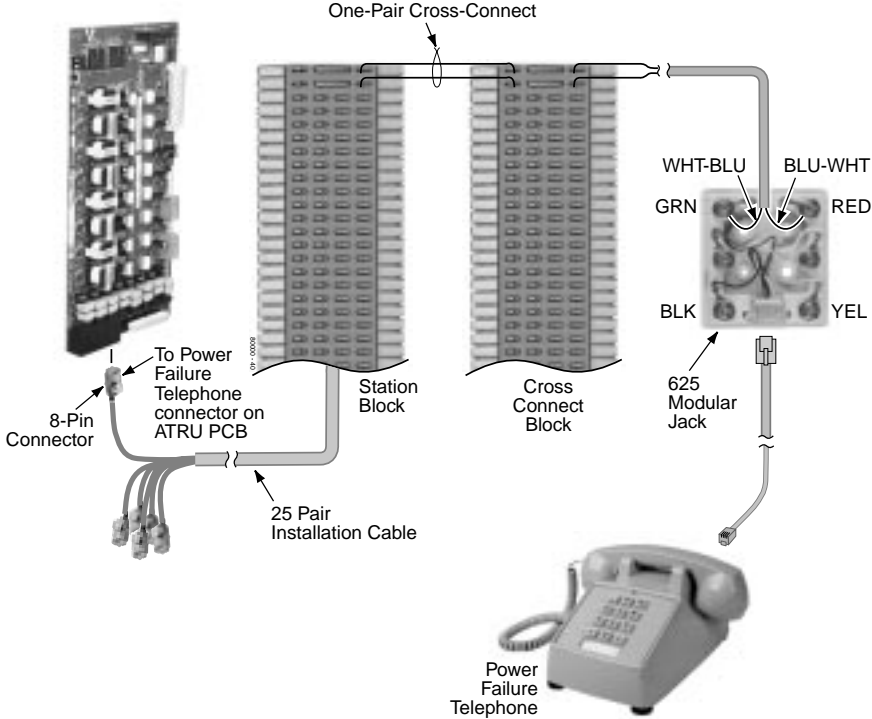

Figure 4-5 CONNECTING A POWER FAILURE TELEPHONE

4. Optional Equipment

DSS CONSOLE

Installing a DSS Console (Figures 4-6 and 4-7)

The DSS Console gives a keyset user a Busy Lamp Field (BLF) and one-button access to extensions, trunks and system features. Keep the following in mind when installing DSS Consoles:

- You can only connect 4 DSS Consoles.
 - You can only connect DSS Consoles to Super Display or 34-Button Display telephones.
 - A DSS Console does not require a separate station port – it connects directly to the keyset.
- **To install a DSS Console:**
1. Turn the telephone upside down and remove the plastic filler plug from the DSS modular connector.
 2. Plug the DSS Console's 8-pin modular line cord into the telephone's DSS connector.
 3. Plug the other end of the 8-pin line cord into the DSS Console's 8-pin jack.
 4. If you have a 24-Button DSS Console, attach the metal plate to both the DSS Console and telephone as shown.

Programming DSS Consoles

● **1801: DSS Type**

For the extension to which you have connected the DSS Console, enter 1 for 24-button, 2 for 110-button and 0 for unassigned.

● **1801: DSS Block Number**

For the extension to which you have connected the DSS Console, enter the number of the block that corresponds to the connected console. A block is a unique DSS Console assignment. The system provides up to 4 blocks; one for each console.

Your consoles can share the same block if you want them to have the same programming. They will still have unique Personal Speed Dial numbers, since a DSS Console uses the Personal Speed Dial for the extension to which it is attached.

● **1704: DSS Console Key Assignment**

Program the DSS Console's keys. Refer to the software manual for additional programming details.

DSS CONSOLE

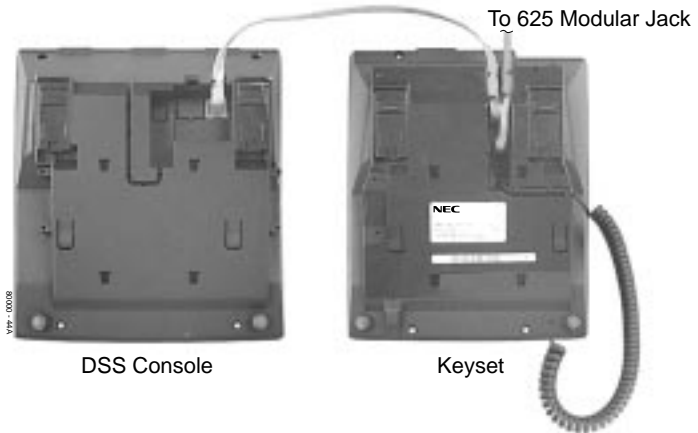

Figure 4-6 INSTALLING A 110-BUTTON DSS CONSOLE

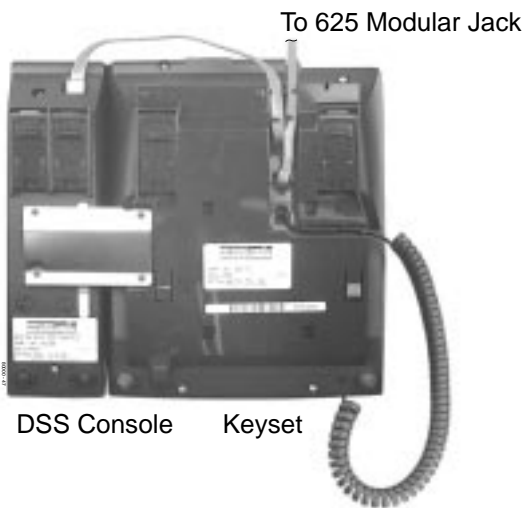

Figure 4-7 INSTALLING A 24-BUTTON DSS CONSOLE 4-15

4. Optional Equipment

2-OPX MODULE

Installing the 2-OPX Module (Figure 4-8)

The 2-OPX Module (P/N 92177A) provides two 2500 type analog circuits for connection to on-premise 2500 type single line devices (i.e., telephones, fax machines, modems, etc.) and to telco OL13B/C OPX circuits. It uses a single digital extension circuit for the power and signaling for both analog ports.

● To install a 2-OPX Module:

1. Locate an 8-pin modular connector in a trunk block or station block.
Local codes may prevent you from using a connector on the trunk block for optional equipment.
2. For the connector chosen, cross-connect the associated wire pair from the trunk or station block to the cross-connect block.
3. Install a modular jack for the 2 OPX Module within six feet of the module's location.
4. Run one-pair 24 AWG station cable from the cross-connect block to the modular jack.
5. Terminate the station cable WHT/BLU - BLU/WHT leads to the RED and GRN lugs in the modular jack.
6. Install bridging clips as required.

7. Ground the 2-OPX Module by connecting a 12 AWG ground wire from the FG lug to a known earth ground.
8. Plug a line cord into the 2-OPX unit and the 2-OPX's modular jack.

The DS1 LED on the 2-OPX Module lights steadily.

Programming 2-OPX Modules

● 1801: Extension Circuit Type

Assign the 2-OPX extension circuit type 21.

The 2-OPX Module uses a single port.

Notes:

- Each 2-OPX Module provides 2 OPX ports. The first 2-OPX extension number is the same as the port's extension number. The second 2-OPX extension number is the first port **plus 201**. For example, the two extension numbers for the 2-OPX Module plugged into extension 314 are 314 and 515.
- In *fixed slot systems*, the above is true only for a 2-OPX connected to the first DSTU PCB in the system. When connected to the second DSTU PCB in the system, the first 2-OPX extension number is still the same as the port's extension number, but the second 2-OPX extension number is the first port **plus 217**. For example, the two extension numbers for the 2-OPX Module plugged into extension 316 are 316 and 533.4-16

2-OPX MODULE

Wall Mounting the 2-OPX Module (Figure 4-9)

1. Following the diagram below, move the screws that secure the 2-OPX Module cover from the outside holes to the inside holes. Do not tighten the screws.
2. Attach the wall mount brackets to each side of 2-OPX Module and tighten the screws.
3. With the connectors facing down, mount the 2-OPX Module to the wall using suitable customer-provided fasteners.
Use the 2-OPX Module as its own mounting template.
4. Connect the 2-OPX module as described on the previous page.

2-OPX MODULE

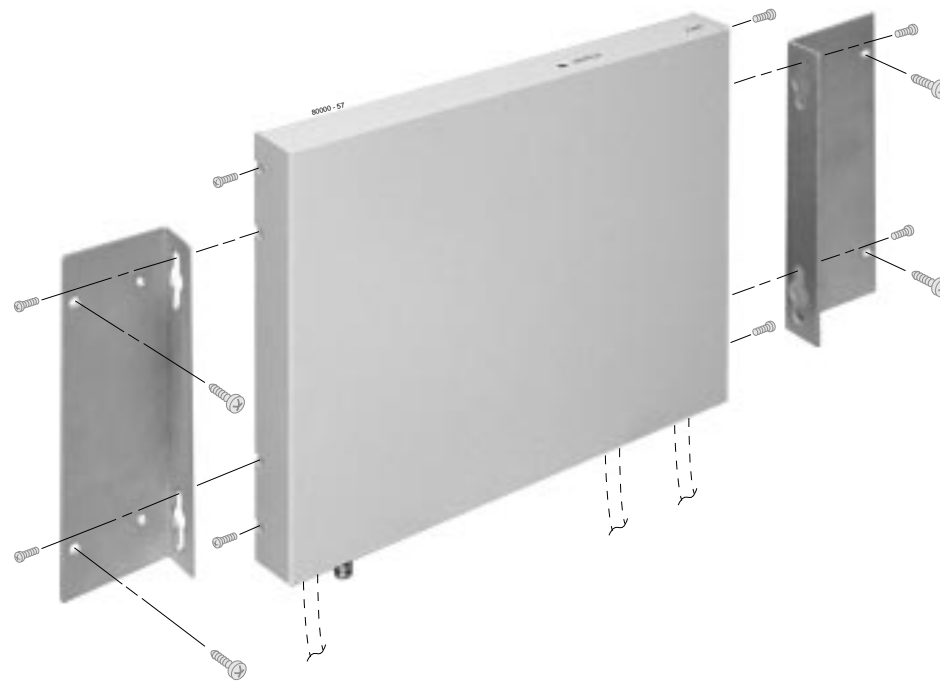

Figure 4-9 WALL MOUNTING THE 2-OPX MODULE

WALL-MOUNT KIT

Installing the Wall-Mount Kit

You can use a wall-mount kit to attach any key telephone to a wall. The wall-mount kit includes a mounting bracket, wall-mount screws and a handset hanger.

Installing the Wall-Mount Handset Hanger (Figure 4-10)

1. Remove the rubber plug that covers the slots for the handset hanger. Store the plug in a safe place.
2. Insert the handset hanger in the slot provided beneath the telephone's hookswitch.



Figure 4-10 INSTALLING THE WALL-MOUNT HANGER

WALL-MOUNT KIT

Wall-Mounting a Key Telephone (Figures 4-11 through 4-13)

- **To mount the telephone on the wall** (Figure 4-11):
 1. Using the screws provided, attach the wall-mount bracket to the wall in the desired location.
 2. Plug in the telephone's modular line cord.
 3. Run the telephone's line cord through one of the slots in the bottom of the wall-mount bracket.
 4. Plug the line cord into the telephone's 625 modular jack.
 5. Place the telephone on top of the wall-mount bracket and snap into place.

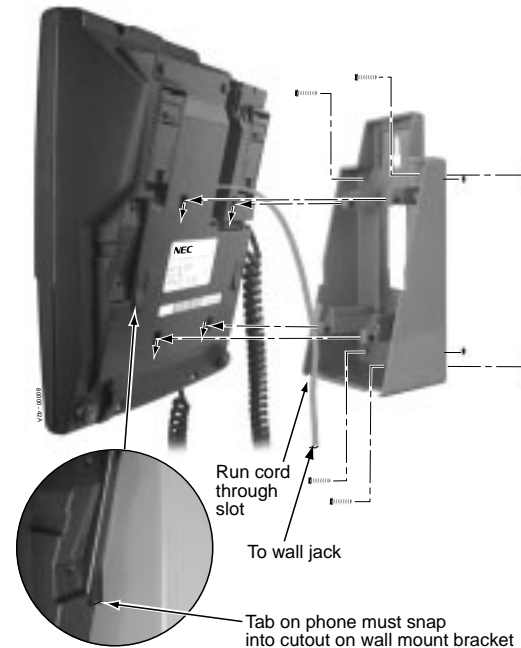

Figure 4-11 INSTALLING THE WALL MOUNT BRACKET

4-21

4. Optional
Equipment

WALL-MOUNT KIT

● **To mount the telephone on a wall plate** (Figure 4-12):

1. Snap the wall-mount bracket onto the wall plate.
2. Plug the telephone's line cord into the jack in the wall plate and into the telephone.
3. Place the telephone on top of the wall-mount bracket and snap into place.

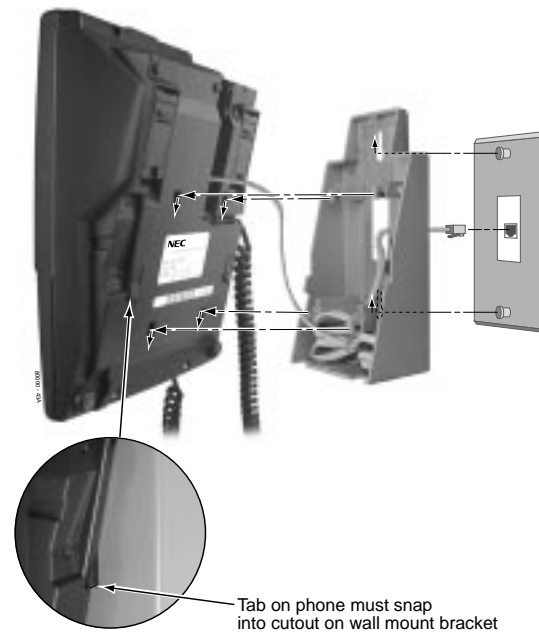

Figure 4-12 MOUNTING ON A WALL PLATE

WALL-MOUNT KIT

- **To remove the telephone from the wall mount kit**
(Figure 4-13):

1. From the front of the phone, grab the tabs that secure the telephone to the wall-mount kit.
2. While pressing in the tabs, lift up the phone until it snaps clear of the wall-mount kit.

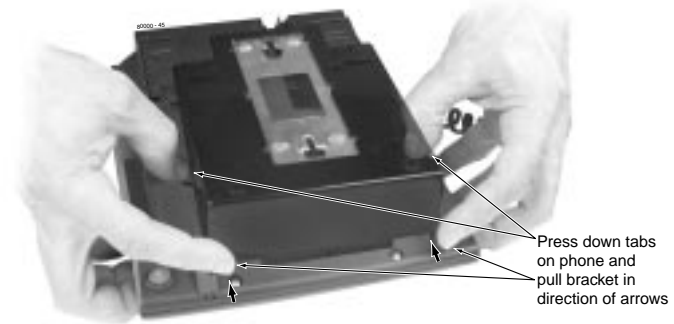

Figure 4-13 REMOVING THE WALL MOUNT BRACKET

4-23

— For Your Notes —

DESK STAND

Using the Desk Stand (Figure 4-14)

Each telephone has an integrated desk stand. You can extend the desk stand in one of two positions: low and high.

● **To use the desk stand low position:**

1. Flip up each telephone leg until it snaps into place.

● **To use the desk stand high position:**

1. Flip up each telephone leg into the low position.
2. Push out the leg extender.
3. Slide the extender up, then down until it locks in place as shown at right.

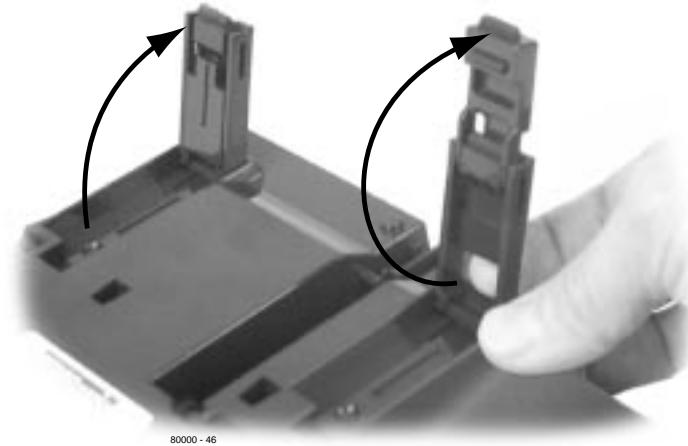

Figure 4-14 USING THE DESK STAND

REJ RECORDING JACK

Installing the REJ Recording Jack (Figure 4-15)

Use the REJ Recording Jack (P/N 80175) to connect a Super Display or 34-Button Display Telephone to an external tape recorder or amplifier. The REJ output is a mono sub-miniature jack which connects directly to an AUX level input. The REJ broadcasts both sides of your conversation (i.e., your voice and your caller's voice) whenever you lift your handset. The REJ does not broadcast Paging announcements or activate for Handsfree calls.

CAUTION

Be sure the connected audio device provides a standard AUX level input.

● To install the REJ Recording Jack:

1. Unplug the telephone line cord and handset cord, and turn the telephone face down on a non-abrasive surface.
2. Remove the 4 screws that secure the telephone base.
3. Separate the telephone faceplate from the telephone base.
4. On the left side of the telephone base, remove the plastic molding that covers the hole for the REJU connector. ***You only need to remove the top half of the molding.***
5. Install the REJ as shown (with the components facing down).
6. Secure with the supplied screw.

● To connect the REJ Recording Jack:

1. Route the REJ wires through the guides in the telephone base.
2. Plug the REJ cable into the connector in the telephone PCB.

The connector is keyed so you can't plug in the cable the wrong way.

3. Reassemble the telephone, plug in the handset, and reconnect the line cord.
8. Using an audio cable, connect the REJ to the amplifier's mono AUX input.

To connect to a stereo AUX input, use a commercially available mono-to-stereo splitter cable.

REJ RECORDING JACK

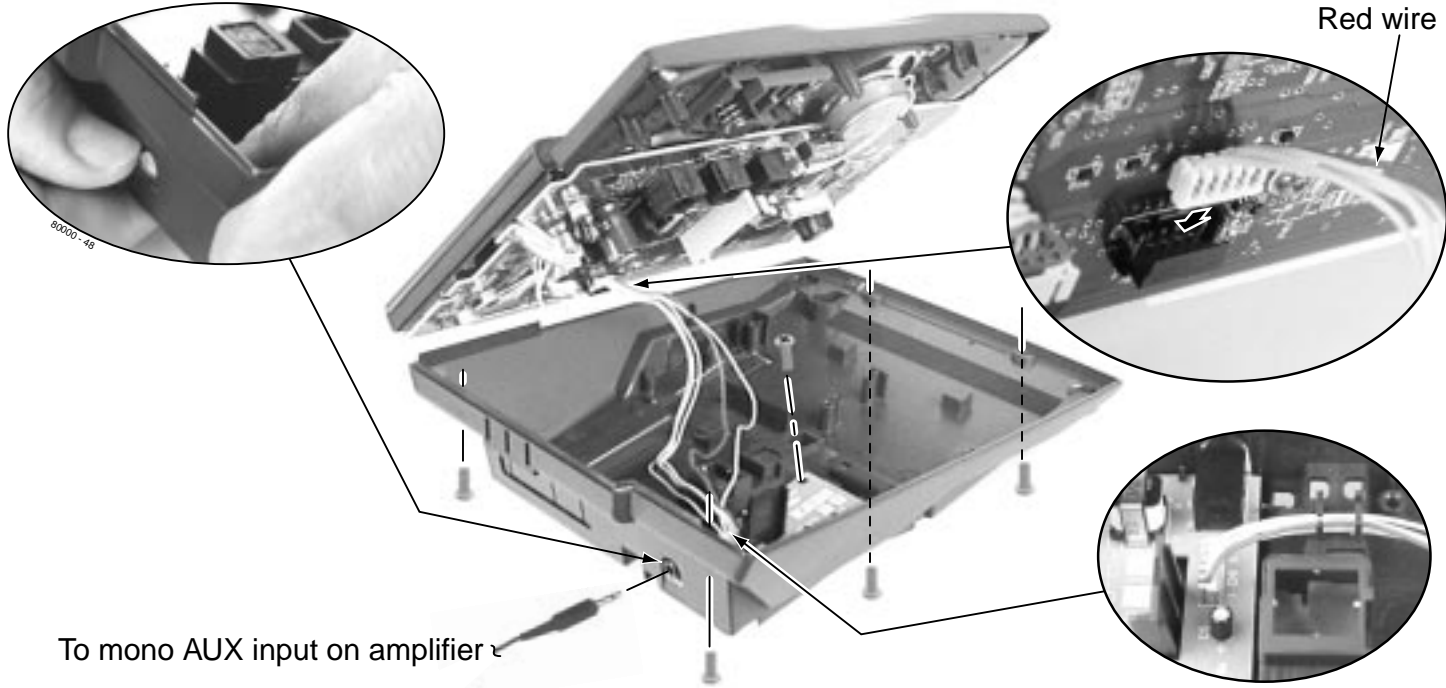

Figure 4-15 INSTALLING THE REJ

4. Optional Equipment

REJ RECORDING JACK

— For Your Notes —

Section 5, MAINTENANCE OPTIONS AND SMDR

In this section . . .	Page
Backing Up Site Data5-3
Backing Up Site Data with a PC Card	5-3
PC Card Backup Error Messages	5-5
Restoring Site Data5-6
Restoring Site Data from a PC Card	5-6
PC Card Restore Error Messages	5-6
Loading New System Software5-7
Loading System Software from a PC Card . . .	5-7

In this section . . .	Page
SMDR5-8
Installing SMDR	5-8
Programming SMDR	5-8
Modem Installation5-10
Installing a Modem	5-10
Making your own Data Cables5-12

PC Card Data Base Compatibility

Keep the following PC Card data base compatibility guidelines in mind when backing up and restoring site data:

U Slot Version 02.01.00 or Higher

- Use PC Card with Software P/N 80051-V02.**.** to load or upgrade your system software. Do not use PC Card with Software P/N 80050-V**.**.**.
- Use Blank PC Card P/N 85880 to store up to 16 system data bases. You cannot store data bases on PC Card with Software P/N 80051-V02.**.**.
- If restoring a data base from software version 02.00.00, the data base addresses are offset by 8. For example, a 02.00.00 data base you store in address 00 becomes address 08 in 02.01.00.
- All U Slot software version 02.**.** data bases in systems using CPU P/N 80025A are compatible (regardless of whether they are installed in a 4 or 8 slot cabinet).
- U Slot software version 02.**.** data bases in systems using CPU P/N 80025 **are not** compatible with data bases using CPU P/N 80025A.

U Slot Version 02.00.00

- Use PC Card with Software P/N 80050-V02.00.00 to load or upgrade your system software, or to store up to 12 system data bases. Do not use PC Card with Software P/N 80051-V**.**.**.
- You can also use Blank PC Card P/N 85880 to store up to 12 system data bases.

Fixed Slot Version 01.**.**

- Use PC Card with Software P/N 80050-V01.**.** to load or upgrade your system software, or to store up to 12 system data bases. Do not use PC Card with Software P/N 80050-V02.**.** or P/N 80051-V**.**.**.
- You can also use Blank PC Card P/N 85880 to store up to 12 system data bases.
- Fixed Slot data bases are not compatible with U Slot data bases. If you upgrade your system software from Fixed Slot to U Slot, you must use **9999 - System Initialization** to initialize your system.

BACKING UP SITE DATA

Backing Up Site Data with a PC Card (Figure 5-1)

You can use PC Card P/N 85880 to back up and restore your site data.

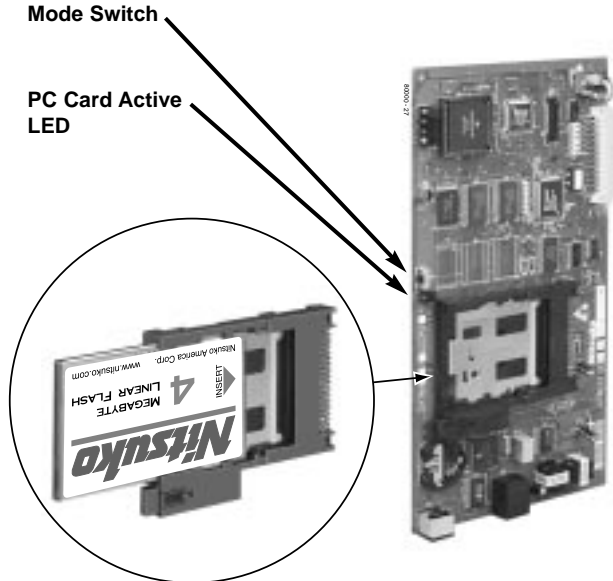

Figure 5-1 USING THE PC CARD

● To use the PC Card to back up site data:

1. Insert the PC Card into the CPU.
2. Be sure the CPU mode switch is set to **RUN**.
3. Enter the programming mode.
ICM + ##* + 372000 + HOLD*
4. Dial 9906 + HOLD.
You see: START?
To quit program 9906 instead, dial N + HOLD .
5. Dial Y + HOLD.
You see: 9906: DATABASE NAME
6. Enter a name for the database you want to save (up to 10 characters long).

*Refer to **Keys for Entering Names** on the next page if you need help when entering names.*

Skip this step if you want to save data in an address that already has a name assigned.



BACKING UP SITE DATA

Keys for Entering Names					
Press this key:	Then one of these keys to enter the character in the white cell:				
	1	2	3	4	#
1	&	-(dash) ¹	/(backslash) ¹	'(apostrophe) ¹	1
2	A	B	C		2
3	D	E	F		3
4	G	H	I		4
5	J	K	L		5
6	M	N	O		6
7	P	Q	R	S	7
8	T	U	V		8
9	W	X	Y	Z	9
0	SPACE	:			0
*					*
#					#

To enter characters in lower case (e.g., **e** instead of **E**), press **MW** before pressing the key in the first shaded column. Use **LND** to backspace over (erase) any characters you want to correct.

¹In software versions prior to 02.00.00, the codes for 1 + 2, 1 + 3, and 1 + 4 were not available.

Figure 5-2 ENTERING NAMES

7. When you are done entering the name, press HOLD.
You see the name and date of the first database stored.
If no data bases are stored, you see:
 9906: DB00
 (empty)
8. The system assigns the name you entered in step 7 to the data base address you select below:
 - Press VOL ▲ or VOL ▼ to scroll through the addresses.
 In software versions 02.00.01 and higher, there are 16 data base addresses: DB 00 to DB 15.
 - OR
 - Skip this step to select the currently displayed data base.
9. Press HOLD.
Normally, you see
 9906: SAVING
The PC Card Active LED is on during backup.
If the address you choose already has data stored in it, you see: REPLACE DB nn Y/N.
 - Press N + HOLD to back up to step 5.
 - Press Y + HOLD to proceed.*You automatically exit programming when the upload completes.*

BACKING UP SITE DATA

PC Card Backup Error Messages

This error message . . .	Means this . . .
NO PCCARD	The PC card is not installed. <i>Install the PC card and try again.</i>
ERASE FAILED	The system could not overwrite an existing data base on the PC card. <i>Repeat the procedure. If you get the message again, try another PC card.</i>
SAVE FAILED	The system could not save data to the PC card. <i>Repeat the procedure. If you get the message again, try another PC card.</i>

RESTORING SITE DATA

Restoring Site Data from a PC Card

● **To use the PC Card to restore site data:**

Review PC Card Data Base Compatibility on page 5-2.

1. Insert the PC Card into the CPU (see Figure 5-1).
2. Be sure the CPU mode switch is set to **RUN**.
3. Enter the programming mode.

ICM + ##* + 372000 + HOLD*

4. Dial 9907 + HOLD.

You see: START?

5. Dial Y + HOLD.

You see the name and date of the first database stored.

If no data bases are stored, you see:

9907: DB00

(empty)

6. Press VOL ▲ or VOL ▼ to scroll through the data base addresses and select the one you want to restore.

In software versions 02.00.01 and higher, there are 16 data base addresses: DB 00 to DB 15.

7. When the data base you want to restore displays, press HOLD.

The PC Card Active LED is on during restore.

You automatically exit programming when the upload completes.

PC Card Restore Error Messages

This error message . . .

Means this . . .

NO PCCARD

The PC card is not installed.

Install the PC card and try again.

NO DATABASE

There is not data stored in the data base address you selected.

Select another data base address and try again.

LOADING NEW SYSTEM SOFTWARE

Loading System Software from a PC Card

- To use the PC Card to load system software (P/N 80051-V**.**.**) only:

Review PC Card Data Base Compatibility on page 5-2.

Loading new system software will automatically reload the factory installed (default) program entries.

1. Insert the PC Card into the CPU (see Figure 5-1).
2. Be sure the CPU mode switch is set to **BOOT**.
3. Press the reset switch on the CPU to reset the system.

The LEDs on the CPU will start to cycle.

After about 1 minute, the system will restart with the new software loaded using the factory installed (default) entries. The LEDs on the CPU will then flash normally (see Figure 5-3).

4. Once the system restarts, switch the CPU mode switch to **RUN**.

▣ indicates the LEDs normal (i.e., system OK) status.

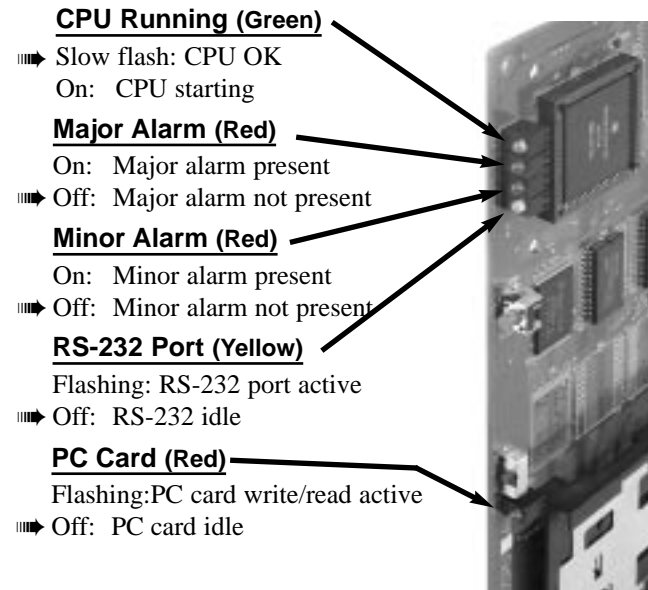

5-3 CPU STATUS LEDES

SMDR

Installing SMDR (Figure 5-4)

Station Message Detail Recording (SMDR) provides a record of the system's outside calls. Once set up in programming, SMDR automatically outputs from the RS-232 (serial) port on the CPU to a customer-provided printer, terminal or SMDR data collection device. When connecting SMDR, you can use one of the ready-made cables or make one of your own (see page 5-12).

You can also connect a PC to the CPU serial port to collect call history data.

● To connect an SMDR device:

1. Plug the DIN end of the 8-Pin DIN to Mod-8 Cable (P/N 80893) into the CPU serial port.
2. Plug one end of the DB9 to Mod-8 Adaptor (P/N 85980) into the cable.
3. Plug the other end of the adaptor into the DB9M COM connector on the back of your PC.

The Fixed Slot default communications parameters of the CPU serial port are 4800 8 N 1 (4800 baud, eight data bits, no parity and 1 stop bit).

The current U Slot default communications parameters of the CPU serial port are 19200 8 N 1 (19200 baud, eight data bits, no parity and 1 stop bit).

If you have a PC connected to collect history data, press Shift 1 to turn history on and off.

Programming SMDR

● 0301: CPU Baud Rate

Assign the baud rate for the RS-232-C port on the CPU. The options are 2 (1200), 3 (2400), 4 (4800), 5 (9600) and 6 (19200).

You can also press Ctrl Break on a PC connected to the CPU serial port to toggle through the available CPU baud rates.

● 0301: SMDR Port

Enter 1 to enable SMDR output from the CPU RS-232-C port.

● 0301: Print SMDR Header

Enter Y to have the beginning of the SMDR report include the column header data. Enter N to have the SMDR report only include the call data (without the header).

● 1001: Print SMDR

Enter Y to have the SMDR report include calls on the trunk. Enter N to have the SMDR report exclude calls on the trunk.

SMDR

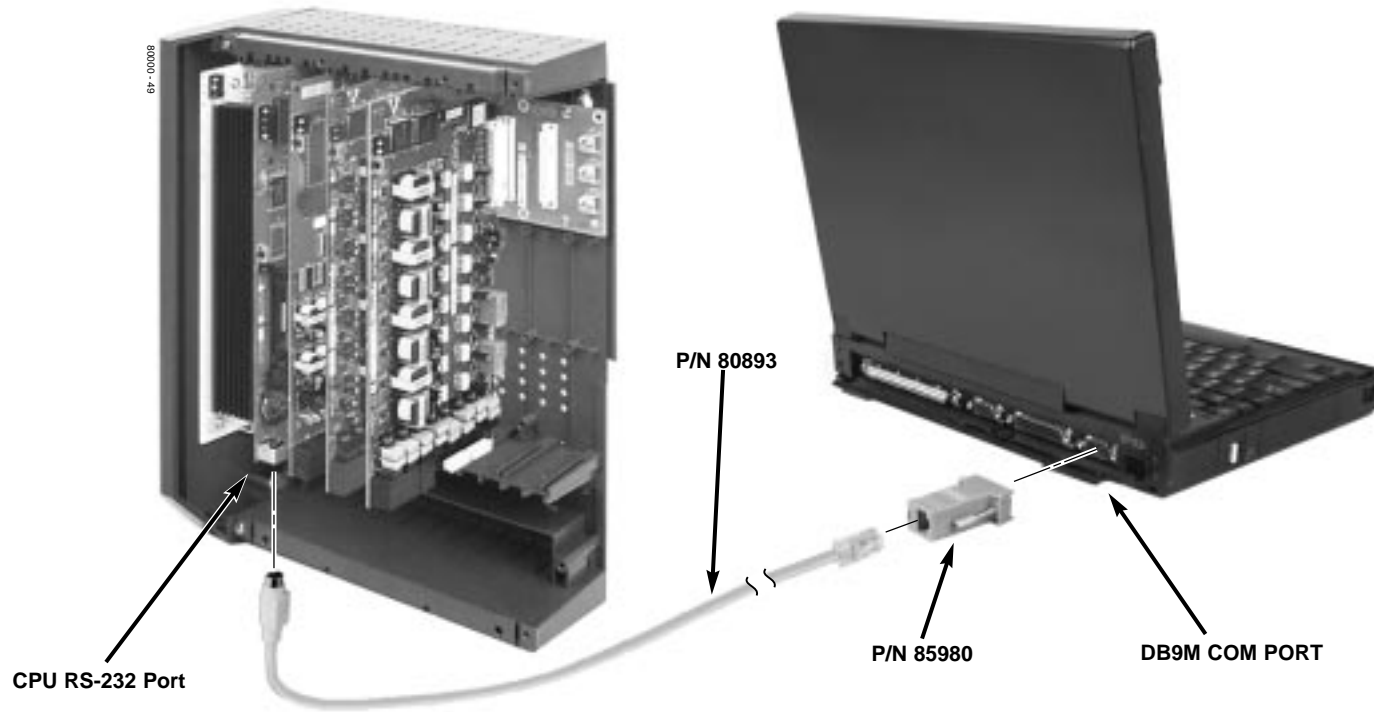

Figure 5-4 CONNECTING SMDR

MODEM INSTALLATION

Installing a Modem (Figure 5-5)

You can connect a modem to the CPU serial port to remotely collect history data and/or SMDR.

● **To connect a modem:**

1. Plug the DIN end of the 8-Pin DIN to Mod-8 Cable (P/N 80893) into the CPU serial port.
2. Plug one end of the DB25 to Mod-8 Adaptor (P/N 85981) into the cable.
3. Plug the other end of the adaptor into the DB25F connector on the back of your modem.
4. Following the instructions that came with your modem, connect a trunk and the modem's power supply.

● **To call from a PC at a remote site:**

The remote PC must have a modem connected. Also, the default communications parameters of the CPU serial port are 4800 8 N 1 (4800 baud, eight data bits, no parity and 1 stop bit).

1. Using commercially available communications software, dial the phone number of the trunk connected to the modem at the telephone system site.
2. To test history, type Shift 1 on the remote PC.

If history doesn't output correctly, press Ctrl Break on the remote PC to toggle through the available CPU baud rates.

MODEM INSTALLATION

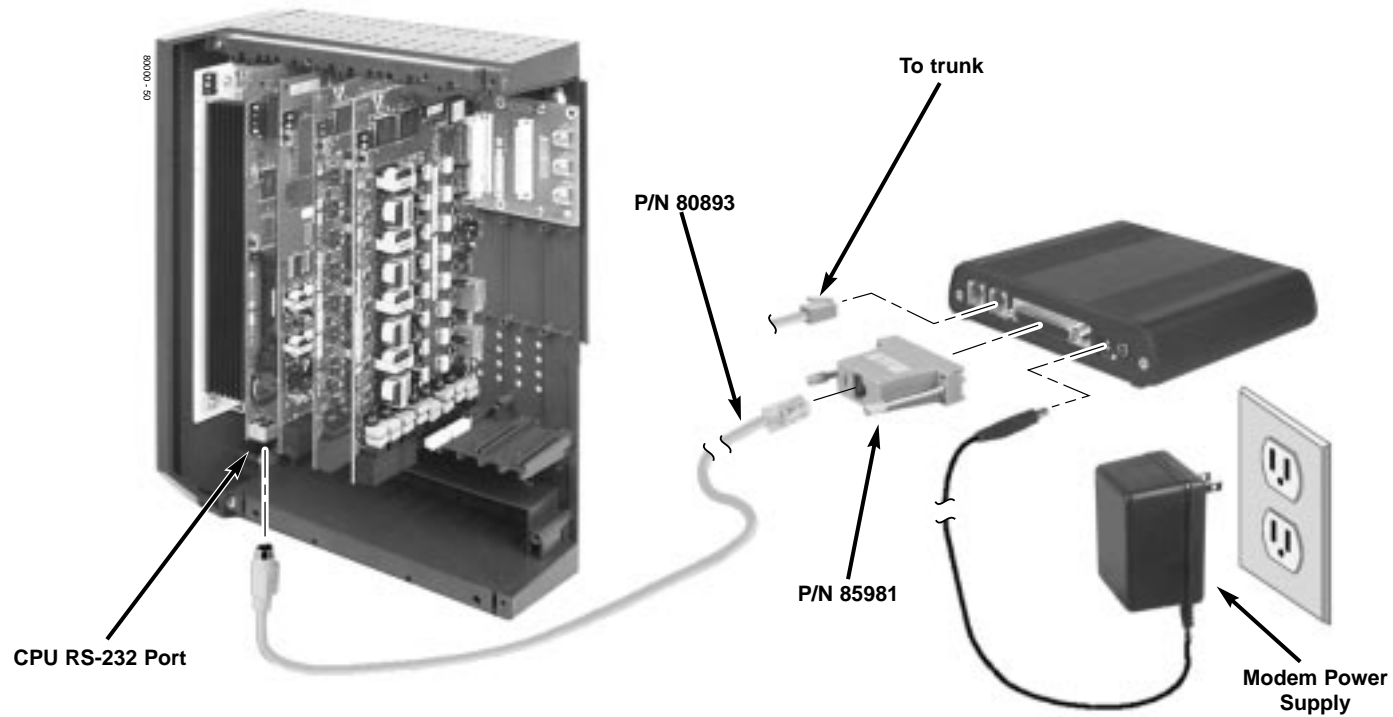

Figure 5-5 INSTALLING A MODEM

MAKING YOUR OWN DATA CABLES

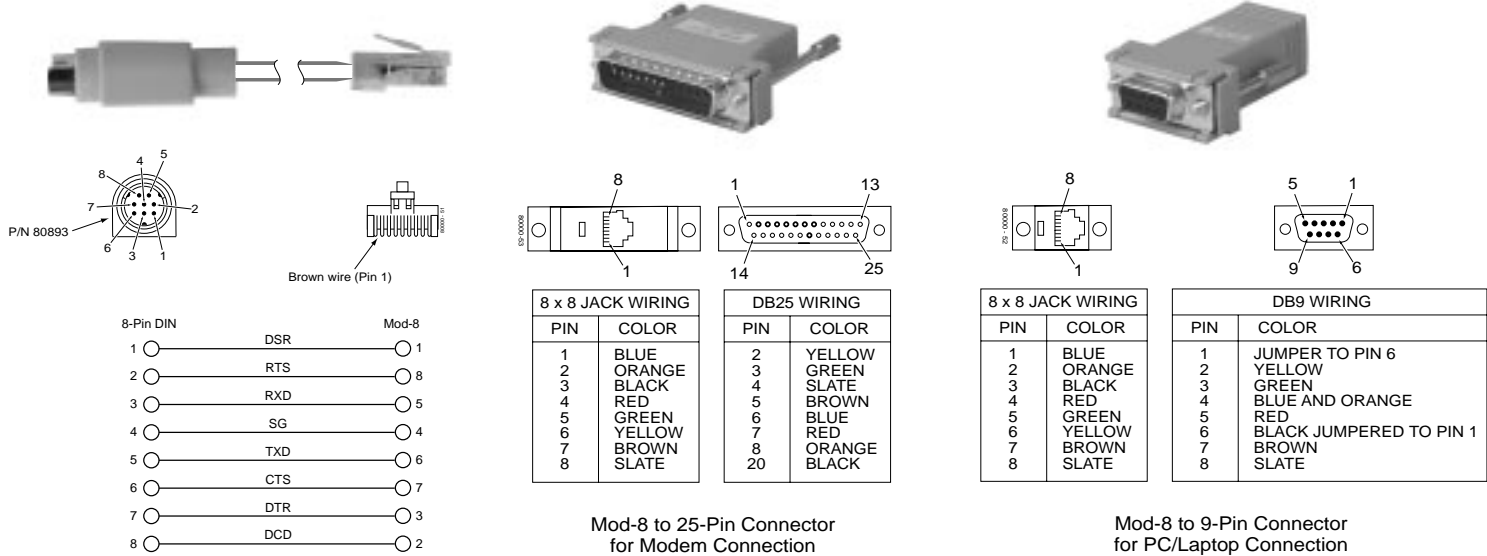

Figure 5-6 MAKING YOUR OWN DATA CABLES

Section 6, SPECIFICATIONS AND PARTS LIST

In this section . . .	Page
Specifications	6-2
Parts List	6-6

SPECIFICATIONS

System Capacities	
Cabinets:	1
Talk Timeslots (Intercom/line):	Non-blocking
Analog Trunks (CO/PBX lines):	4 Slot Fixed: 16
	4 Slot U: 24
	8 Slot U: 48
Digital and/or Analog Telephones:	4 Slot Fixed: 32
	4 Slot U: 40
	8 Slot U: 96
DSS Consoles:	1 max. per keyset, 4 max. per system
Power Failure Telephones:	2 per ATRU PCB
Door Boxes (digital):	1 per digital station port
External Paging Zones:	1 (1 per CPU)
Internal Paging Zones:	8 (7 and All Call)

System Capacities	
Conference Circuits	32 Conference circuits dynamically allocated, with 8 parties max. per Conference. Conference circuits provided on CPU.
8ATRU Analog Trunk PCB:	<i>Refer to System Configuration - U Slot on page 1-15 and System Configuration - Fixed Slot on page 1-18 for capacities.</i>
4ATRU Analog Trunk PCB:	
16DSTU Digital Station PCB:	
8ASTU Analog Station PCB:	
4ASTU Analog Station PCB:	
CPU Central Processing Unit:	1
REJ Recording Jack Units	1 max. per keyset

SPECIFICATIONS

Environmental Requirements

Meeting established environmental standards maximizes the life of the system. Refer to the Standard Practices Manual for further information. Be sure that the site is not:

1. In direct sunlight or in hot, cold or humid places.
2. In dusty areas or in areas where sulfuric gases are produced.
3. In places where shocks or vibrations are frequent or strong.
4. In places where water or other fluids comes in contact with the main equipment.
5. In areas near high-frequency machines or electric welders.
6. Near computers, telexes, microwaves, air conditioners, etc.
7. Near radio antennas (including shortwave).

Power Requirements

A dedicated 110 VAC 60 Hz circuit located within seven feet of the cabinet is required. You should install a separate dedicated outlet for each cabinet.

Environmental Specifications

Cabinets and Key Telephones

Temperature: 0-45°C (32-113°F)

Humidity: 10-95% (non-condensing)

Door Box

Temperature: 0-45°C (32-113°F)

Humidity: 10-95% (non-condensing)

Not intended for outdoor installation.

Electrical Specifications

The following specifications apply to each power supply installed.

Power Supply:	120 VAC \pm 10% @ 50-60 Hz
Output Power	91 Watts @ 100% full load
Input Current	1.50A @ 110 V
VA	165
Kwh	.165
BTU	563

Grounding Requirements: 12 AWG copper wire

SPECIFICATIONS

Mechanical Specifications

Equipment	Width	Depth	Height	Weight
4-Slot KSU	10 3/4"	5 7/8"	13 11/16"	4 lbs 5 oz
8-Slot KSU	19 1/2"	5 7/8"	13 11/16"	6 lbs 12 oz
Non-display Keypad	7 1/4"	9"	2 7/8"	1 lb 11 oz
Display Keypad	7 1/4"	9"	2 7/8"	1 lb 12 oz
Super Display Keypad	7 1/4"	9"	2 7/8"	1 lb 16 oz
DSS Console	7 7/8"	8 7/8"	2 3/4"	1 lb 6 oz
Door Box	4"	1 1/2"	5 3/16"	10 oz
2-OPX Module	9 3/8"	7 3/8"	1 1/4"	3 lbs

CPRU Relay Contacts

Contact Configuration: Normally open
 Maximum Load: 60 mA @ 30 VDC
 10 mA @ 90 VDC
 Maximum Initial Contact Resistance: 50 mOhms

External Paging

Output Impedance: 600 Ohm
 Output Level: 0 dBr at 1.0 KHz

SPECIFICATIONS

BGM/MOH Music Source Input	
Input Impedance:	10K Ohms
Input Level:	+18 dBr (+/- 2 dBr) t 1.0 KHz
Music input is located on the CPU PCB.	

FCC Registration Information				
Model:	DS2000			
Manufacturer:	NEC Infrontia, Inc.			
FCC Part 15 Registration:	Class A			
FCC Registration Number:	1ZDTHA27007-KF-E 1ZDTHA27044-MF-E			
Industry Canada Certificate (DOC) Number	854 9522 A			
Reg. Status	FIC	Mfrs. Port Identifier		Network Jacks
Original	02LS2	80010	REN 0.6B	RJ11C
		80011		RJ21X
Registered	OL13A	2OPX-A	SOC 9.0F	RJ21X
	OL13B	2OPX-A		RJ21X
	OL13C	2OPX-A		RJ21X

Cabling Requirements			
<ol style="list-style-type: none"> 1. Do not run station cable parallel with the AC source, telex or computer, etc. If the cables are near cable runs to those devices, use shielded cable with grounded shields or install the cable in conduit. 2. When cables must be run on the floor, use cable protectors. 3. Cable runs for key telephones, single line telephones, and Door Boxes must be a dedicated, isolated cable pair. 			
Device	Cable Type	Cable Run Length (ft)	Notes
Key Telephone,	2-wire 26 AWG	1300	
	2-wire 24 AWG	2000	
Single Line Telephone	2-wire 26 AWG	11,500	at constant 20 mA
		3150	at constant 35 mA
	2-wire 24 AWG	18,000	at constant 20 mA
		5050	at constant 35 mA
	2-wire 22 AWG	29,000	at constant 20 mA
		8000	at constant 35 mA
Door Box	2-wire 24 AWG	2000	
	2-wire 22 AWG	2000	
2-OPX	2-wire 24 AWG	1000	

PARTS LIST

Station Equipment	
Description	Part Number
34-Button Super Display Telephone	80673
34-Button Display Telephone	80663
22-Button Telephone	80570
22-Button Display Telephone	80573
24-Button DSS Console	80556
110-Button DSS Console	80555
Wall Mount Kit	80579
Analog Telephones (customer provided)	

Peripheral Station Equipment	
Description	Part Number
2-OPX Module	92177A
DS2000 Digital Door Box	80560

Common Equipment	
Description	Part Number
4-Slot KSU	80000
8-Slot KSU	80001
DS2000 Power Supply	80005
	80005A
Installation Cable	80892
Blank PC Card	85880
PC Card with system software preloaded (**,** denotes the system software level)	80051-V**.**
8-Pin DIN to Mod-8 Cable	80893
DB9 to Mod-8 Adaptor	85980
DB25 to Mod-8 Adaptor	85981
Spare KSU Hanger	80578
You must use an A version Power Supply in an 8 Slot Cabinet	

PARTS LIST

PCBs	
Description	Part Number
CPU Central Processing Unit	80025 80025A
16DSTU Digital Station PCB	80021 80021A
8ASTU 8 Port Analog Station PCB	80041 80041A
4ASTU 4 Port Analog Station PCB	80040 80040A
4ATRU 4 Port Analog Trunk PCB (loop start)	80010 80010A
8ATRU 8 Port Analog Trunk PCB (loop start)	80011 80011A
4 Circuit Caller ID Daughter Board Installs on 4ATRU PCB P/N 80010A	92012
8 Circuit Caller ID Daughter Board Installs on 8ATRU PCB P/N 80011A	80013

You must use all A version PCBs in an 8 Slot Cabinet

Replacement Parts	
Description	Part Number
Handset and Cord Assembly	80150
Noise Canceling Handset	80150NC
Handset Coil Cord - Black 9'	92297-9
Handset Coil Cord - Black 13'	92297-13
Handset Coil Cord - Black 25'	92297-25
Telephone Line Cord - Black 7"	82476-7
Telephone Line Cord - Black 14"	82476-14
34 Btn Super Display Tel Clear Plastic Cover	80600-S34
34 Btn Tel Clear Plastic Cover	80600-34
22 Btn Tel Clear Plastic Cover	80600-22
110-Button DSS Console Clear Plastic Cover	80600-DSS
24-Button DSS Console Clear Plastic Cover	80600-24DSS
Directory Tray	92602
Wall Mount Handset Clip Holder	80578
DS2000 RFI Bead Kit	88901

— For Your Notes —

NEC

NEC America, Inc., Corporate Networks Group
4 Forest Parkway, Shelton, CT 06484
Tel: 800-365-1928 Fax: 203-926-5458
cng.nec.com

Other Important Telephone Numbers

Sales:203-926-5450
Customer Service:203-926-5444
Customer Service FAX:203-926-5454
Technical Service:203-925-8801
Discontinued Product Service:900-990-2541
Technical Training:203-926-5430
Emergency Technical Service (After Hours)203-929-7920
(Excludes discontinued products)

Tl
6-
co

NEC

NEC America, Inc., Corporate Networks Group
4 Forest Parkway, Shelton, CT 06484
TEL: 203-926-5400 FAX: 203-929-0535
cng.nec.com