

MACKENZIE

DV-2000 MTS/LR

**Digital Autoload Storecaster &
Music Thru System with Local Record**



User's Manual
Version 1.0 Revised 2/23/2004
Doc 99-20-180 - \$25.00

MACKENZIE LABORATORIES, INC.
1163 Nicole Court
Glendora, CA 91740 USA

Tel: (909) 394-9007 Fax: (909) 394-9411
Email: info@macklabs.com
Web: www.macklabs.com

General Safety Instructions

Always follow these basic safety precautions when using the system:

1. Read carefully and understand all instructions.
2. Follow all warnings and instructions marked on the product.
3. DO NOT block or cover ventilation slots and openings.
4. DO NOT place the product in a closed enclosure or cabinet unless proper ventilation is provided.
5. Never spill liquid on the product or drop objects into the ventilation slots and openings. Doing so may result in serious damage to the components.
6. Repair or service must be performed by a factory authorized repair facility.
7. DO NOT staple or otherwise attach the power supply cord to building surface.
8. DO NOT use the product near or in wet or damp places, such as wet basements.
9. DO NOT use extension cord. Install within 6 feet of a grounded outlet receptacle.
10. DO NOT install during lightning storm.
11. Never touch un-insulated wires or terminals unless the unit is disconnected from both power and the rest of the phone system.
12. Use Caution when installing or modifying configuration switches or control lines.
13. Install in a protected location where no one can step on, or trip over, power and line cords.
14. The unit must be securely attached to a wall board, rack or table mounted.
15. Use correct power source. Use only the power pack supplied.



CAUTION:

If any wiring from the system leaves the premises, you must use proper electrical protectors.

Regulations:

FCC (Part 15) Radio Frequency Interference

The DV-2000 MTS/LR generates and uses radio frequency energy and if not installed and used in strict accordance with the manufacturer's instructions, may cause interference to radio and television reception. Unit complies with the limits for Class A devices in accordance with the specifications in Subpart J of Part 15 of the FCC Rules. This testing is designed to provide reasonable protection against such interference. However, there is no guarantee that interference will not occur in a particular installation. If this equipment does cause interference to radio or television reception, which can be determined by turning the unit off and on, the user is encouraged to try to correct the interference by one or more of the following measures:

-Reorient the radio or TV receiving antenna.

-Relocate the unit with respect to the radio or TV receiver or vice-versa.

-Plug the unit into a different outlet so that it and the radio or TV receiver are on different branch circuits

-If necessary, the user should consult the dealer or an experienced radio/television technician for additional suggestions.

Table of Contents

1.	OVERVIEW:	4
	1.1 Features and Benefits:	4
	1.2 General Specifications:	4
2.	Installation:	5
	2.1 Wall or Table Installation:	5
	2.2 Connecting the power pack.....	5
	2.3 Connection to Telephone equipment	5
	2.4 Connection to the PA equipment	5
3.	Operation:	5
	3.1 Message Downloading - Cassette:	6
	3.1.1. Message Download Mode 1 - Replace All	6
	3.1.2. Message Download Mode 2: Replace and Append	6
	3.2 Message Downloading - Local Record Handset:	7
	3.3 Automatic message playback	7
	3.4 Pushbutton descriptions.....	10
	3.5 LED (Light Emitting Diodes) descriptions	10
	3.6 Audio adjustments.....	11
	3.7 Slide Switch descriptions	11
	3.8 Connections	12
4.	Power failure recovery.....	12
5.	Troubleshooting guide.....	12
6.	Audio Tape Production Format:	13
7.	WARRANTY, SERVICE & RETURNS	14
	7.1 Warranty Coverage:	14
	7.2 What we ask you to do:.....	14
	7.3 What this warranty does not cover:.....	14

Shipping Container Contents

The following items should be found in the container of the DV-2000 MTS/LR - Autoload Storecaster & Music-Thru System with Local Record.

- DV-2000 MTS/LR System
- Power pack
- Audio cable
- Mounting hardware
- User's manual

Models:

Model #	Capacity	Bandwidth
DV-2008 MTS/LR PRO	8 minutes	6.8kHz
DV-2016 MTS/LR PRO	16 minutes	6.8kHz

Option:

Model #	Description
LR-HSET	Local Record handset and cable

1. OVERVIEW

The DV-2000 MTS/LR is a versatile Message-On-Hold and Storecasting System, now with Local Recording capability. The MTS/LR combines high quality audio playback, background music, selectable messages, remote control and recording features for use in even the most demanding applications.

1.1 Features and Benefits:

The DV-2000 MTS/LR is a highly reliable audio playback system specifically designed for Message-On-Hold and Storecasting applications. The system allows music and marketing messages while clients are waiting on-hold or in your retail location. This heightens awareness and minimizes frustration, thus increasing sales.

Message material may be loaded into the system via a ruggedized, electronically controlled cassette mechanism originally designed for automotive applications and providing years of reliable service. In addition, messages may be recorded live via the local record handset(optional) , for last minute changes or frequently updated material. Messages are digitized and stored in non-volatile FLASH memory that protects them from loss during power outage.

The DV-2000 MTS/LR supports up to 20 individual messages. Each message has an enable switch that allows the user to manually select which messages will be played for a particular application. The Background Music(BGM) input is for combining messages with an external music source such as CD or satellite. A built -in timer lets the user determine the time between message plays.

Multiple audio outputs(600ohm,8ohm) with level control, Aphex®, and high quality sampling allow the sound of the DV-2000 MTS/LR to be optimized for almost any phone or public address system, insuring that the message gets heard.

1.2 General Specifications:

Power:

12VDC

Audio Fidelity

6.8kHz(PRO)

60dB Signal to Noise

Handset Input:

RJ11 for local record handset(LR-HSET, supplied separately)

BGM Input:

RCA, mono, 10K ohm

Audio Outputs:

RCA, mono, 600 ohm

RCA, mono, 1W @ 8ohm

Manual Controls:

BGM level, BGM fade level, Aphex mix, Output volume, Eject,

Append/Replace, Speaker, Local Record, Delay, Play Mode

Switches:

Message enable/disable, Play mode, Delay min/sec

Package:

Painted steel chassis

Aphex®, Aphex Aural Exciter and AX are patented, registered trademarks of Aphex Systems, Ltd.

2. Installation:

This section provides complete instructions for mounting the DV-2000 MTS/LR. Before you install the DV-2000 MTS/LR system, make sure you have:

- A message or music on hold input on your phone system or line level input to your public address system.
- A non-switchable 110VAC electrical outlet near the location where the unit is to be installed.

2.1 Wall or Table Installation:

1. Locate a proper space on the telephone equipment board or wall. You can mount the DV-2000 MTS/LR unit in one of three positions: flat, side, or horizontal.
2. Position the unit on the board; mark the mounting hole locations.
3. Using the mounting screws provided, secure the DV-2000 MTS/LR system to the board or wall.
4. If table top mounting the DV-2000 MTS/LR, stick the enclosed rubber feet on the bottom of the unit.

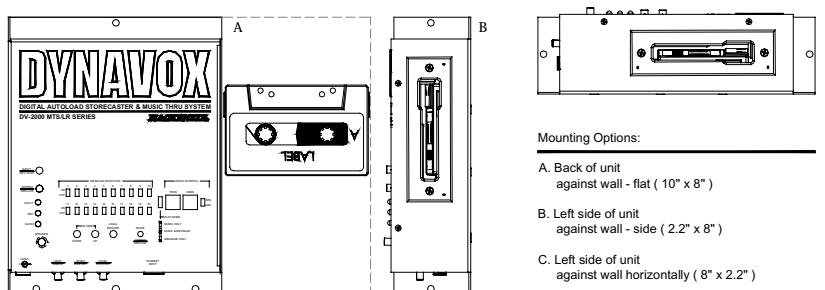

Figure 1 - Mounting

2.2 Connecting the power pack

1. Plug the power pack into a 120VAC power outlet which is not connected to a switch.
2. Plug the power plug into the DV-2000 MTS/LR system's power jack marked 12VDC.
3. There is no power switch on the DV-2000 MTS/LR system, so as soon as power is connected, the system will be active.

2.3 Connection to Telephone equipment

1. Connect one side of the supplied RCA cable to the telephone equipment's Message-On-Hold input. Connect the other side of this cable to the DV-2000 MTS/LR's LINE OUT. There are two audio outputs on the DV-2000 MTS/LR, LINE OUT (low level, +4dB into 600 ohms), and SPKR OUT (high level, 1W into 8 ohms). Use the LINE OUT first adjusting the audio output volume potentiometer to obtain the correct audio level. If this does not provide enough audio level, then switch to the SPKR OUT.

2.4 Connection to the PA equipment

1. Connect one side of the supplied RCA – RCA cable to the PA amplifier's line level input. Connect the other side of this cable to the DV-2000 MTS/LR's LINE OUT. There are two Audio outputs on the DV-2000 MTS/LR, LINE OUT(Low, +4dB into 600 ohms), and SPKR OUT(High, 1W into 8 ohms). Use the LINE OUT first adjusting the audio output volume potentiometer to obtain the correct audio level. If this does not provide enough audio level, then switch to the SPKR OUT.

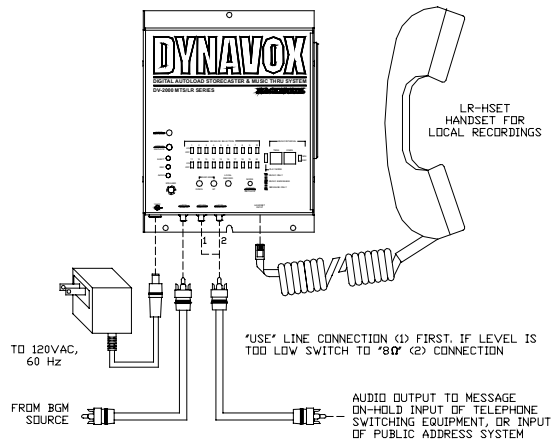

Figure 2 - Connection

3. Operation:

3.1 Message Downloading - Cassette:

When you receive the new DV-2000 MTS/LR Storecasting system, its memory will be blank. To load new messages into the DV-2000 MTS/LR's memory, simply insert a pre-recorded, and properly formatted (Section 6), cassette tape into the DV-2000 MTS/LR unit. Make sure to insert the tape with the side which audio is on facing toward the top of the machine.

When a new tape is inserted, the DV-2000 MTS/LR will automatically rewind the cassette to the beginning and start playing it. The DV-2000 MTS/LR will record the audio program(s), ignoring the silence segments on the cassette. When the Audio program on the tape starts, the red Record light will come on signifying that Audio is being recorded. At the end of the Audio program, when the DV-2000 MTS/LR detects 6 seconds of silence, the Record LED will go out. The system will keep playing the tape while it "looks" for another message on the tape. If another message exists, the red Record light will go on signifying that another message is being recorded. When the last message on the tape is recorded, signified by 15 seconds of silence, the system will automatically rewind the cassette tape.

The DV-2000 MTS/LR system offers two Message Download Modes; Replace All and Replace and Append. See below for details.

3.1.1 Message Download Mode 1 - Replace All (Replace/Append LED: OFF)

When this mode is used, the system will erase all the messages in memory as soon as the tape is inserted. The system will begin recording the messages from the cassette tape into memory starting from message #1 and continuing through the last message on the tape. Use this mode any time all of the messages on the DV-2000 MTS/LR system need to be updated.

Important: Once a tape is inserted into the DV-2000 MTS/LR system, in this mode, all of the messages in memory will be deleted immediately. Even if the tape is then ejected prior to recording any audio, the DV-2000 MTS/LR's memory will be empty.

3.1.2. Message Download Mode 2: Replace and Append (Replace/Append LED: ON)

This mode allows the user to add or replace any number of messages on the system. Activate this mode by pressing the Replace/Append button until the Replace/Append LED lights. Turn ON the message selection switches of the messages to be overwritten. Make sure to turn OFF the message selection switches of the messages you want saved. Insert the tape with the new messages on it and the system will rewind the cassette and start playing it. The first message on the tape will overwrite the first active message, signified by its message selection switch being ON. The second message will replace the second active message, and so on.

If there are more messages on the cassette tape than there are messages on the machine set up to be overwritten, the DV-2000 MTS/LR will append the extra messages until there are twenty messages recorded on the system, or until the last message on the cassette tape is reached.

Example: The DV-2000 MTS/LR system has ten messages currently recorded on the system. To replace message 3 and 7 with new messages and add three more messages to the system follow the steps below:

1. Activate the Replace/Append mode.
2. Enable message selection switches 3 and 7.
3. Disable all other message selection switches.
4. Insert the cassette tape which has the five new messages on it.
5. The system will record the first message on the tape into message location #3.
6. The system will record the second message on the tape into message location #7.
7. The system will then record the last three messages of the cassette tape into locations #11, 12, and 13 on the DV-2000 MTS/LR, respectively.

It is not necessary to enable a message location to Append messages to memory. If the user wants to simply append messages to the system, activate the Replace/Append mode and disable all of the message selection switches. Insert the cassette tape with the new messages into the DV-2000 MTS/LR and it will record the messages on the tape to any empty message locations on the machine.

The Audio being recorded will be output through the 8 ohm and line outputs during the recording process. This audio may also be monitored locally by depressing the "Speaker" button.

3.2 Message Downloading - Local Record Handset:

You may also create messages for the DV-2000 MTS/LR by recording them directly to the unit using the optional LR-HSET handset. This feature allows you to make a custom recording to any of the 20 message locations on the unit. These messages may be updated at any time for maximum flexibility.

1. Plug the LR-HSET(sold separately) into the Local Record Input.
2. Press the Local Record pushbutton to initiate the record sequence, Record LED(RED) will blink.
3. Toggle the desired message location switch two(2) times to begin recording.*
4. The Record LED should now be illuminated, record your message into the handset.
5. Press the Record(RED) button to stop recording.
6. A preview of the message will automatically be played after the recording has been stopped.

*NOTE: Local recordings may be made to message locations that are either enabled or disabled. If disabled, toggle the switch up then down to begin recording. If the message location is enabled, toggle the switch down then up to begin recording. Always leave the switch up, or enabled, if you want it to playback.

3.3 Automatic message playback

After messages have been recorded into memory, the DV-2000 MTS/LR will automatically begin playing them through the audio outputs. There is no control, or user input, required to initiate the playback. The green, Audio LED will light whenever the system is playing messages.

All enabled messages will be played back sequentially. If an enable switch is active, but has no associated message recorded into that position, the position will be skipped.

The messages in memory are automatically played back sequentially with a user programmed delay time inserted between them(see section 3.7 for delay configuration information).

In between pre-recorded message plays, the DV-2000 MTS/LR will output the background music, BGM, audio to the audio output. The DV-2000 MTS/LR will gently fade the BGM audio up after a pre-recorded message is played, and it will gently fade the BGM audio down just prior to a pre-recorded message play.

3.4 Pushbutton descriptions

Eject / Rec Stop pushbutton – Red, momentary

Allows the user to stop the recording process, in several ways, and/or eject the tape.

- When the system is not recording, the button functions as an Eject button.
- When the DV-2000 MTS/LR is recording audio, (whenever the Record LED is on) pressing this button momentarily will stop the recording and save the Audio which was just recorded. The system will rewind the tape, but not eject it.
- If this button is pressed and held for two seconds while the DV-2000 MTS/LR is recording, the message just recorded will be deleted, and the tape will be ejected without being rewound.
- If the button is pressed momentarily while the DV-2000 MTS/LR is recording audio, and then pressed momentarily again, the system will stop the recording process, save the Audio just recorded, and eject the cassette tape without rewinding it.

Append / Replace pushbutton – Black, momentary

Pressing this button toggles the Replace/Append mode. The status of the Append and Replace mode is signified by the Replace/Append LED. When this LED is on, the system is in Replace/Append mode. This setting is not saved when power is removed, and reapplied to the unit.

Operation of the unit in Replace/Append mode is described in the Message Download section(3.1).

Speaker pushbutton – Black, locking

A monitor speaker, on the front side of the unit, allows the local user to hear the Audio being output by the DV-2000 MTS/LR. Pressing this button will activate the monitor speaker. Releasing the button will deactivate the monitor speaker.

The volume of the monitor speaker is determined by the volume setting of the Audio output. If the phone system requires a particularly low level from the DV-2000 MTS/LR, the volume of the monitor speaker will also be low.

Note: Do not adjust the Audio output level adjustment in order to hear the monitor speaker level better. Doing this will adjust the level of the Audio output which may not be acceptable.

Local Record pushbutton – Green, momentary

Pressing this initiates local recording.

3.5 LED (Light Emitting Diodes) descriptions

Eject LED, Yellow

This LED will light whenever the tape is ejected, i.e. no tape in the system. When a tape is inserted, and loaded, i.e. tape is completely inside the machine, this LED will go out.

Record LED, Red

This LED will light when the DV-2000 MTS/LR starts recording an Audio program, and will go out when the recording process stops. This LED also blinks while the system is in local record setup mode.

The Record LED will blink one time when the DV-2000 MTS/LR is powered on, indicating that the memory operational.

M-O-H LED, Green

This LED will light whenever the DV-2000 MTS/LR is in automatic playback mode and playing messages, or outputting the BGM audio.

Mode - Append / Replace, Red

This LED indicates the message download mode. When this LED is OFF, the system is in Replace All mode. When this LED is ON, the system is in Replace and Append mode. This setting is not saved when power is removed, and reapplied to the unit. Operation of the unit in Replace/Append mode is described in the Message Download section.

3.6 Audio adjustments

There are three potentiometers and two pushbuttons on the DV-2000 MTS/LR system allowing the user to tailor the BGM level, the audio output level and high frequency response. Refer to the Quikey for location of each control.

Audio level

The level of the both 600 and 8 ohm Audio outputs are simultaneously adjusted using the Audio level adjustment pot. Turning this potentiometer counter clockwise will lower the Audio level. Turning this potentiometer clockwise will raise the Audio level.

Aphex®

A special, psycho-acoustical processing extends the high frequency response of the DV-2000 MTS/LR. Turning this potentiometer counter clockwise attenuates the high frequencies while turning it clockwise amplifies the high frequencies.

BGM In

This sets the overall level of the background music being fed into the DV-2000 MTS/LR. Turning this potentiometer counter clockwise will lower the BGM level. Turning this potentiometer clockwise will raise the BGM level.

BGM Fade

Two pushbuttons are provided on the top cover allowing the user to set the amount of "ducking" to be applied to the BGM audio when a pre-recorded message is played by the system. The BGM audio is mixed with the pre-recorded message audio, and this setting governs the amount of BGM audio being mixed. "Ducking" is the amount which the BGM audio level is attenuated, or lowered.

BGM Fade Down pushbutton – Black, momentary

Pressing this button will increase the ducking amount, or, in other words, lower the BGM audio being mixed in with the audio output when a pre-recorded message is played. Pressing the button one time will attenuate the BGM audio approximately 1dB. If the button is pressed and held, the BGM level will be lowered approximately 8dB per second.

BGM Fade Up pushbutton – Black, momentary

Pressing this button will decrease the ducking amount, or, in other words, increase the amount of BGM audio being mixed in with the audio output when a pre-recorded message is played. Pressing the button one time will raise the BGM audio approximately 1dB. If the button is pressed and held, the BGM level will be raised approximately 8dB per second.

3.7 Slide Switch descriptions

Several slide switches are provided on the top cover of the DV-2000 MTS/LR. These switches control the functions described below:

Message Selection Switches

The DV-2000 MTS/LR system can record and play up to 20 messages. Each message has a message selection switch associated with it. These switches allow the user to enable or disable messages to be played, or recorded. The system will recognize changes of the message selection switches during normal operation.

When a message selection is in the "ON" position, the message is enabled. When the DV-2000 MTS/LR is in play mode, it looks at the switch for all recorded messages. If the message is enabled, the system will play the message. When a message selection switch is in the "OFF" position, the message is disabled. If the switch is disabled, the system will skip the message.

When the DV-2000 MTS/LR is in record mode with Append/Replace mode active, the system will overwrite any messages whose message selection switch is enabled, while protecting the messages whose message selection switch is disabled. All message

selection switches are ignored when the system is recording and the Append/Replace mode is not active.

Play Mode

The DV-2000 MTS/LR system has three play modes, Music Only, Message Only, and Music and Message. A three position slide switch sets the mode of the system.

Music Only – No pre-recorded messages are played when the system is in this mode. The system will simply route the BGM audio directly to the output.

Message Only – Pre-recorded messages will be played sequentially based on the Music Interval setting. The BGM audio will be muted, however. No audio will be present on the audio output connector between pre-recorded message plays.

Music and Message (Default) – This mode allows Pre-recorded messages to be played sequentially based on the Music Interval setting. When a message is playing, the BGM audio will be mixed in with the pre-recorded audio. Between pre-recorded message plays, the BGM Audio will be routed directly to the audio output.

Music Interval

Two Rotary switches and a slide switch make up the Music Interval setting. The two rotary switches allow for a setting from 00 to 99. The left rotary switch represents the “tens” position, while the right rotary switch represents the “ones” position. The slide switch to the right of the rotary switches sets whether the 00 to 99 setting is in minutes or seconds.

These switches are read by the system during operation, so changing the setting can be performed while the unit is playing messages.

3.8 Connections

12VDC, 2.5mm Barrel connector

The system is powered by 12VDC. Use only the AC-DC power adapter supplied by the manufacturer to guarantee proper operation.

BGM IN, RCA connector

A 10K ohm, transformer isolated, audio input. When installing the DV-2000 MTS/LR system, connect this input to the output of the background music source.

LINE OUT, RCA connector

A 600 ohm, transformer isolated, Audio output. When installing the DV-2000 MTS/LR system, connect this output to the phone system, or PA system, first.

SPKR OUT, RCA connector

An amplified, 1 watt into 8 ohm, Audio output. Use this Audio output if the Audio from the Line output can't drive the on-hold circuit, or PA amplifier, to a high enough level.

Local Record, RJ11 connector

Local record input for connecting an optional handset(LR-HSET).

4. Power failure recovery

The DV-2000 MTS/LR uses FLASH memory which is not dependent upon power or battery backup to retain its memory. This eliminates problems associated with brown outs or unexpected power losses. When power is returned, the system will immediately start the operation it was in prior to power being removed.

5. Troubleshooting guide

Before contacting the factory, please review the following answers to some common problems.

No LEDs are active on the DV-2000 MTS/LR.

- When a tape is inserted, and before audio is detected by the system, all LEDs will be off.
- Verify that the AC-DC power adapter is plugged into non-switched AC power outlet.
- Verify that the power connector is plugged completely into the jack on the DV-2000 MTS/LR.

The system will not mechanically load the tape into the system

- Push the cassette tape completely into the DV-2000 MTS/LR.
- Verify that the AC-DC power adapter is plugged into non-switched AC power outlet.
- Verify that the power connector is plugged completely into the jack on the DV-2000 MTS/LR.

The system ejects the tape immediately after it is loaded.

- If in Append & Replace mode and the memory is full.
- If in Append & Replace mode and all of the messages are used.
- If it is an endless loop tape.

The Record LED never comes on after the cassette tape is loaded into the system

- Verify that the tape was inserted right side up.
- If the tape is blank, the Record LED will never come on.
- Verify that the nominal level of the Audio recorded on the tape is over -20dB .

After recording the tape, the tape ejected, and the system is not playing a message.

- Pressing, and holding the edit/eject button while recording will eject the tape immediately.
- Verify that the tape was inserted right side up.
- If there is no audio on the tape, it will eject automatically when it reaches the end of the tape.

Can't hear anything from the audio output

- If both Record and M-O-H LEDs are off, there is no audio being output by the system.
- Verify that the RCA to RCA connector is securely attached to the DV-2000 MTS/LR and the phone system.
- Turn the output level adjustment clockwise to increase the Audio output level.
- Use the 8 ohm output instead of the line level output.

Can't hear anything through the monitor speaker

- If both Record and M-O-H are off, there are no recorded messages on the system.
- Press the Speaker button so that it locks in the depressed position.
- If the audio output is adjusted low, the level from the monitor speaker will also be low.

The system didn't record all the messages on the tape

- If there is noise in the silence portions separating the messages on the cassette tape, multiple messages can get grouped into a single message location on the system.
- If in Append/Replace mode, the tape has more messages on it than there are locations enabled or available on the system.

6. Audio Tape Production Format:

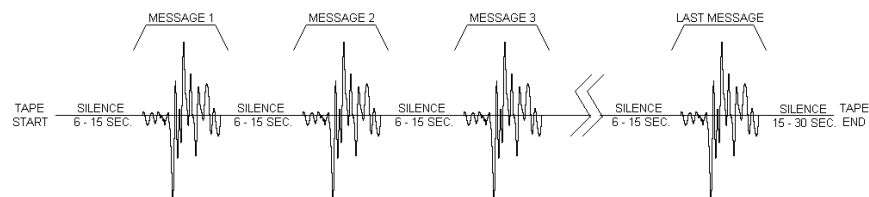

- Messages must be recorded on the left channel or track A.
- The length of individual messages do not have to be the same, but the total length of all messages should not exceed the total memory capacity of the unit.
- The silence portion between messages is not included in the maximum recording time.
- The audio should be set to a nominal level of $0\text{VU} = -4\text{dBm}$.
- For best results, the audio should be filtered to cutoff any frequencies higher than 6.8kHz for the PRO version.
- The dynamic range of the production should be held low so as to allow the production to be recorded at the highest possible level without exceeding $+5\text{VU} = +1\text{dBm}$. The system requires 1 seconds of constant audio at a level greater than -20dBm for the system to acknowledge the production and start recording. This is required so that the system can discriminate between tape noise and message material.

7. WARRANTY, SERVICE & RETURNS

The industrial grade housing and quality construction of the Mackenzie DV-2000 MTS/LR virtually eliminates the need for service or maintenance. There are no user-serviceable components within the Mackenzie DV-2000 MTS/LR. Refer all servicing to the factory.

7.1 Warranty Coverage:

The Mackenzie DV-2000 MTS/LR is tested and checked before shipment and are guaranteed against defective material or workmanship for a period of three (3) year from the date of purchase. Should trouble ever develop, contact the Factory directly by telephone or in writing. If it is determined that the equipment requires Factory service, return it to the Factory. If our inspection shows that the trouble was caused by defective material or workmanship, we will repair or replace the equipment without charge and return prepaid. Repairs made necessary by abuse, improper use, unauthorized service or maintenance, and/or improper installation, as well as out of warranty repairs, will be charged at our regular repair prices in effect at the time. The obligation under this warranty shall be limited to the replacement, repair or refund of any such defective device within the warranty period.

This warranty is in lieu of and excludes all other warranties, expressed or implied, and in no event shall MACKENZIE be responsible for damage to other equipment or property, for any anticipated profits, consequential damages, loss of item, or other operation or use of this product, and MACKENZIE'S maximum liability shall not ever be greater than the price paid for the equipment. This warranty gives you specific legal right. Your rights may vary from state to state. Inquiries regarding use, repair and service should be made to:

MACKENZIE LABORATORIES, INC.
1163 Nicole Court, Glendora, CA 91740 USA
Telephone: (909) 394-9007
FAX No: (909) 394-9411
Email: info@macklabs.com
WWW: www.macklabs.com

7.2 What we ask you to do:

To get warranty service for your DV-2000 MTS/LR system, you must provide proof of the date of original purchase. In the event you need to ship your DV-2000 MTS/LR system to the factory for service, call us for a return authorization number. When you ship your DV-2000 MTS/LR system, you must prepay all shipping cost. We suggest that you retain your original packing material in the event that you need to ship your DV-2000 MTS/LR system. When sending your DV-2000 MTS/LR system to the factory, include your name, address, phone number, proof of date of purchase, and a description of the operating problem. After repairing or replacing your DV-2000 MTS/LR system, we will ship it to your return address at no cost to you within the USA. Repair or replacement of your DV-2000 MTS/LR system at our factory is your exclusive remedy.

7.3 What this warranty does not cover:

This warranty does not cover defects resulting from accidents, damage while in transit to factory, alterations, unauthorized repairs, failure to follow instructions, misuse, fire, flood, and acts of God.

Return Address

MACKENZIE LABORATORIES, INC.
1163 Nicole Court
Glendora, CA 91740 USA

OTHER MACKENZIE PRODUCT LINES

Digital Message Repeaters - Mackenzie's line of Digital Message repeaters are the ideal audio announcement solutions for Public Address, Amusement, Entertainment, Museum and Exhibit applications. Self contained solid state systems offer unparalleled reliability. A variety of channel, connection, bandwidth and memory configurations are available.

Controls and Peripherals - Many applications require additional equipment to optimize the performance of Mackenzie products. This area focuses on items developed or sourced for their compatibility, ease of use and value. Included are, input/output controllers, speakers, amplifiers, motion sensors and pushbuttons among others.

Transit - Mackenzie is making a difference in transit applications with innovative solutions for ADA compliance and Passenger Information Systems. These products address a variety of audio and text messaging requirements and support both in-vehicle and wayside installations.

Overhead Page Management - Mackenzie's OPM and FE series of Digital Page Stacker/Repeater and Feedback Eliminators offer advanced features for the most difficult paging and intercom applications. A unique design makes feedback virtually impossible by recording then repeating pages which opens the loop between the input microphone and speakers. Various models are available to support simple repetition, multiple page stacking and multiple input channels.

**Model DV-2000 MTS/LR & DV-2000 MTS/LR PRO
DIGITAL AUTOLOAD STORECASTER & MUSIC THRU SYSTEM**

1 MESSAGE SELECTION

Enable and disable messages to be played or recorded.

EJECT / RECORD STOP PUSH-BUTTON:

2 This ejects the tape when the system is playing a message. If pressed during the recording process the recording will be stopped.

APPEND / REPLACE PUSH-BUTTON:

3 Toggles the Append / Replace mode as displayed on the associated LED.

NO TAPE LED:

4 Yellow light ON indicates there is no cassette inserted. Yellow light OFF indicates the cassette is in place.

RECORD LED:

5 Used to determine tape loading mode. Red light ON, indicates message (s) is being loaded into memory.

PLAYING LED:

6 This green LED is ON when the system is playing a Pre-Recorded message.

SPEAKER PUSH-BUTTON:

7 Turns local Monitor ON/OFF.

POWER:

8 Insert supplied power adapter.

BGM LEVEL:

9 Adjusts level of external music source.

BGM INPUT:

10 Connect to external source of music.

**The Mackenzie Dynavox
DV-2000 MTS/LR & MTS/LR PRO Quikey
V 1.0 Feb. 24, 2004
Mackenzie Laboratories, Inc.
1163 Nicole CT, Glendora, CA 91740 USA
TEL (909) 394-9007 FAX (909)394-9411
www.macklabs.com**

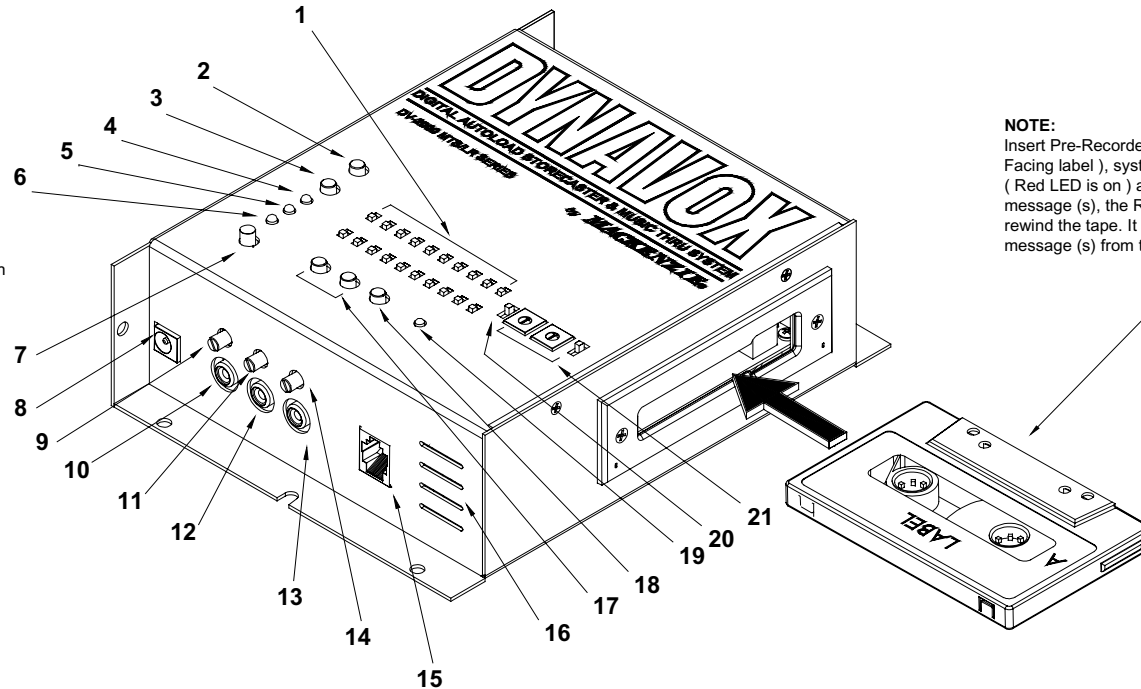

NOTE:

Insert Pre-Recorded tape Cassette as shown (Tape up, Facing label), system will rewind tape then start loading (Red LED is on) at the end of downloading the message (s), the Red LED will turn off, system will rewind the tape. It will automatically start playing the message (s) from the digital audio memory Enabled.

11 APHEX MIX:

Adjusts the amount of high frequency enhancement necessary to deliver the best overall system performance.

12 AUDIO OUTPUT (LINE):

Audio output level of up to +4dB into 600 Ω, this is a standard level for most applications.

13 AUDIO OUTPUT (POWER):

Audio output level of up to 1W into 8 ohm. Use this output if more drive is needed to reach a more comfortable listening level.

14 LEVEL:

Adjusts the volume to the line level or power audio outputs.

15 LOCAL RECORD INPUT:

Use with LR-HSET (optional) hand set for local recording.

16 MONITOR SPEAKER:

Allows user to preview message recording and play back.

17 BGM FADE UP / DOWN PUSH-BUTTON:

Adjusts the Amount the BGM input is ducked when a message is played.

18 LOCAL RECORD PUSH BUTTON:

Press this button to initiate local record function

19 REPLACE / APPEND MODE LED:

Indicates if system is in Standard mode (OFF) or Replace & Append mode (ON).

20 PLAY MODE SWITCH:

UP = music only.
MID. = music & message.
DOWN = message only.

21 MUSIC INTERVAL

MINUTE/SECOND SWITCH: Select between minute or second mode.
TENS AND ONES ROTARY: To set musical interval between message playing. Set the rotary switches to the desired time between 00 and 99.